

A Model for the Epidemiology of Tuberculosis

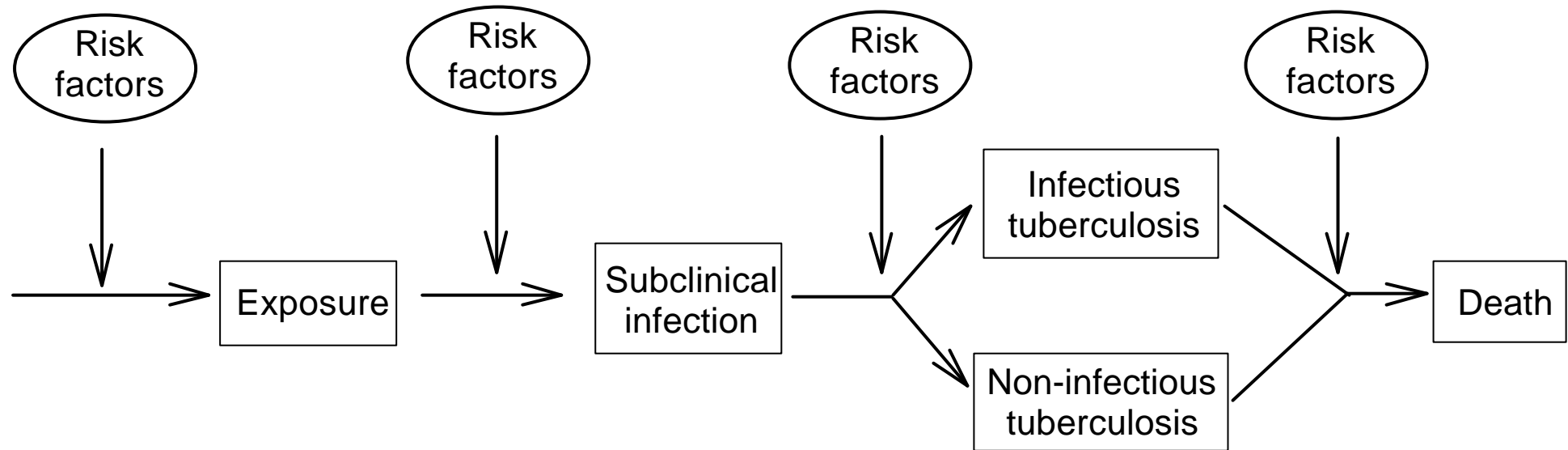

Change in the Median Age of Tuberculosis Patients, Finland, Among Males and Females, 1954 - 1995

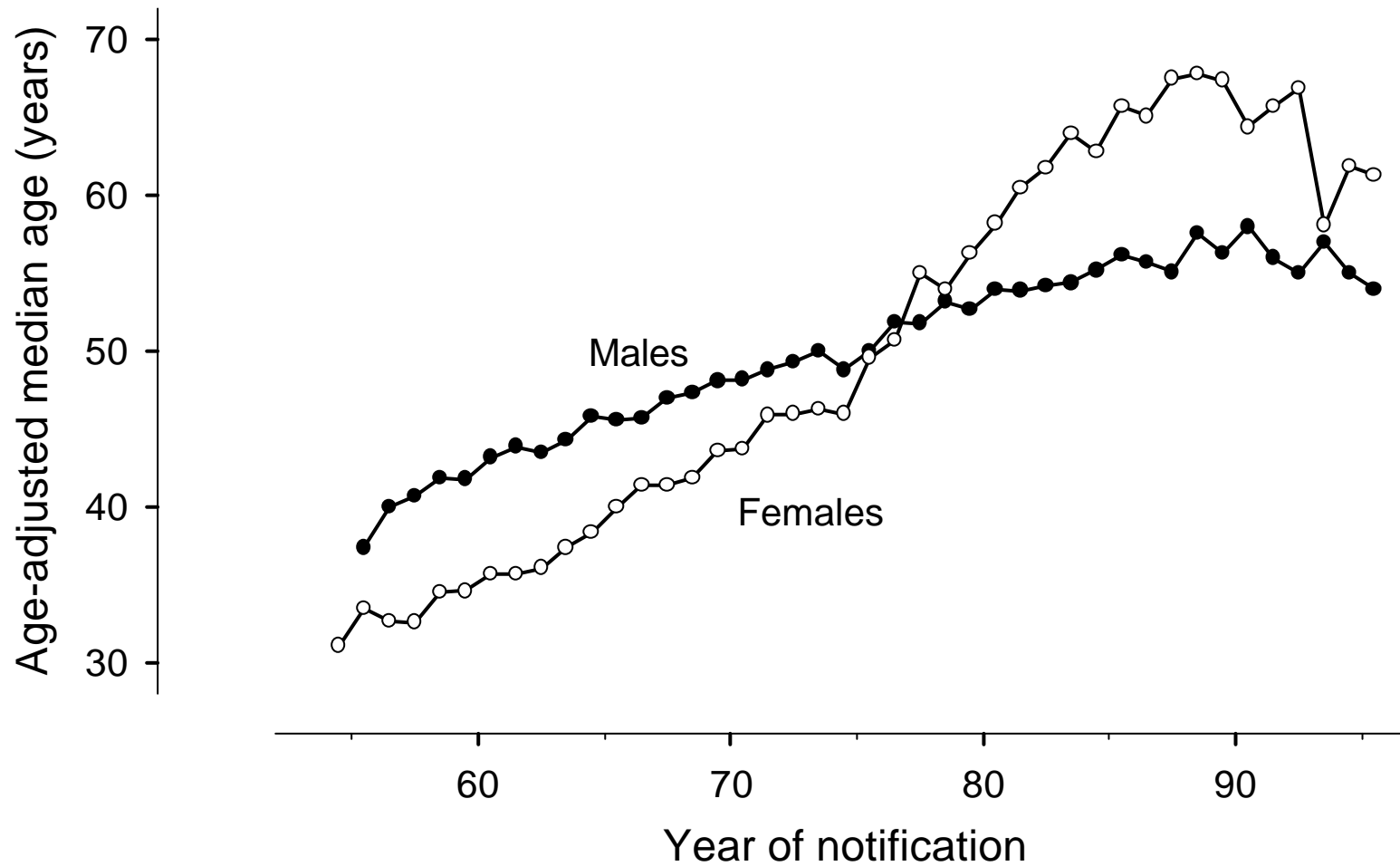

Settling of Water Droplets in Saturated Air

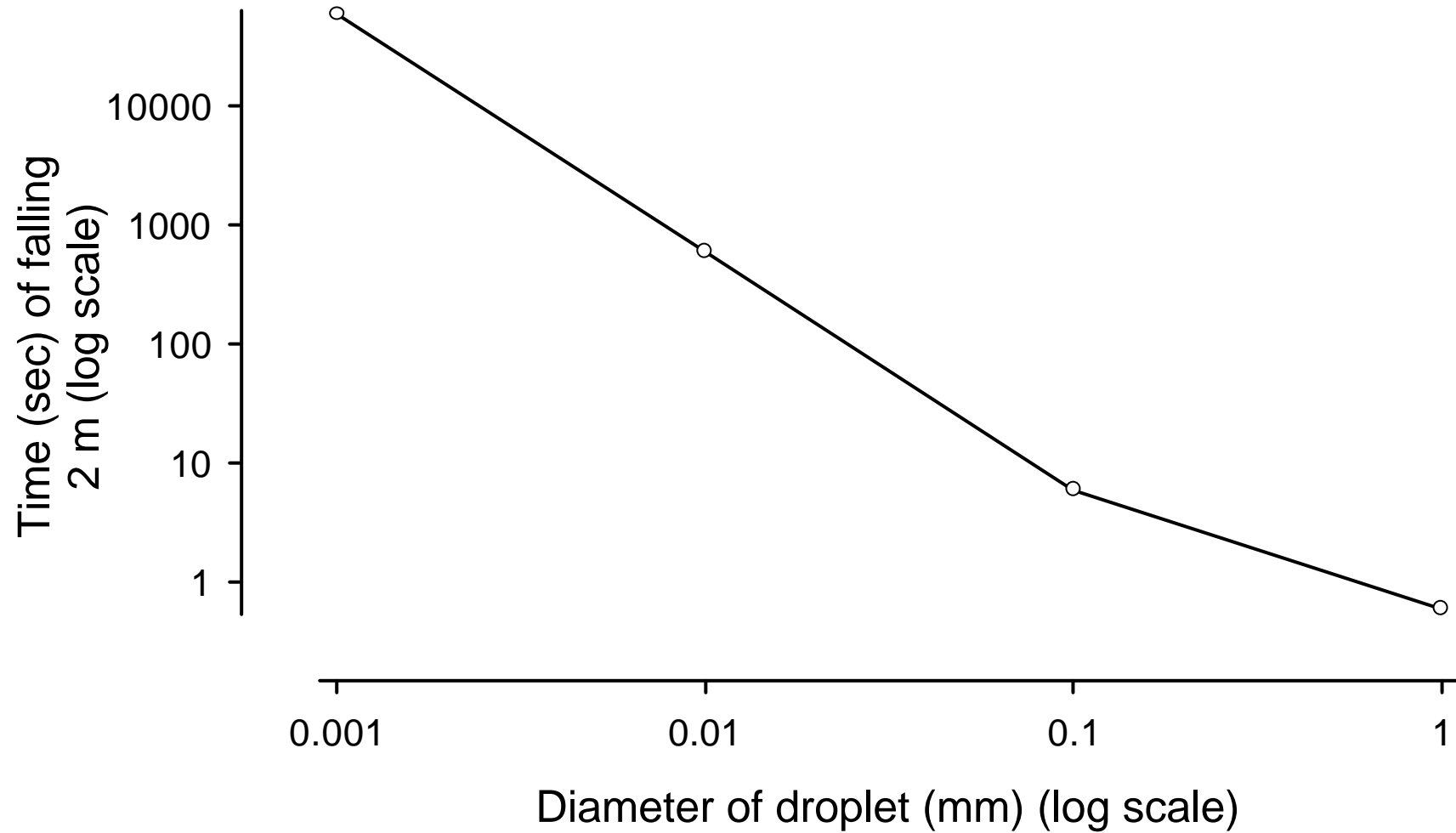

Wells WF. Am J Hyg 1934;20:611-8

Evaporation Time of Water in Unsaturated Air at 18⁰ C

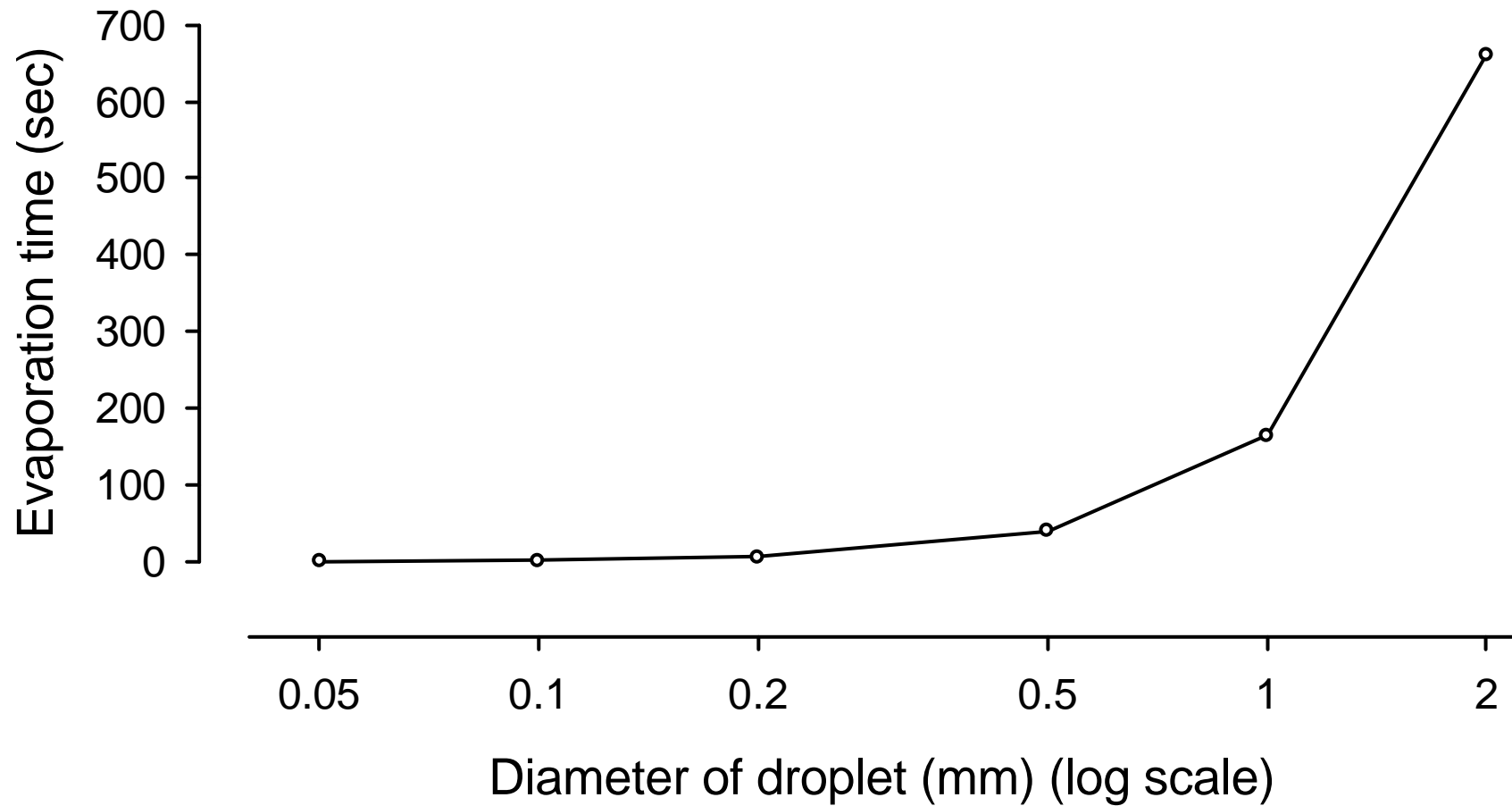

Wells WF. Am J Hyg 1934;20:611-8

Falling and Evaporation Times of Droplets of Varying Diameters

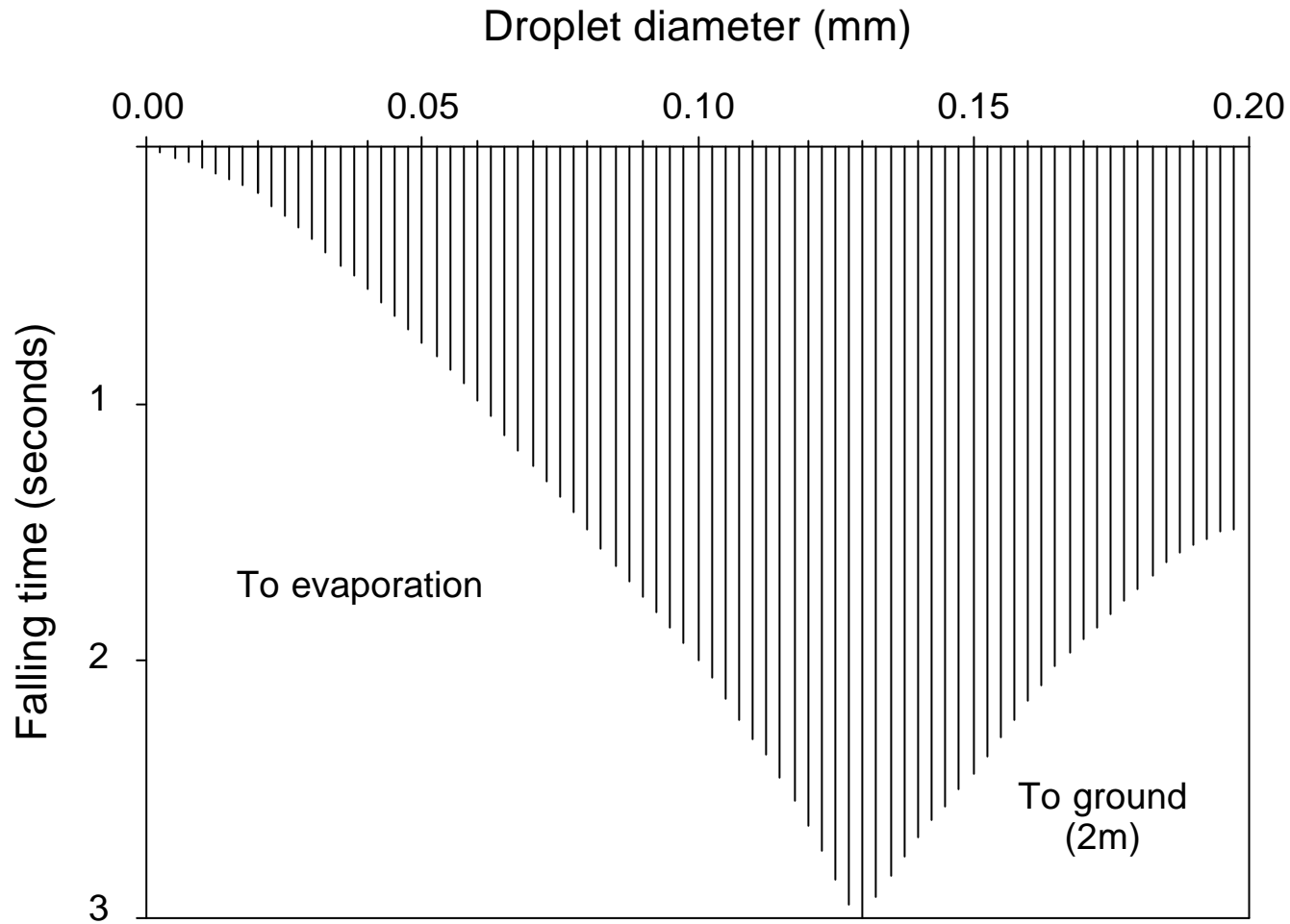

Figures accompanying monograph: Figure 7

Hans L. Rieder. Epidemiologic basis of tuberculosis control. Paris: International Union Against Tuberculosis and Lung Disease, 1999

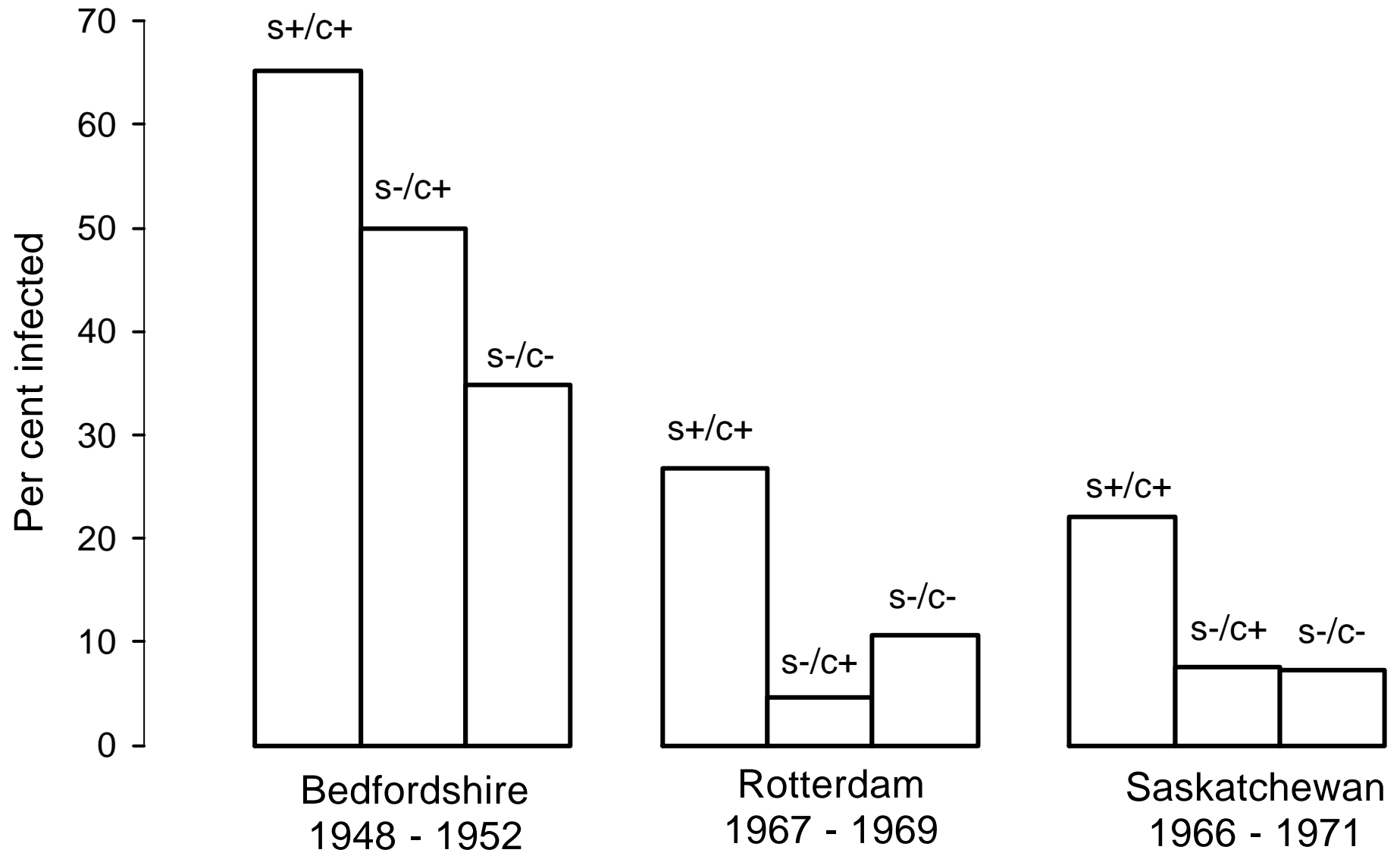

Tuberculous Infection Among Children by Type of Contact and Bacteriologic Status of Index Case, British Columbia and Saskatchewan, 1966 - 1971

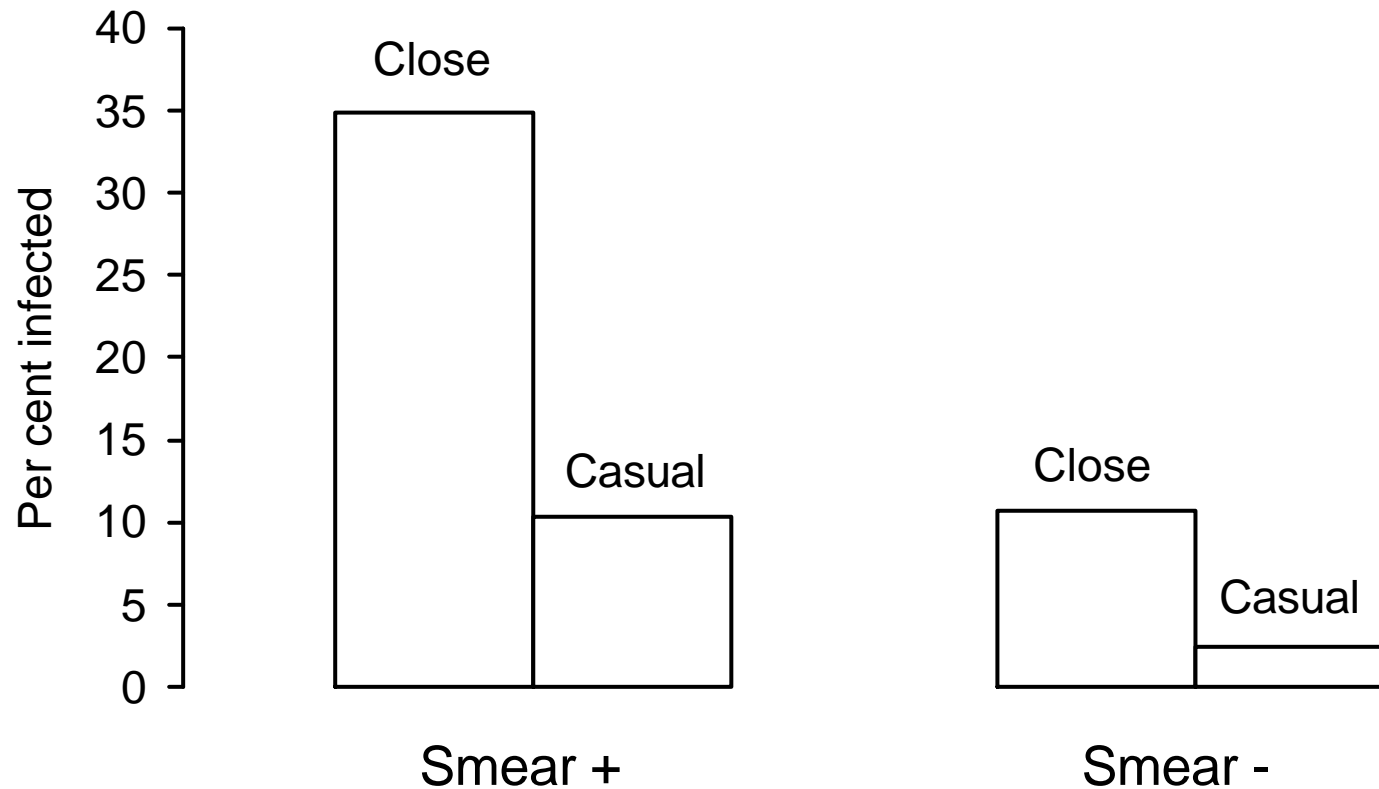

Grzybowski S, et al. Bull Int Union Tuberc 1975;50:90-106

Risk of Infection Among Contacts as a Function of the Proximity of Contact

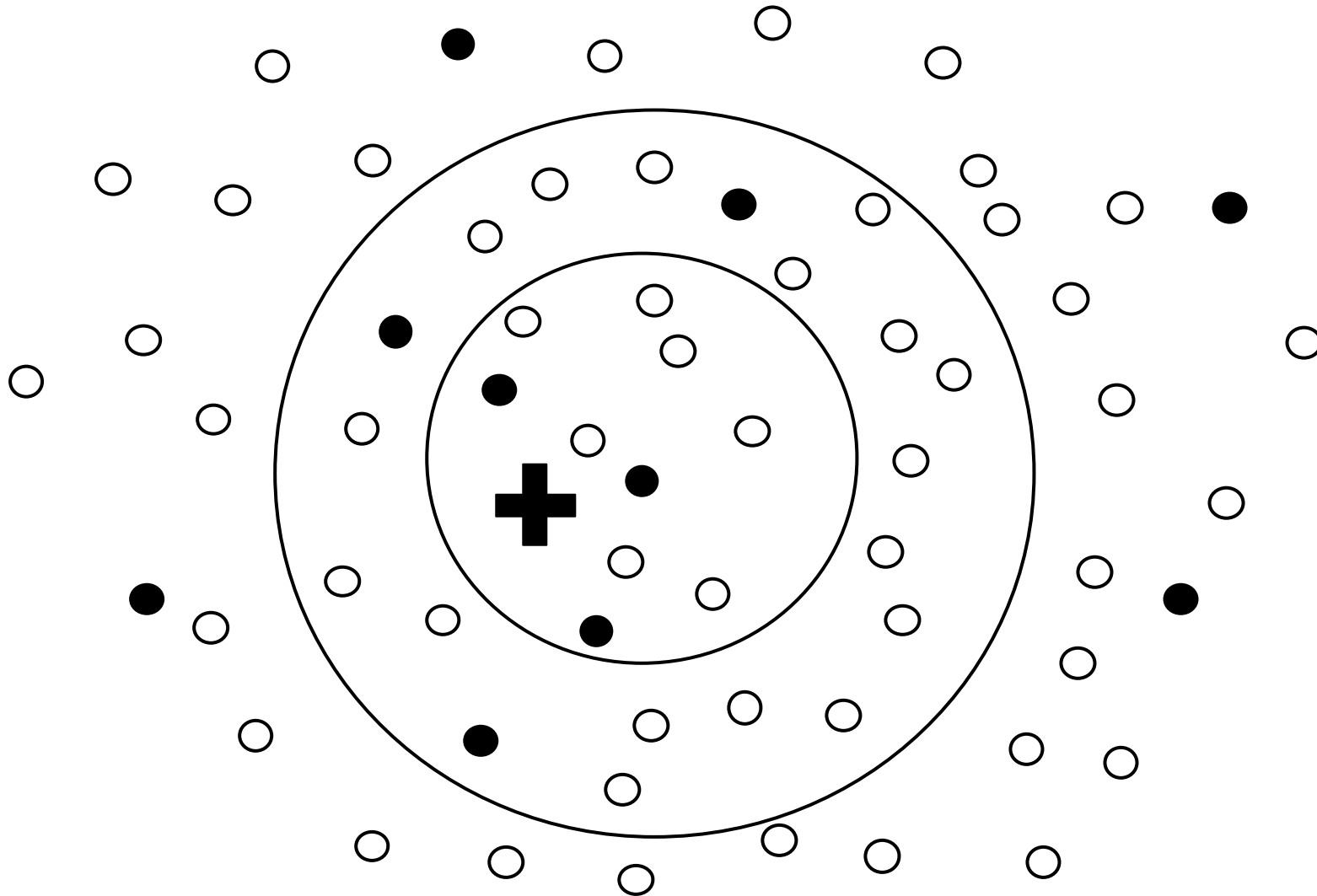

Percentage of Tuberculous Herds in Two Selected Counties, Denmark, 1937-1950

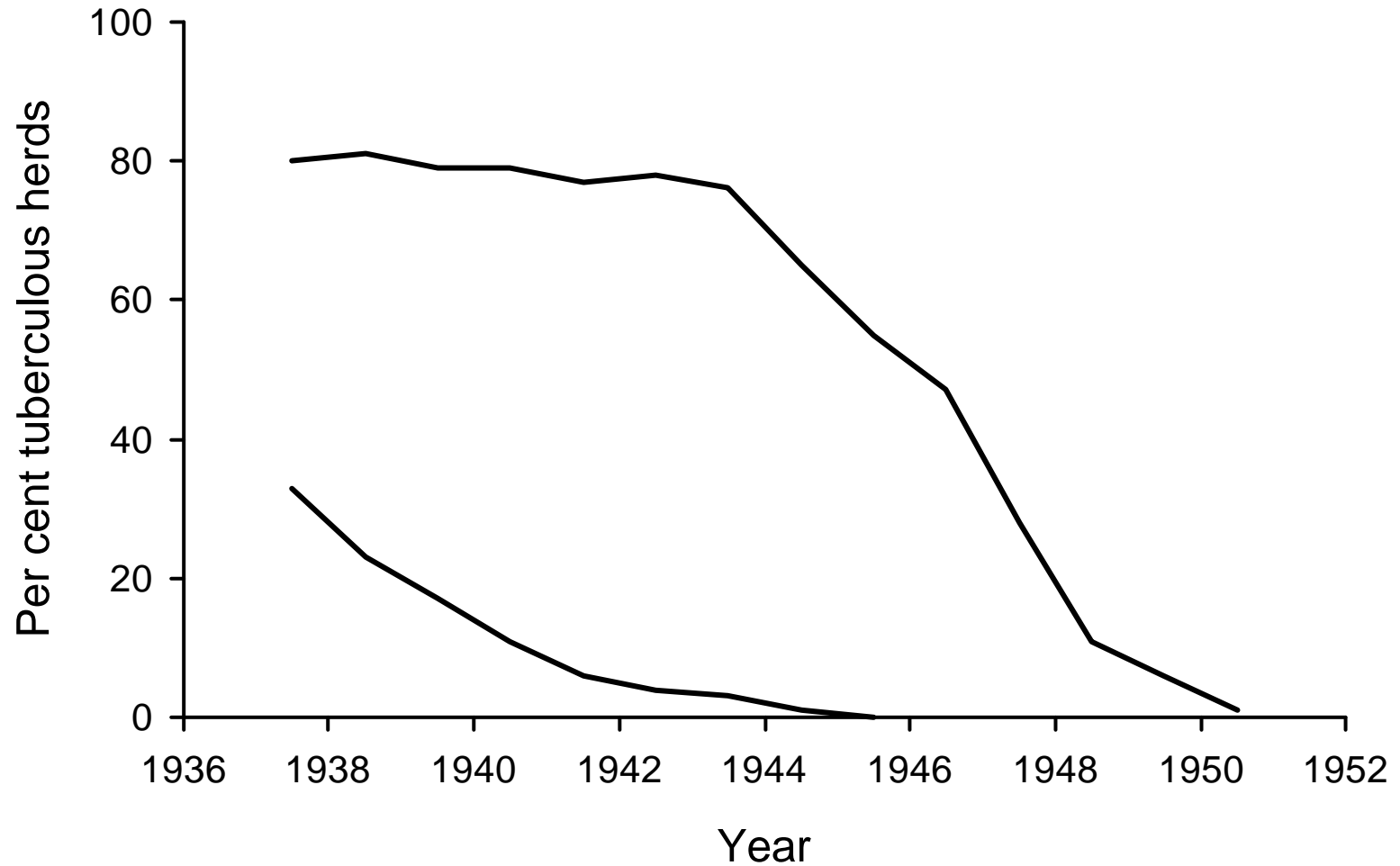

Magnus K. Danish Tuberculosis Index 1968:9-28

Correlation Between Tuberculous Herds (1937 - 1939) and Human Tuberculin Skin Test Reactors (1950 - 1952), Denmark

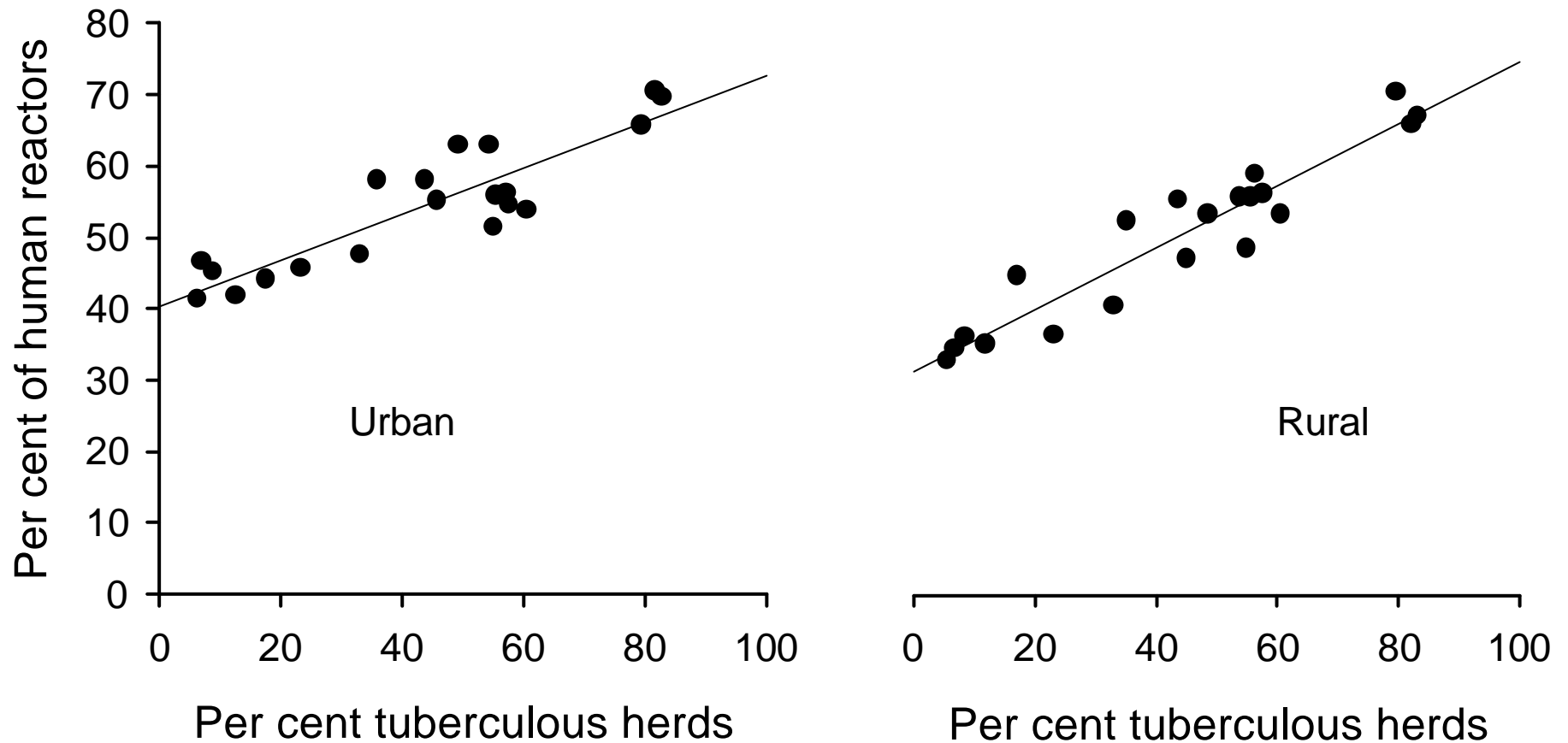

Correlation Between Prevalence of Tuberculin Reacting Cattle and Frequency of Cattle with no Lesion

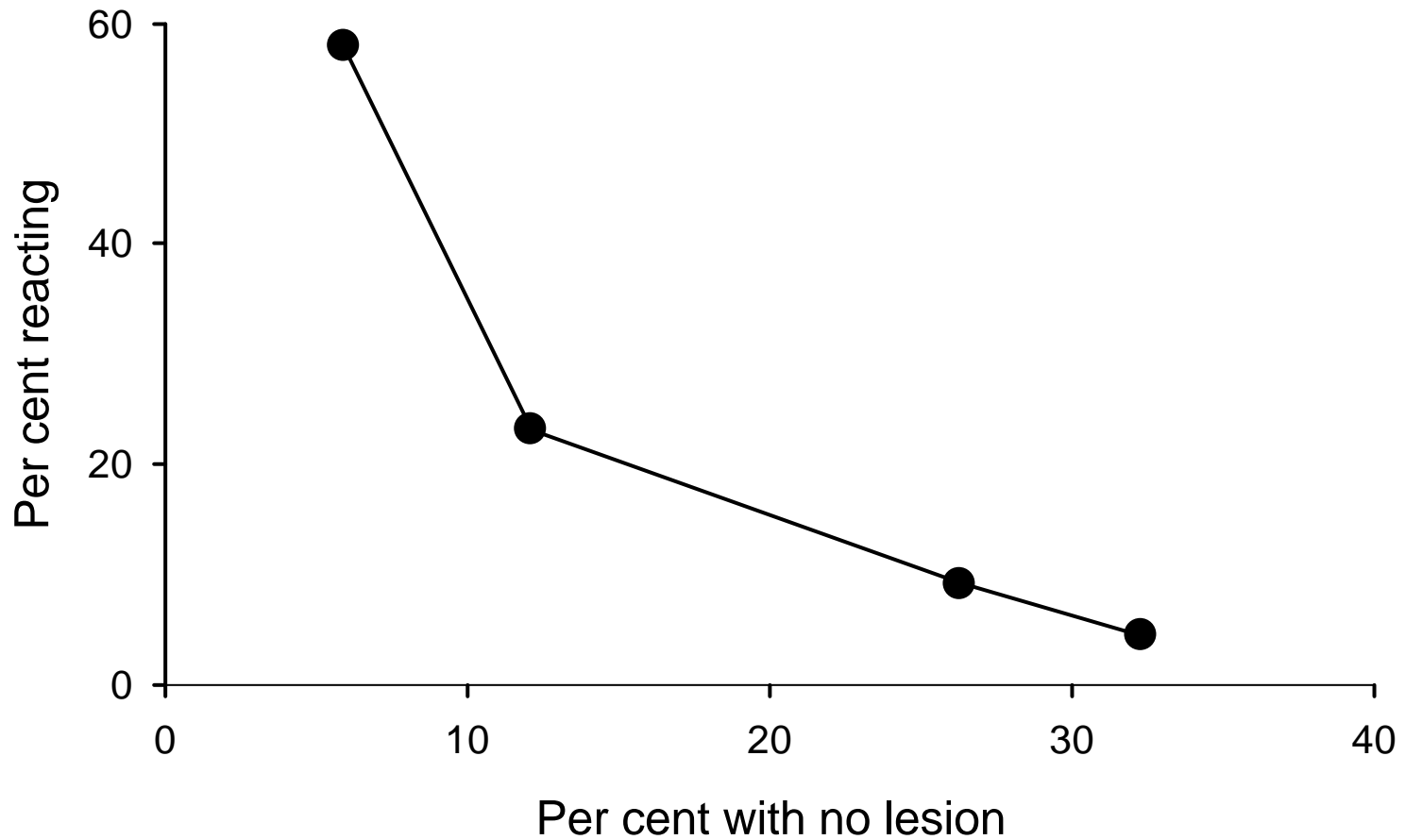

Hastings EG, et al. Am Rev Tuberc 1930;22:218-25

Cumulative Percentage of Children Reacting to Increasing Doses of Tuberculin, by History of Contact

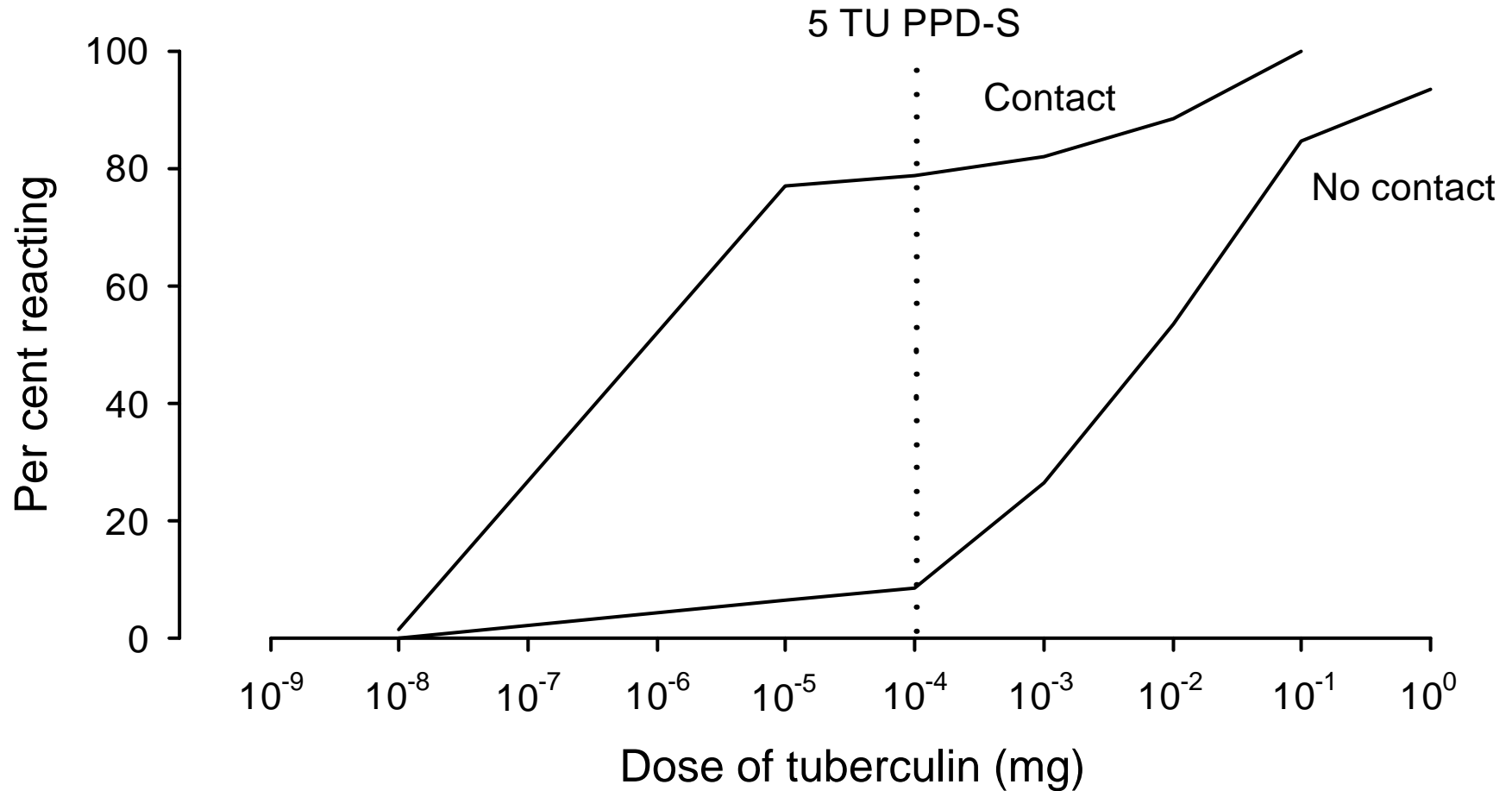

Furcolow ML, et al. Public Health Rep 1941;56:1082-1100

Cumulative Percentage of Children Reacting to Increasing Doses of Tuberculin, Among Healthy Children and Tuberculosis Patients

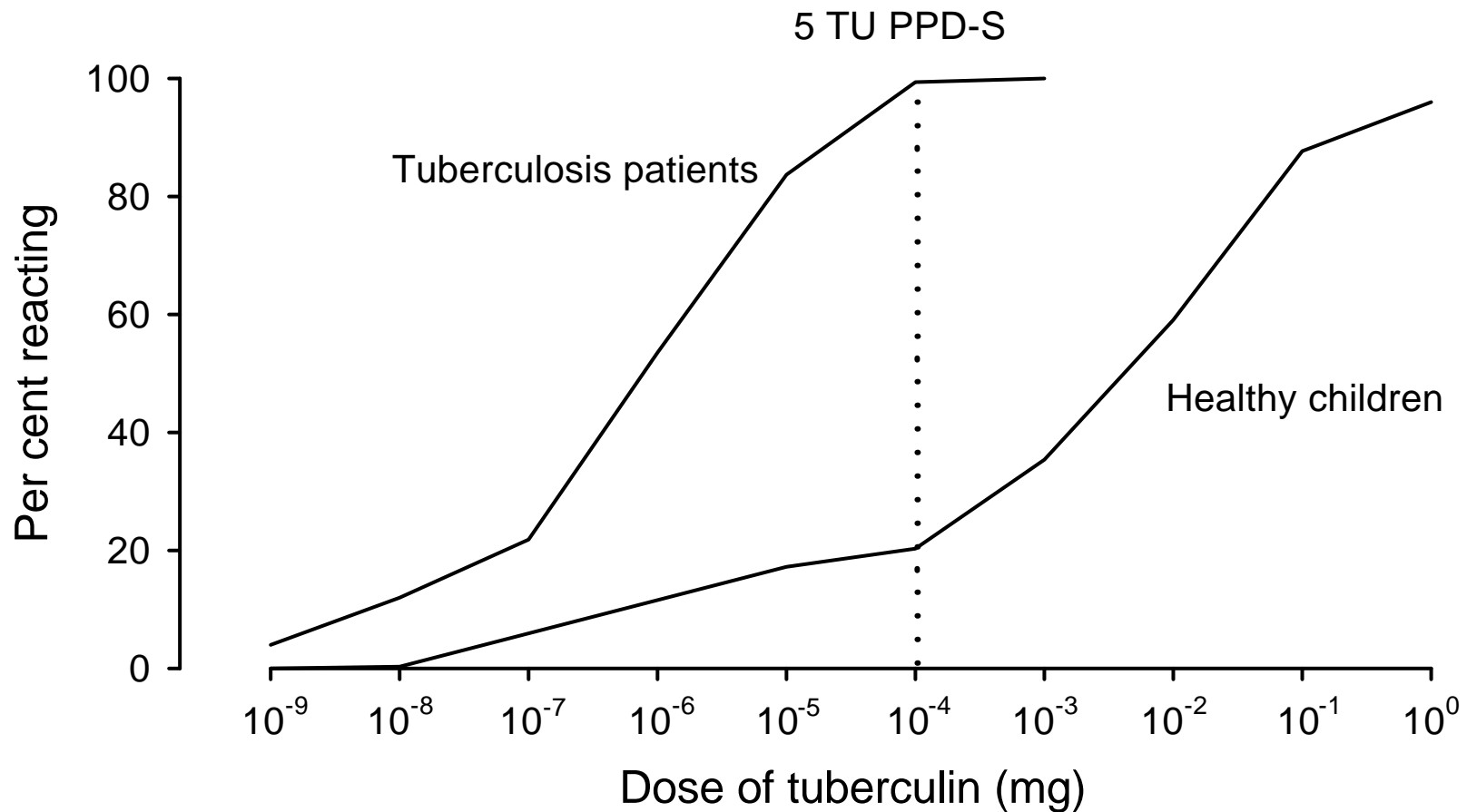

Furcolow ML, et al. Public Health Rep 1941;56:1082-1100

Relative Probability to React to 250 TU PPD-S Compared to 5 TU PPD-S, by Type of Contact

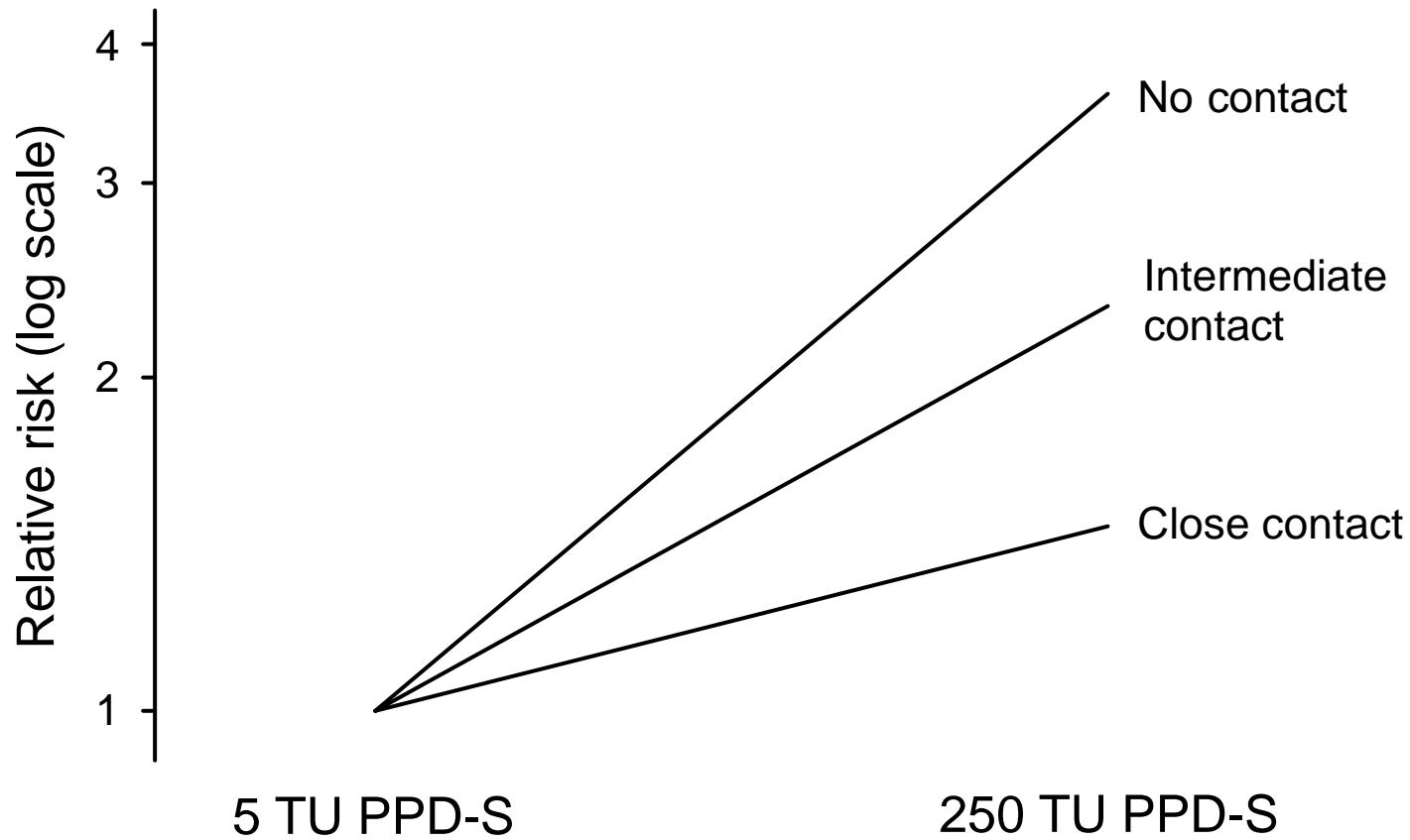

Comparison of Tuberculin PPD-S and PPD RT23 in Eskimo Children and United States Navy Recruits

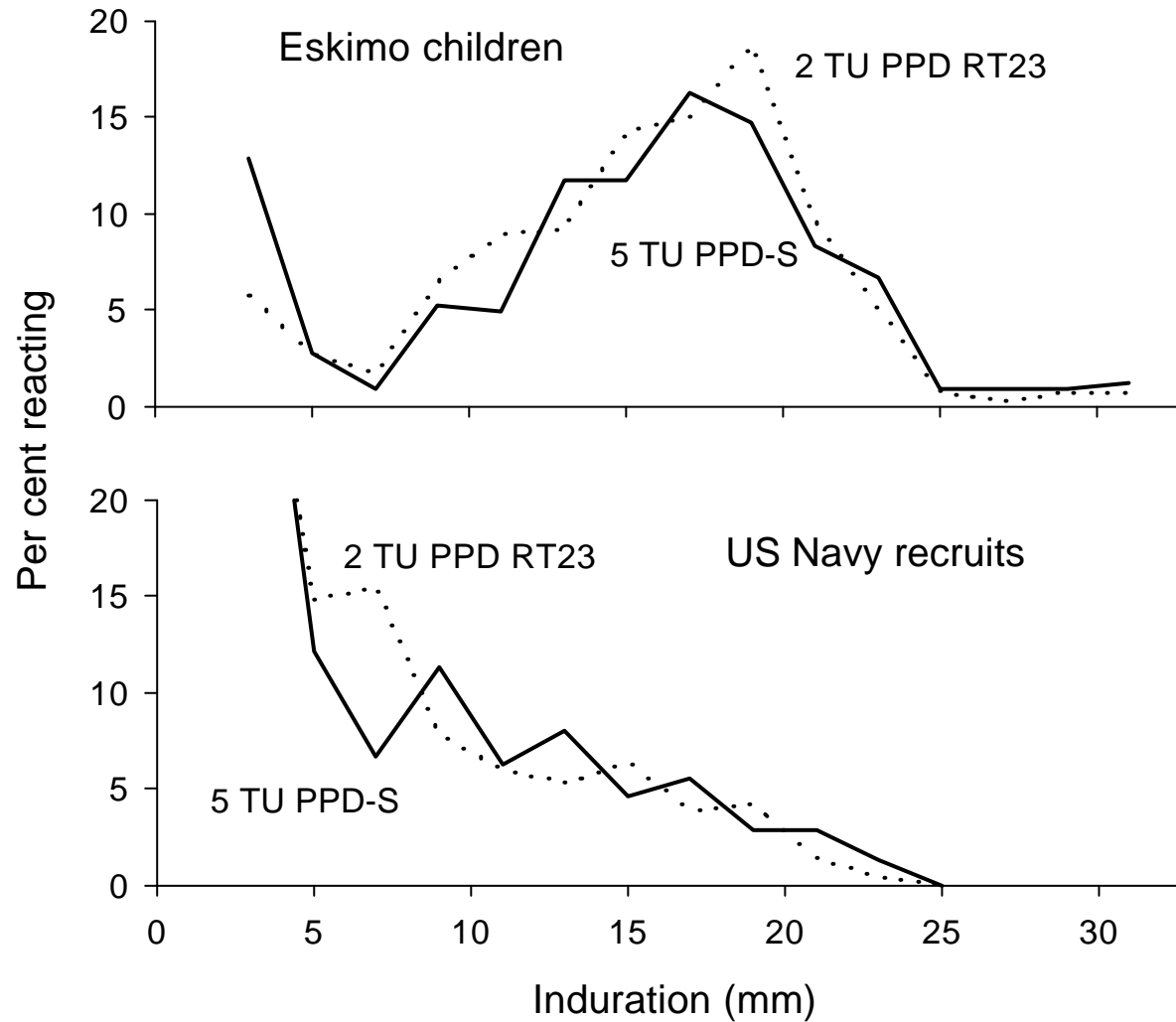

Frequency Distribution of Tuberculin Skin Test Results by Age, in Different Areas of the United States

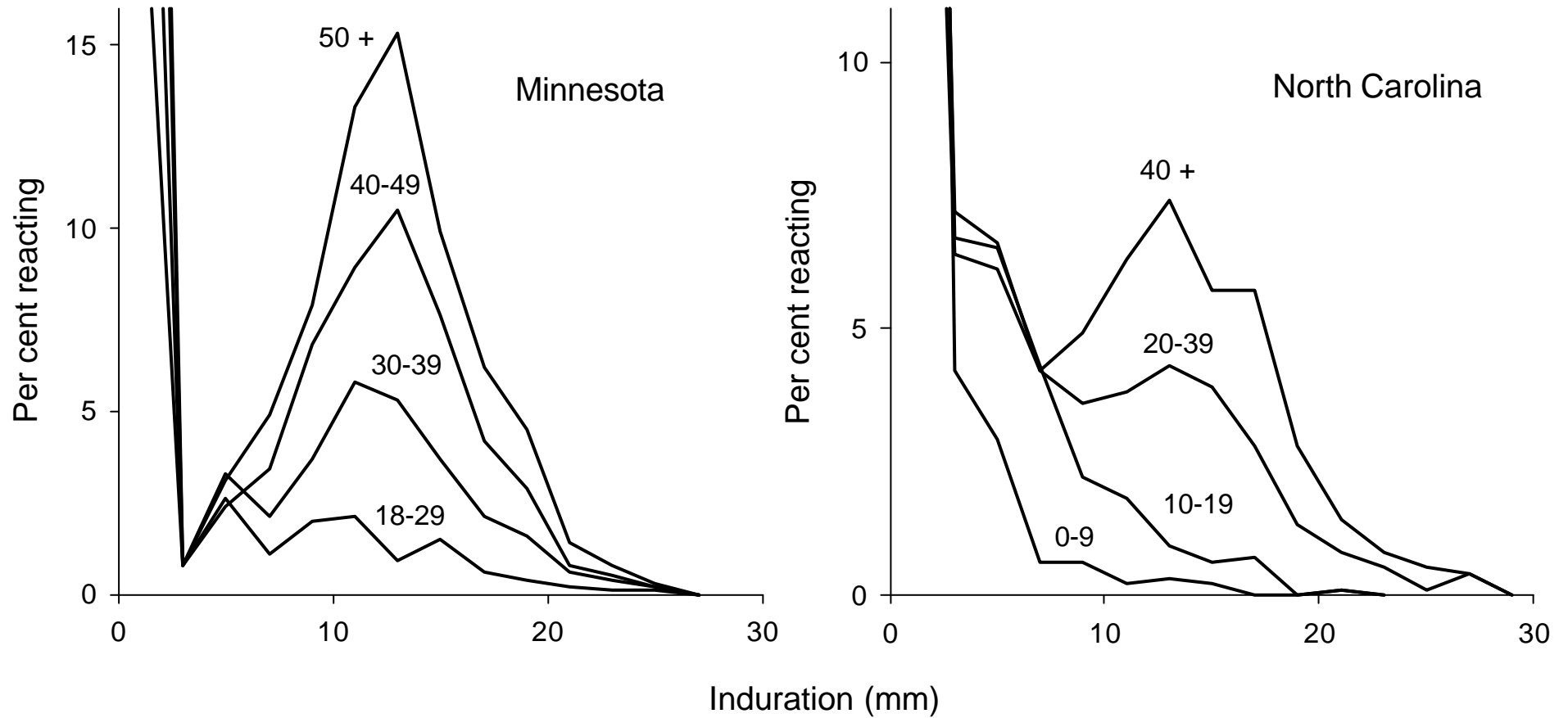

Distribution of Reaction Sizes to 5 TU Tuberculin PPD-S in 5,544 Tuberculosis Patients, United States

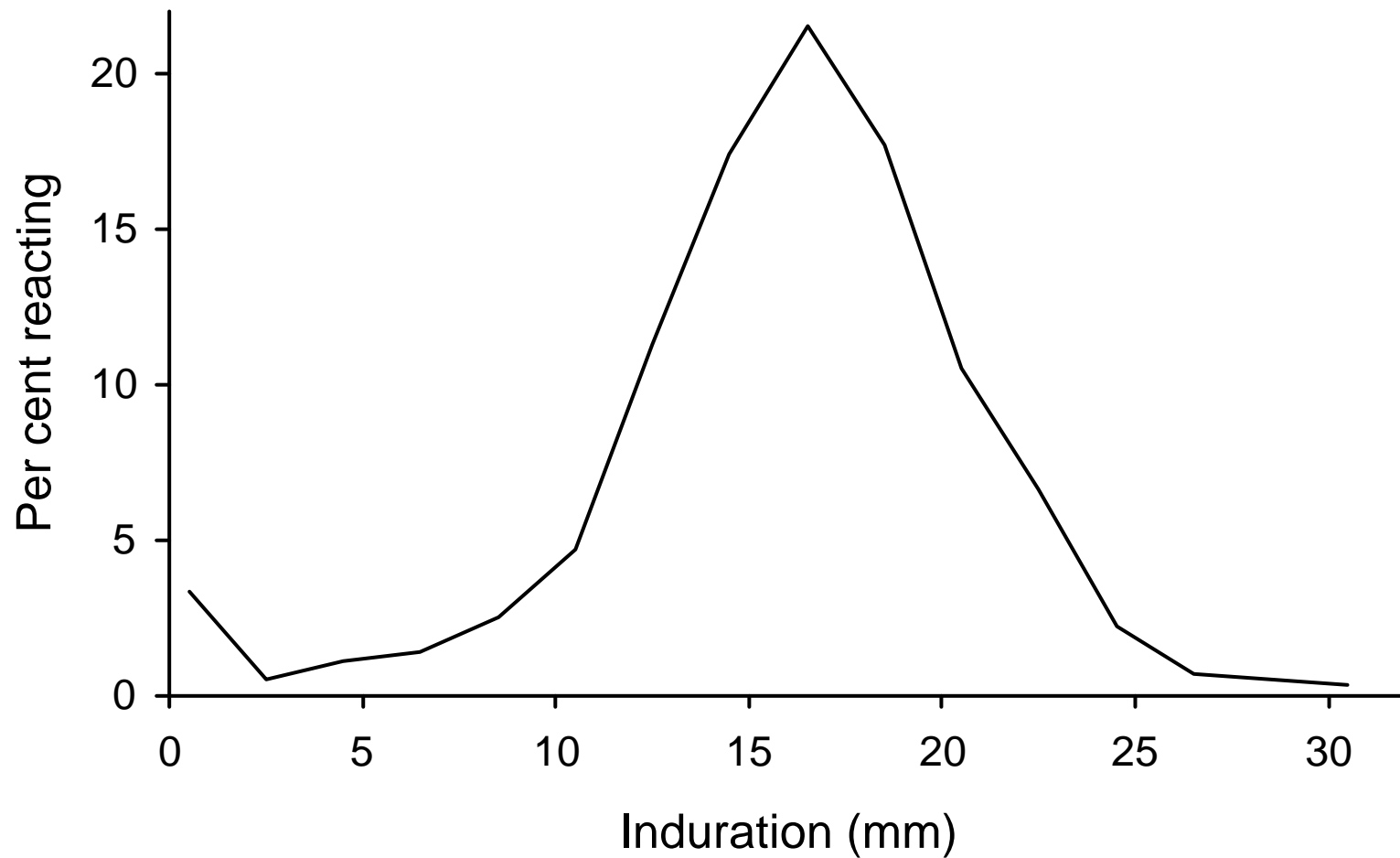

Edwards LB, et al. Am Rev Respir Dis 1969;99(4, part 2 of 2):1-132

Distribution of Reaction Sizes to 5 TU Tuberculin PPD-S Among Navy Recruits, by History of Contact, United States

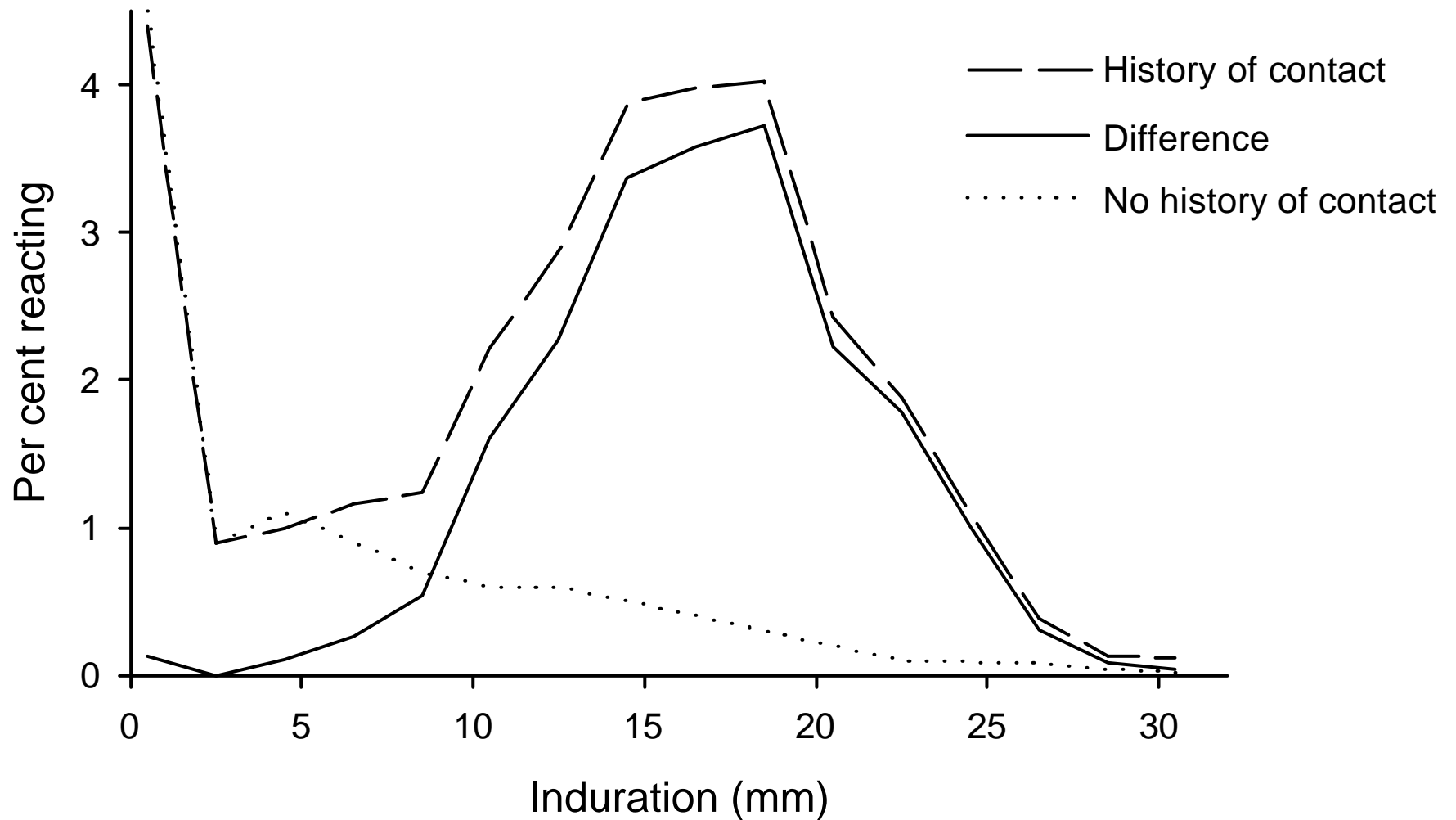

Figures accompanying monograph: Figure 20

Hans L. Rieder. Epidemiologic basis of tuberculosis control. Paris: International Union Against Tuberculosis and Lung Disease, 1999

This Figure is not available in this series.

Figure 20. Frequency of reactions to PPD-B in white United States Navy recruits who were lifetime residents of a single county, by county of origin.

Probability of Tuberculous Infection Among US Navy Recruits by Tuberculin Skin Test Size and History of Contact

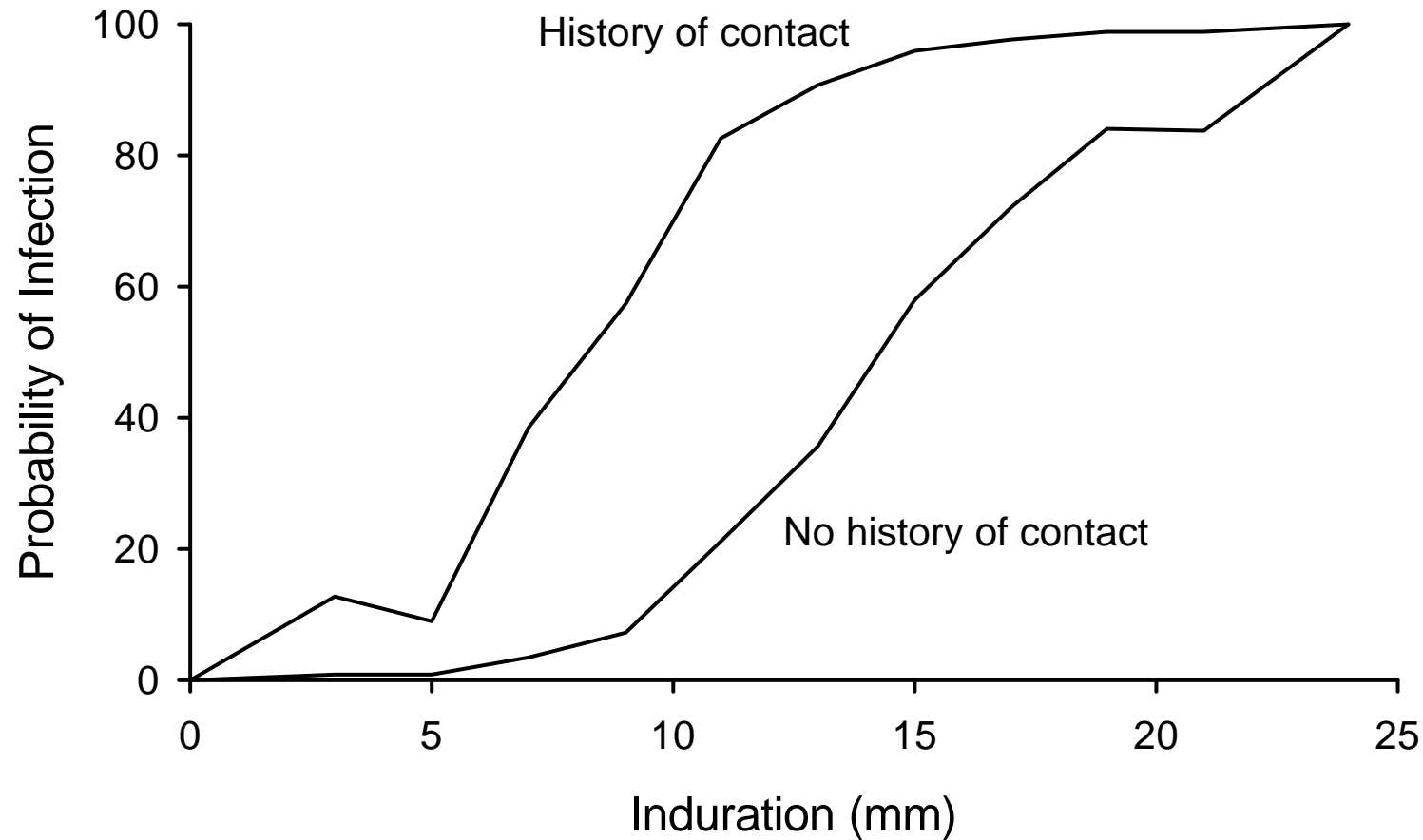

Frequency Distributions of Tuberculin Skin Test Reaction Sizes in Surveys in Tanzania and Djibouti

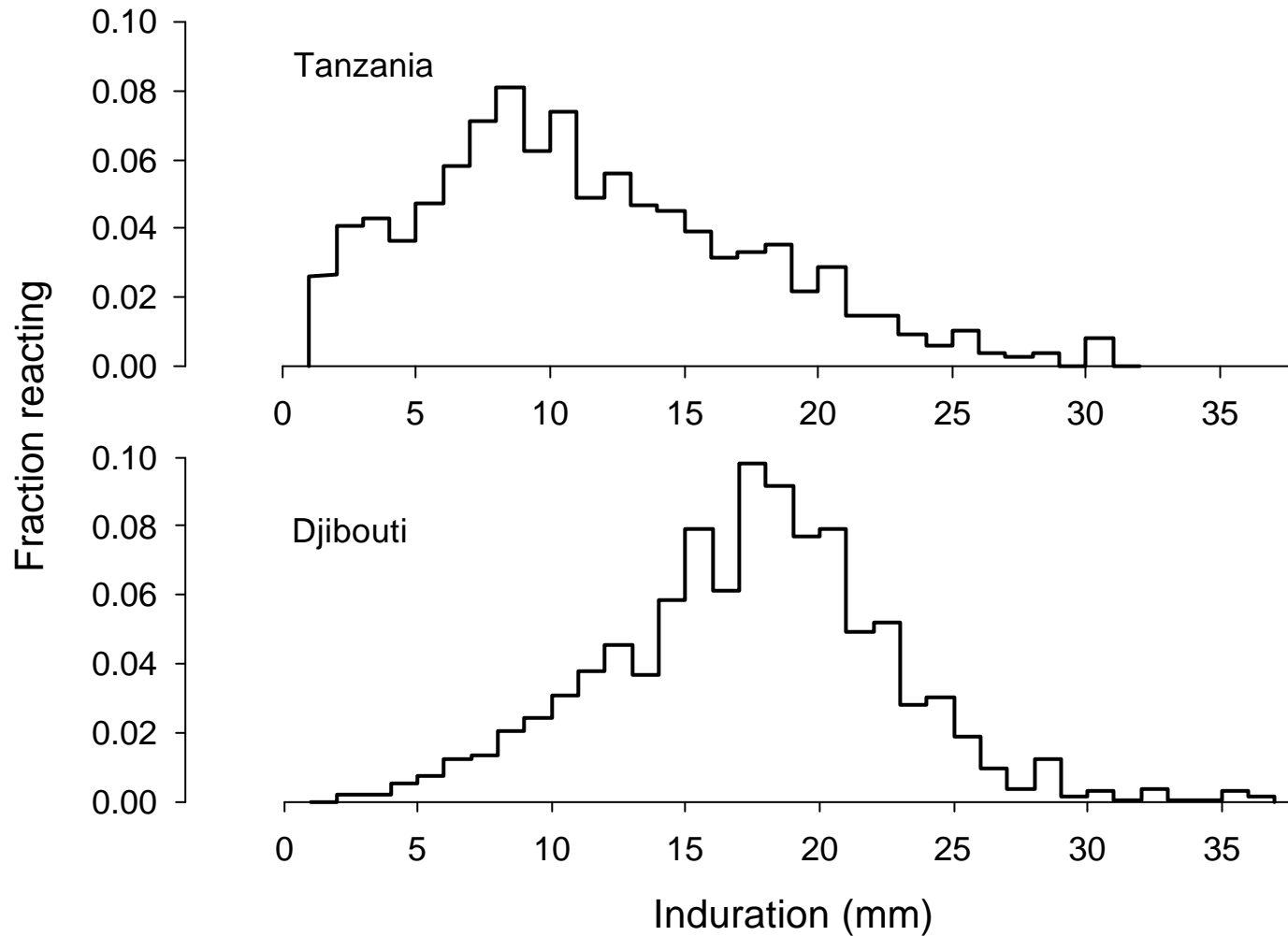

Styblo K. TSRU Progress Report 1998;1:31-66
Data courtesy Djibouti: Trébuçq A, IUATLD, 1995

Frequency Distribution of Tuberculin Skin Test Reaction Sizes, Korea 1975

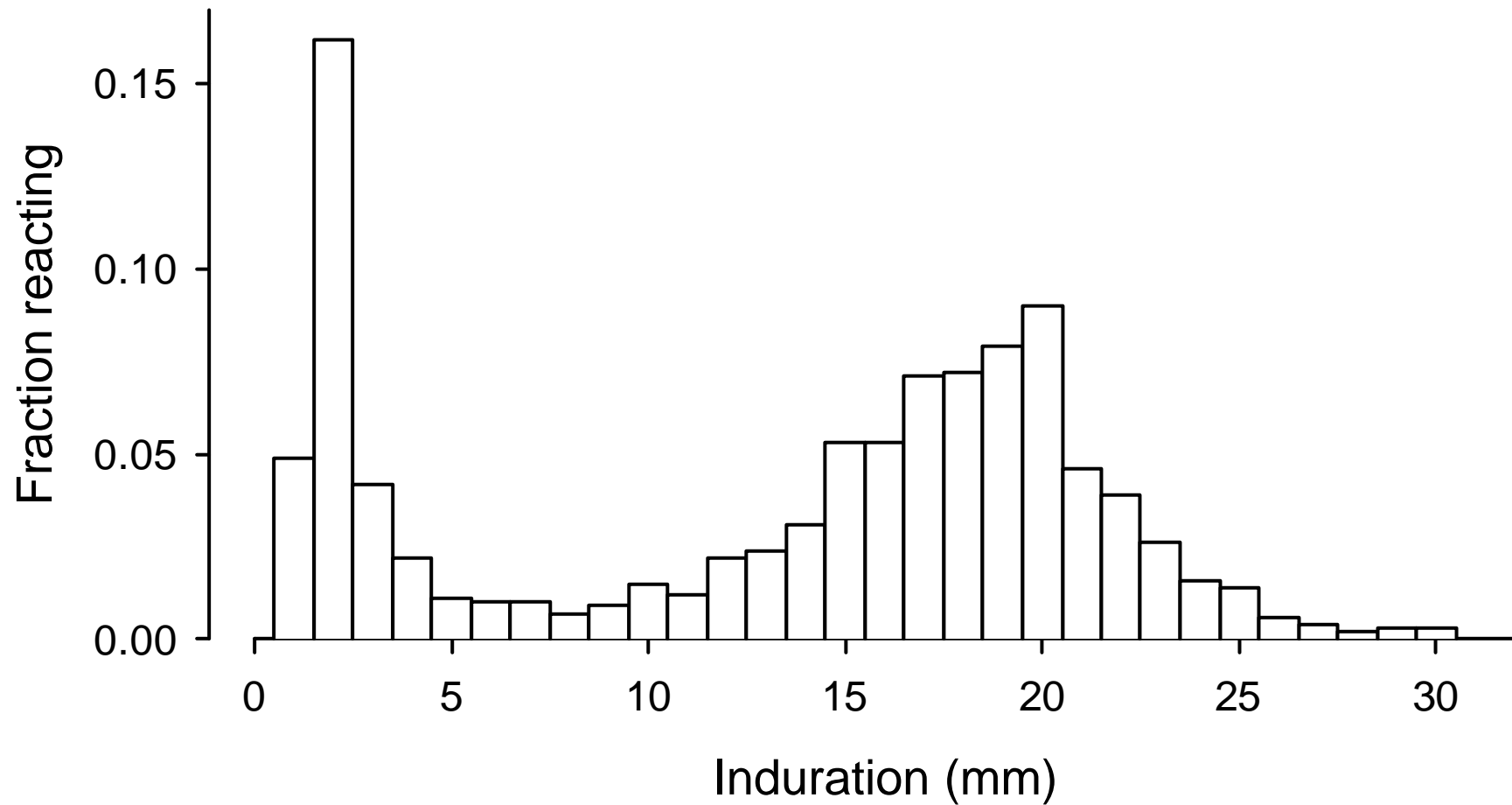

Korean Institute of Tuberculosis 1976:1-116

Tuberculin Skin Test Reaction Size Distribution in Two Tuberculin Surveys, Korea 1965 and 1995

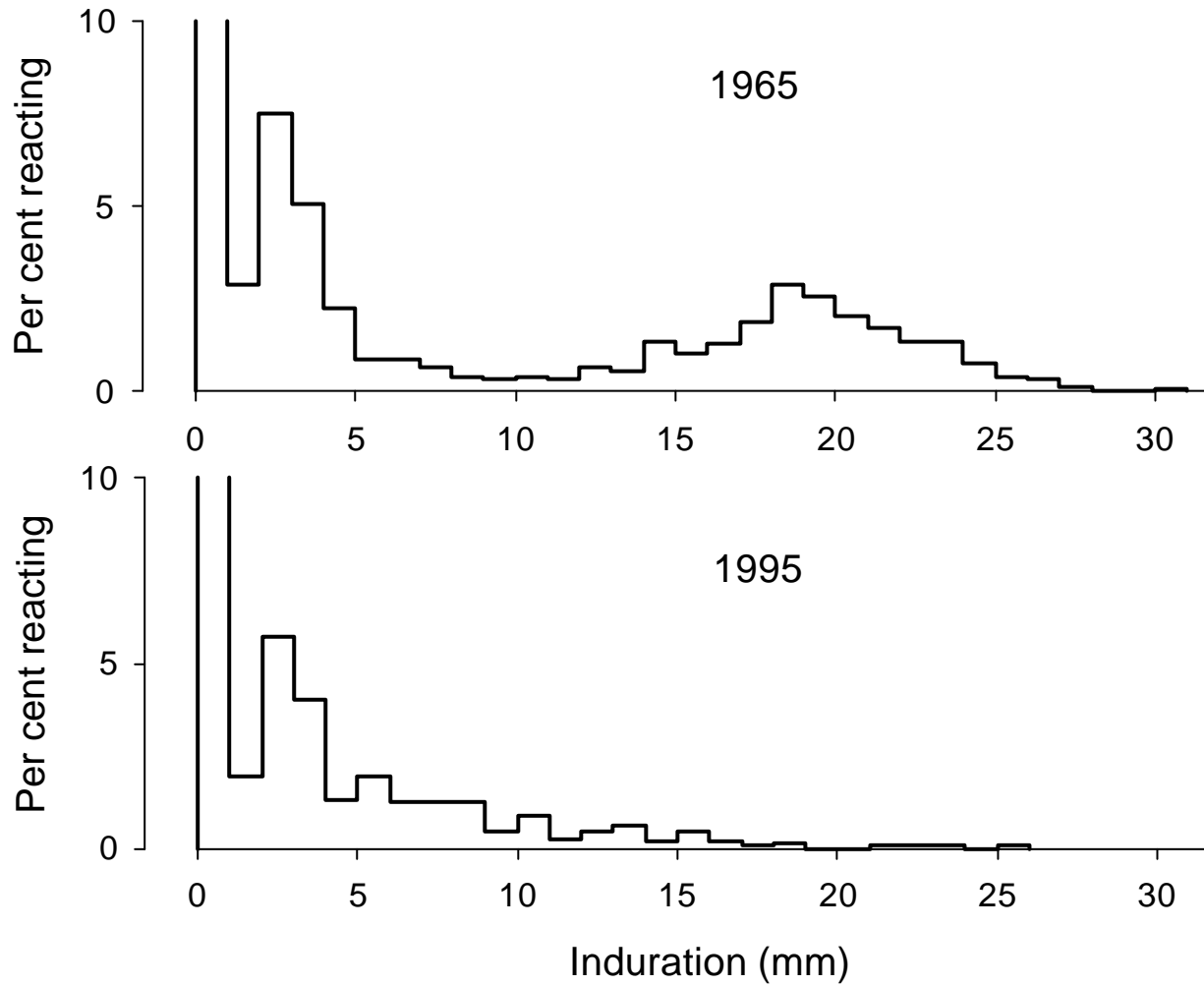

Korean Institute of Tuberculosis 1966:1-181
Korean National Tuberculosis Association 1996:1-180

Distribution of Tuberculin Skin Test Reactions 2 1/2 Months to 4 to 5 Years After BCG Vaccination in Madras and in Puerto Rico

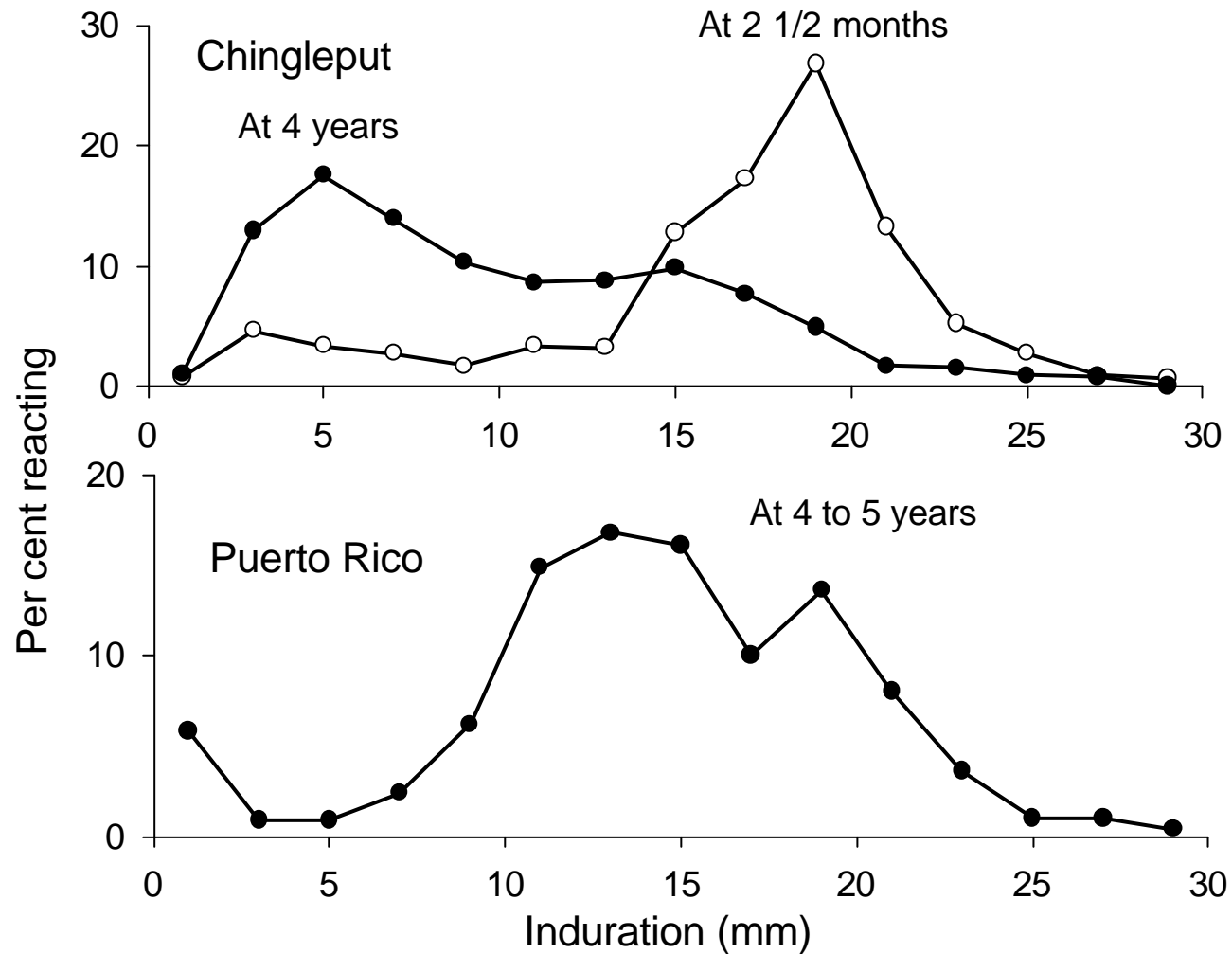

Tuberculosis Prevention Trial, Madras. Indian J Med Res 1980;72(suppl):1-74
Comstock GW, et al. Am J Public Health 1974;64:283-91

Example of a Composite Distribution Resulting from Specific and Non-Specific Reactions to Tuberculin

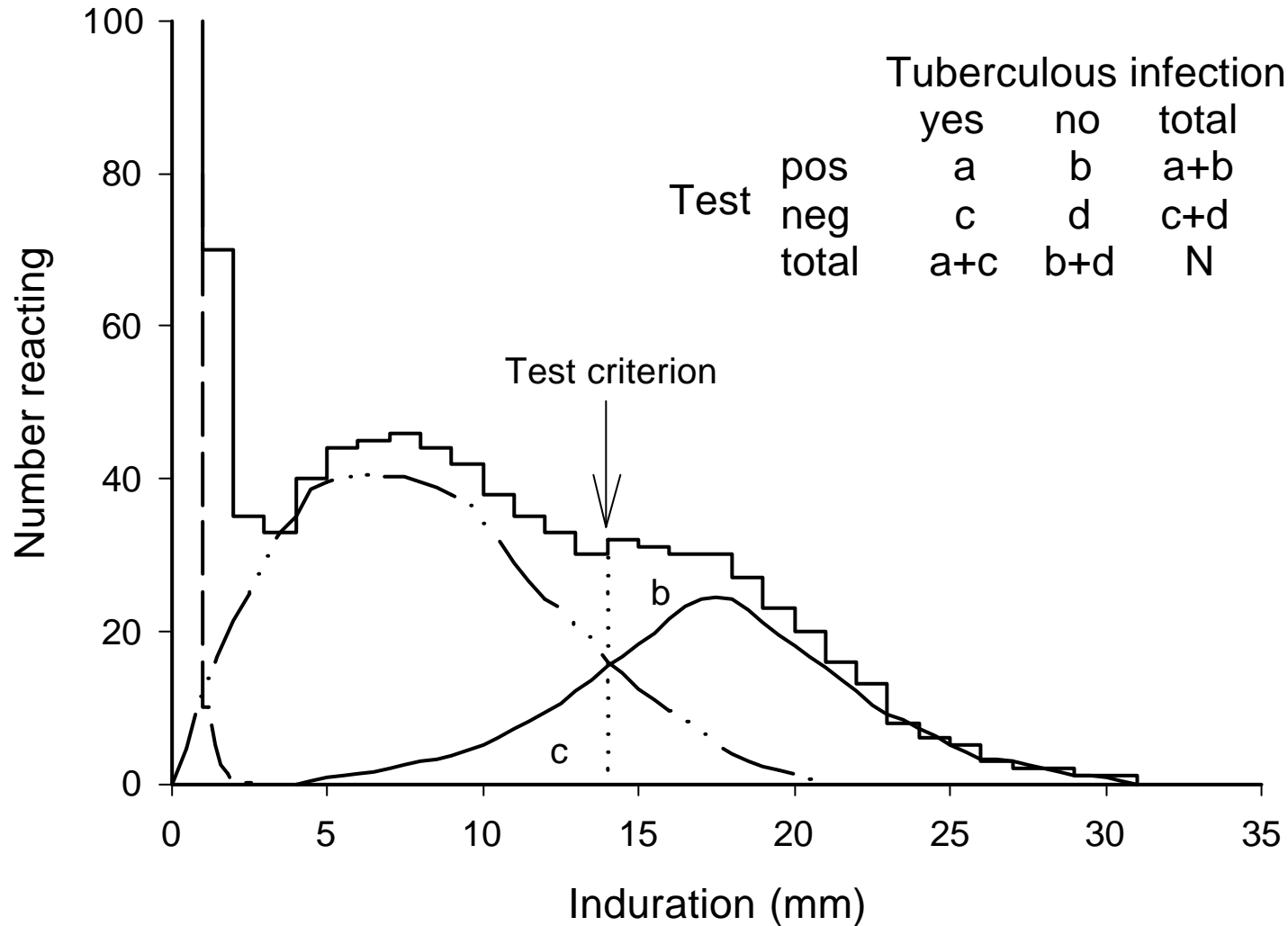

Tuberculin Skin Test Survey, Tanzania, 1988 - 1992 Observed and Mixture Components Distributions

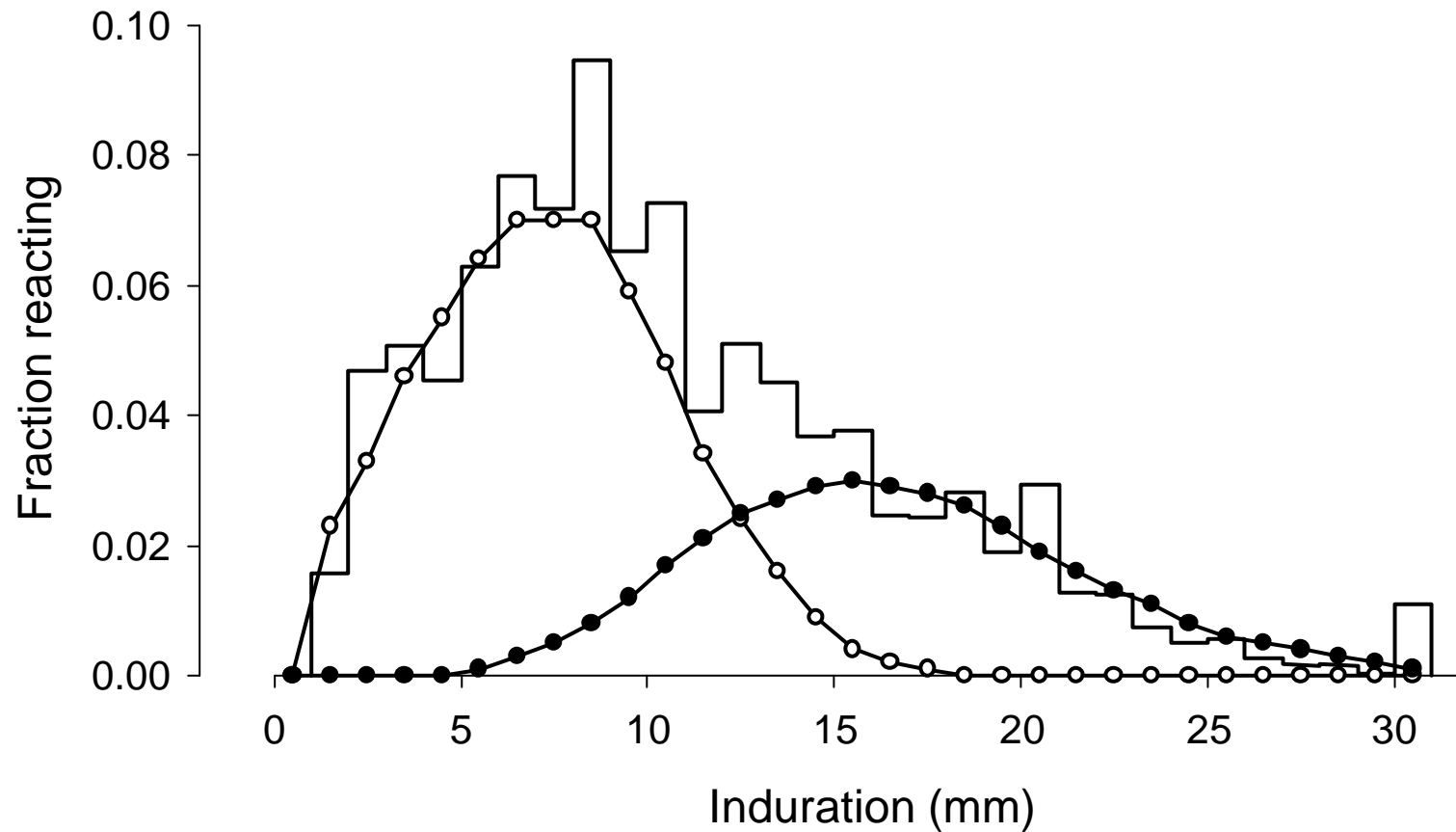

Data: Styblo K, et al. TSRU Progress Report 1995;1:140-91
Mixture model: Neuenschwander BE, et al. 1998

Age-Specific Prevalence of Tuberculous Infection in Healthy Children, Paris, 1910

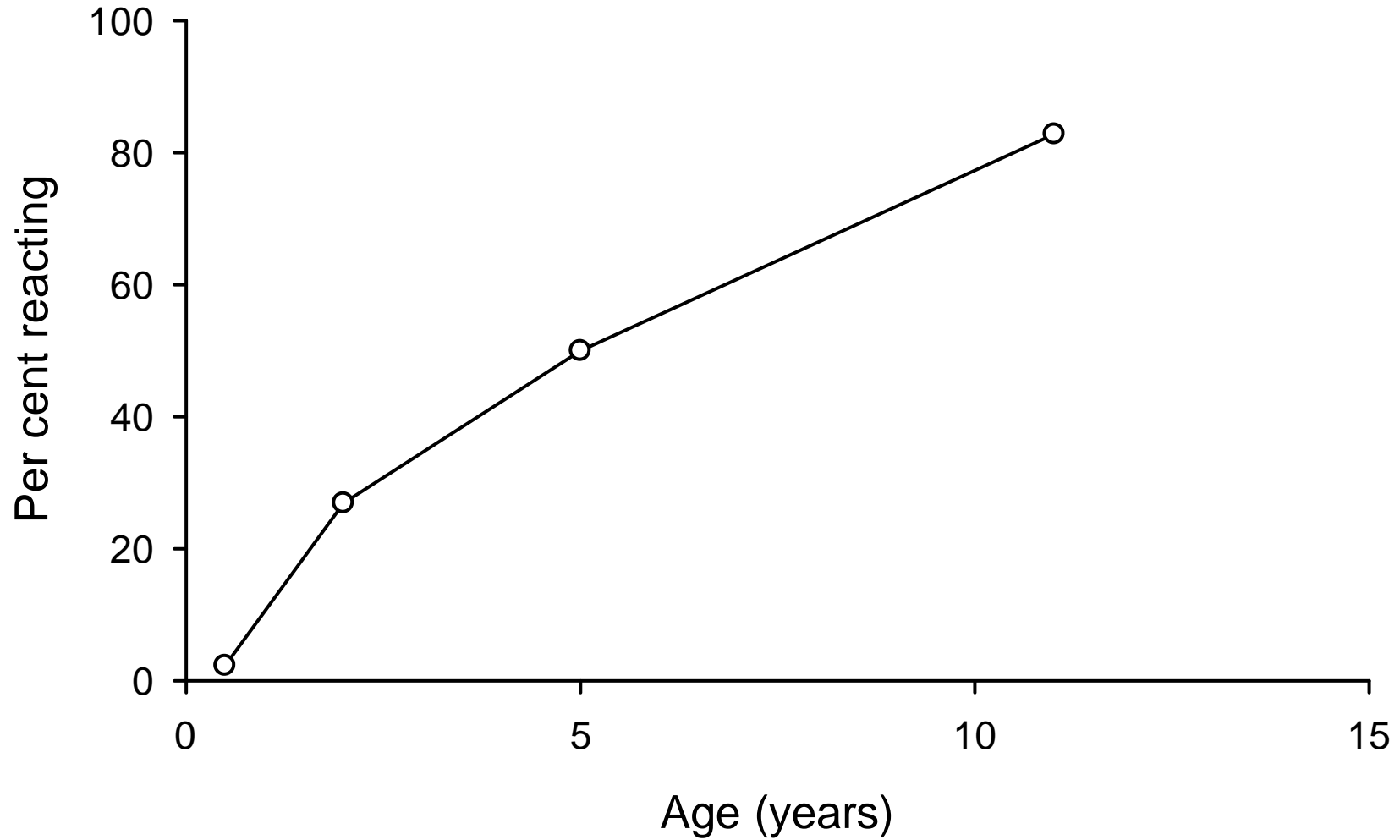

Mantoux C. Presse Méd 1910;2:10-13

Prevalence of Tuberculous Infection by Age and Sex, Denmark, 1950 - 1952

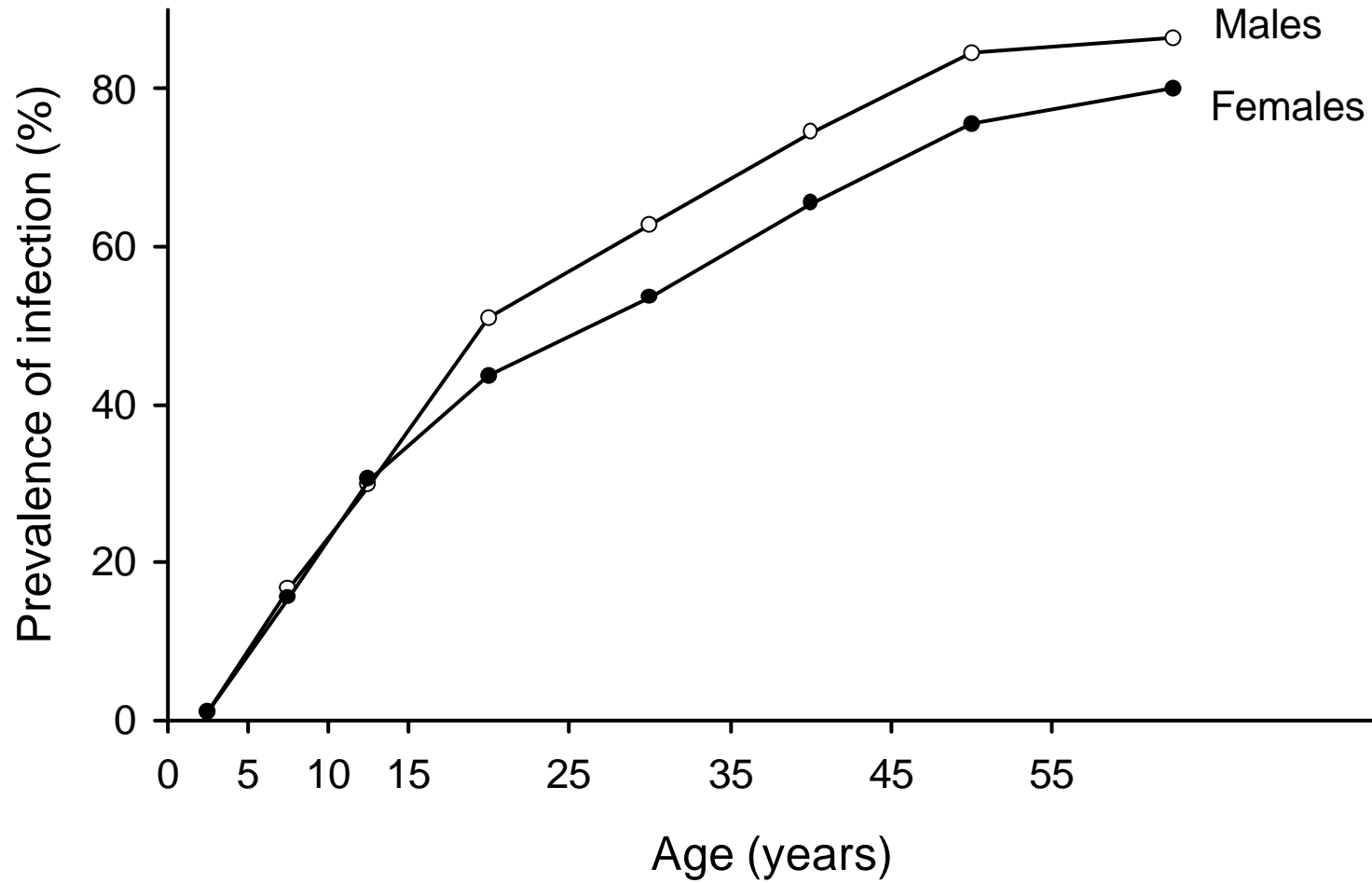

Groth-Petersen E, et al. Bull World Health Organ 1959;5:5-49

Prevalence of Tuberculous Infection by Age and Sex, India, 1961 - 1962

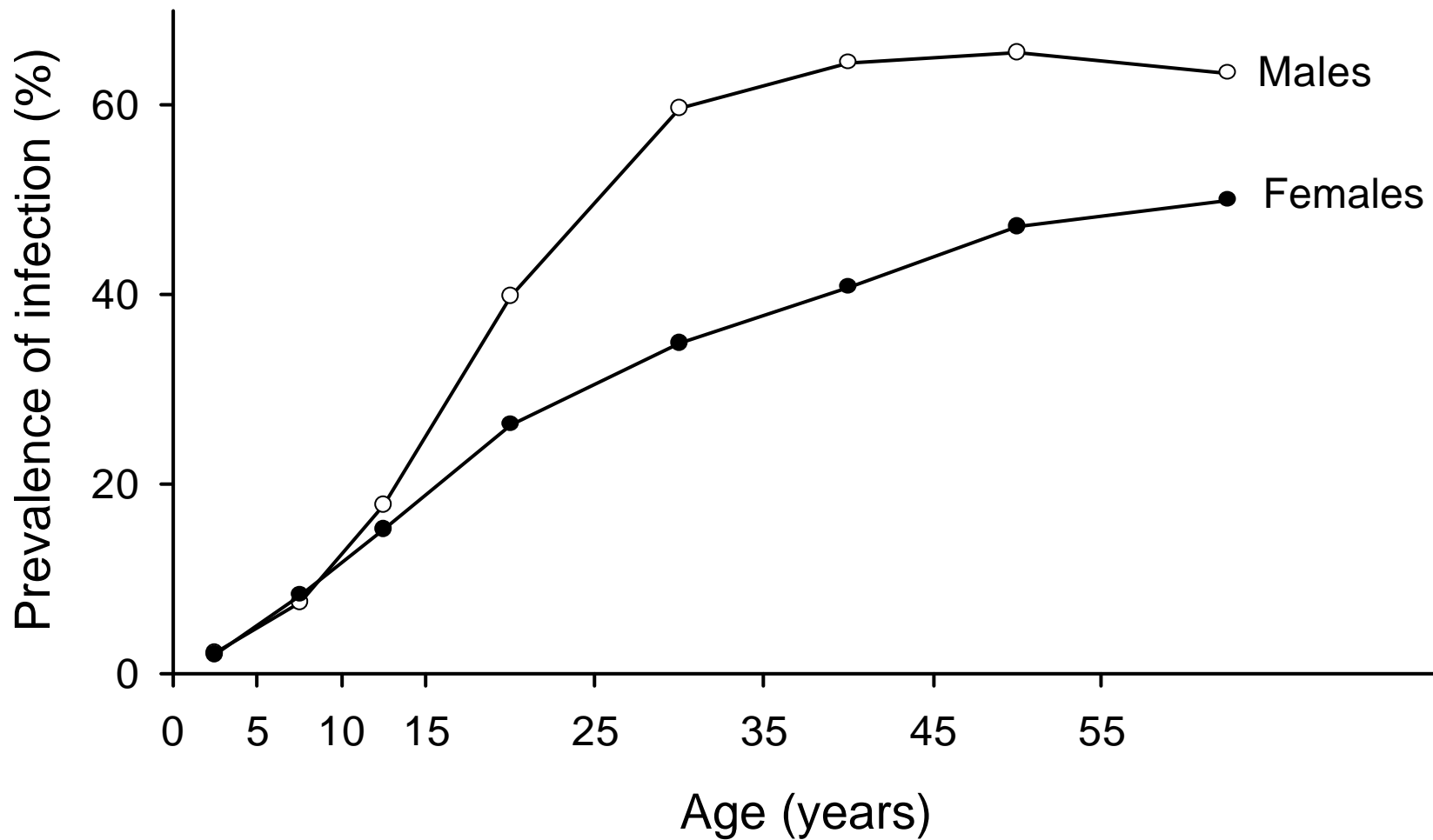

National Tuberculosis Institute Bangalore. Bull World Health Organ 1974;51:473-88

Male-to Female Ratio in Prevalence of Tuberculous Infection by Age, India 1961-1962 and Denmark, 1950-52

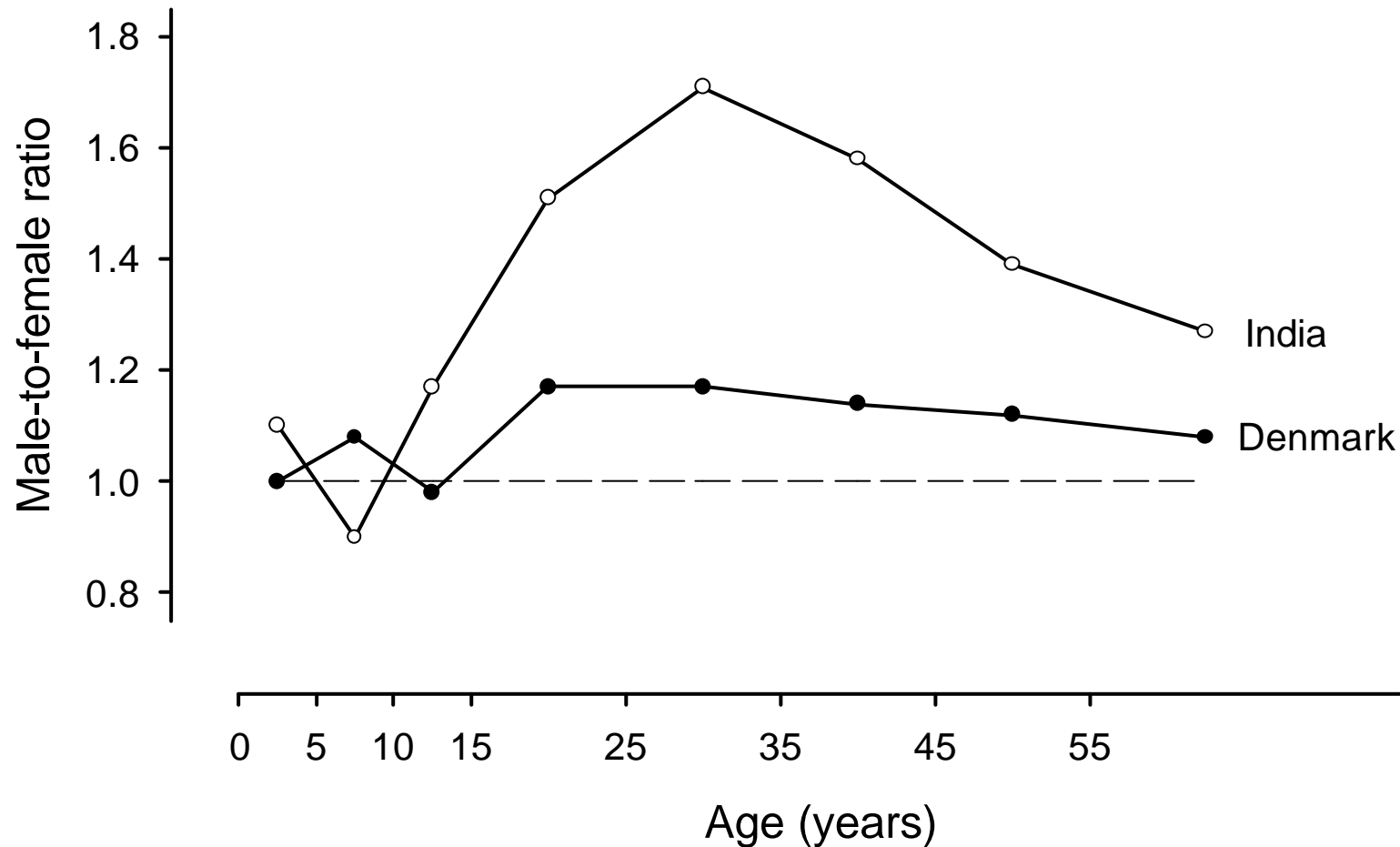

National Tuberculosis Institute Bangalore. Bull World Health Organ 1974;51:473-88

Groth-Petersen E, et al. Bull World Health Organ 1959;21:5-49

Age-Specific Prevalence of Tuberculous Infection in Cross-Sectional Surveys in Switzerland

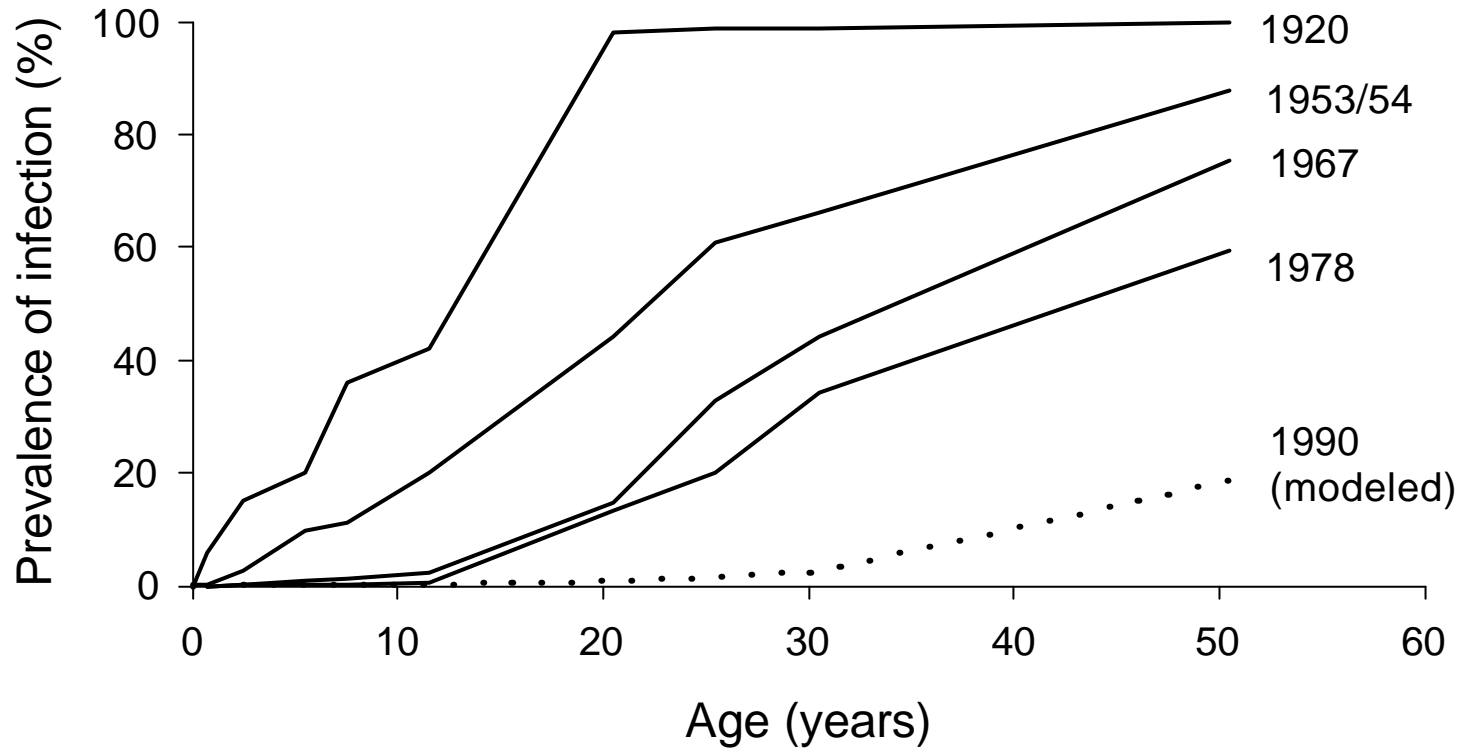

Zuberbühler JG. Thesis, University of Zürich, 1981:1-121

Hofer S. Thesis, University of Zürich 1982;1-45

Haefliger E. Prax Klin Pneumol 1982;36:335-64

Haefliger E. Therapiewoche Schweiz 1989;5:855-66

Rieder HL, et al. Schweiz Med Rundschau 1990;79:675-9

Prevalence of Tuberculous Infection (10+ mm) by Age, Korea, 1965 - 1995

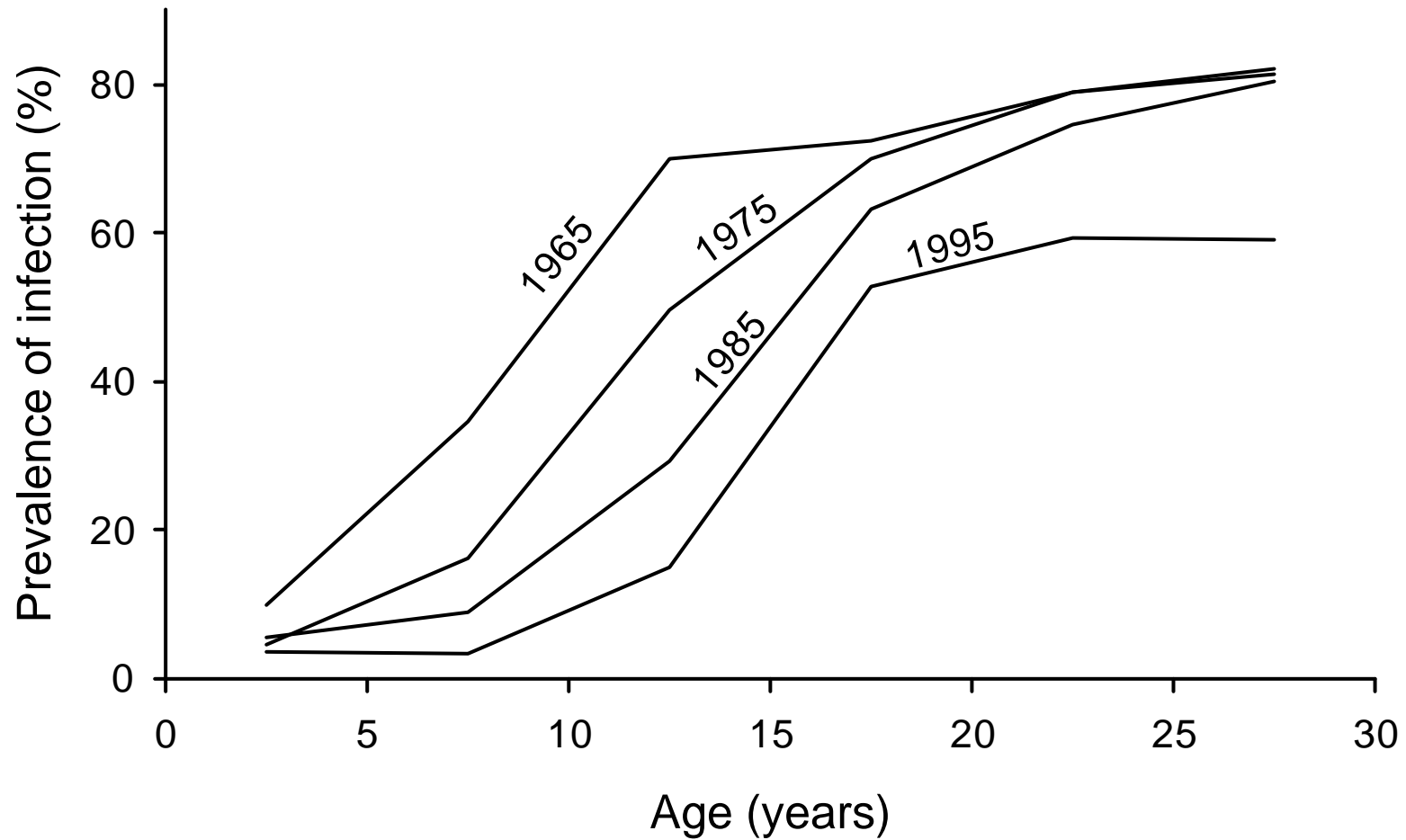

Korean Institute of Tuberculosis, 1965 - 1995

Prevalence of Tuberculous Infection by Age and Residence, Korea, 1965

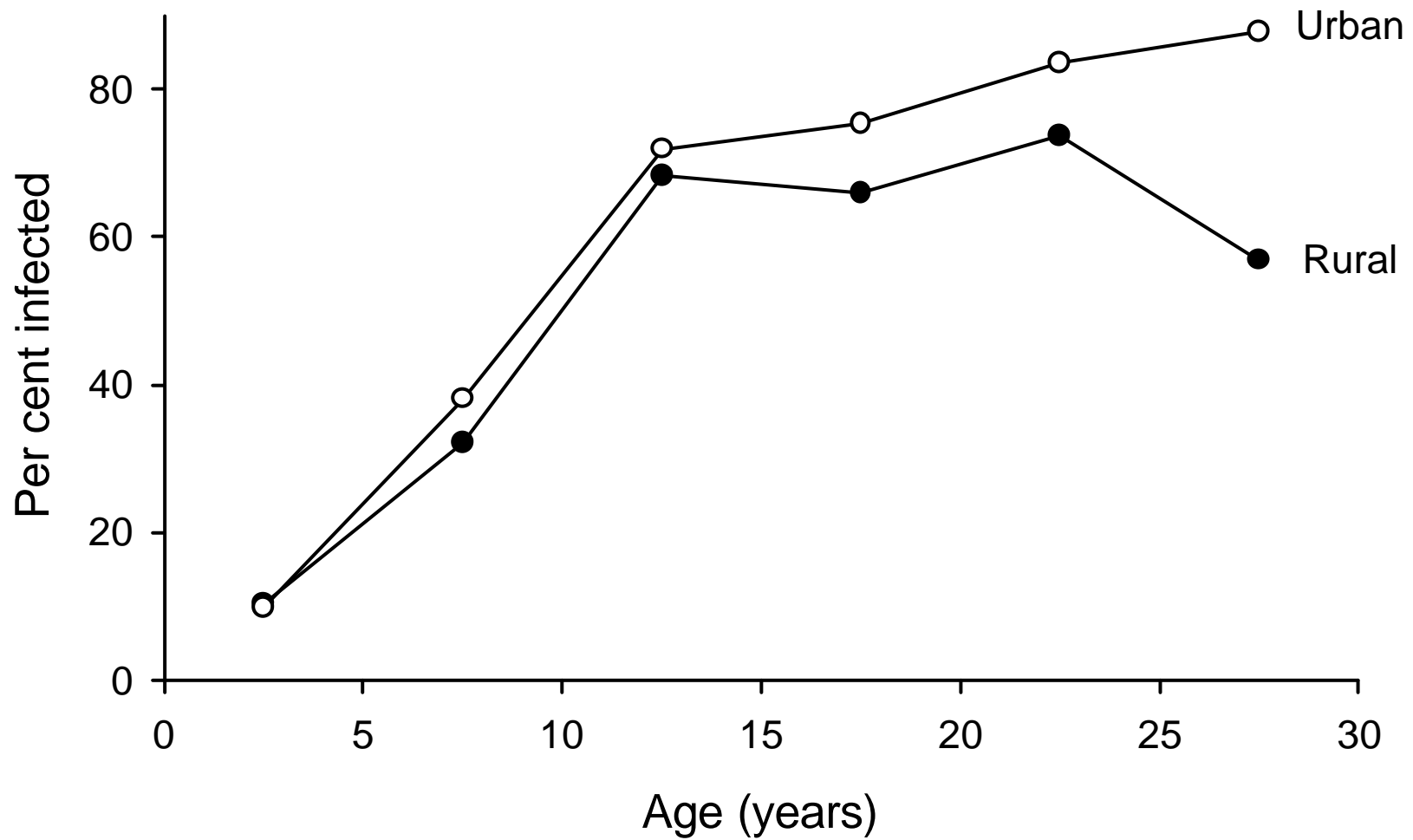

Korean Institute of Tuberculosis, 1966

Prevalence of Tuberculous Infection by Age and Residence, in Zanzibar, 1961

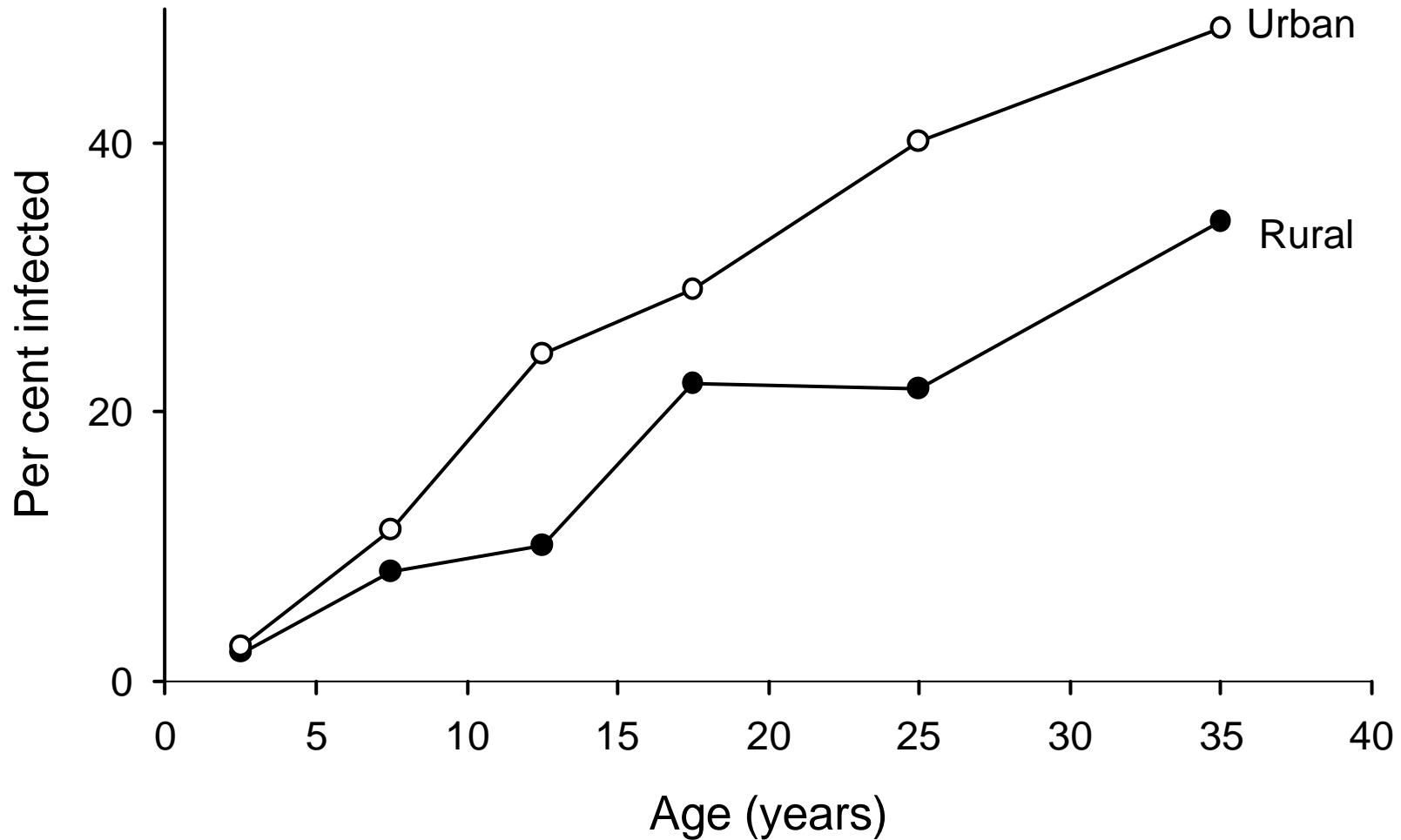

Roelsgaard E, et al. Bull World Health Organ 1964;30:459-518

Prevalence of Tuberculous Infection by Age and Socioeconomic Status in Heidelberg, Trondheim, and Hué, 1910 - 1920

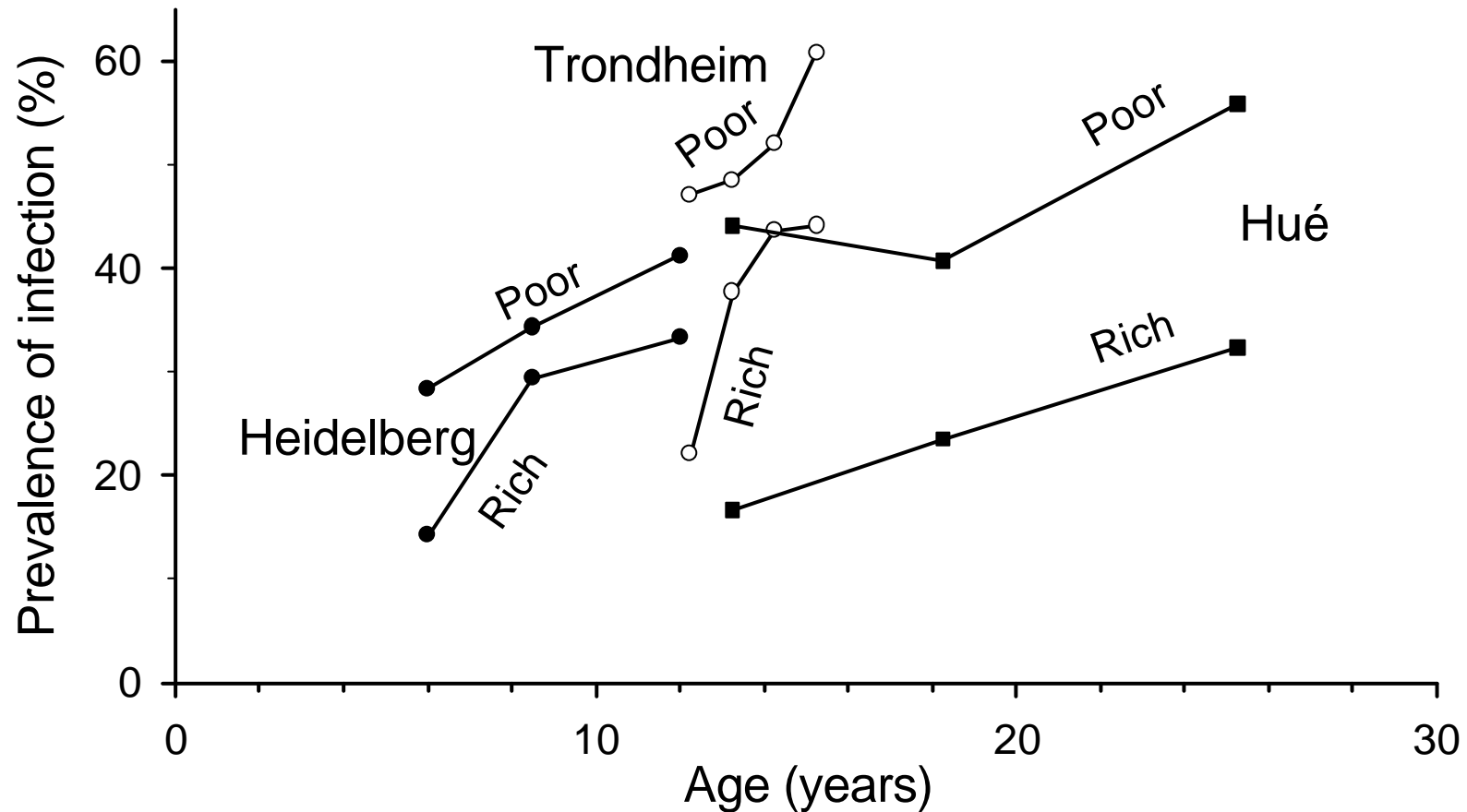

D'Arcy Hart P. Br Med Res Council Spec Ser 1932;No. 164:5-132

Frequency of Large Tuberculin Skin Test Reactions Among High School Students, Washington County, USA, 1963

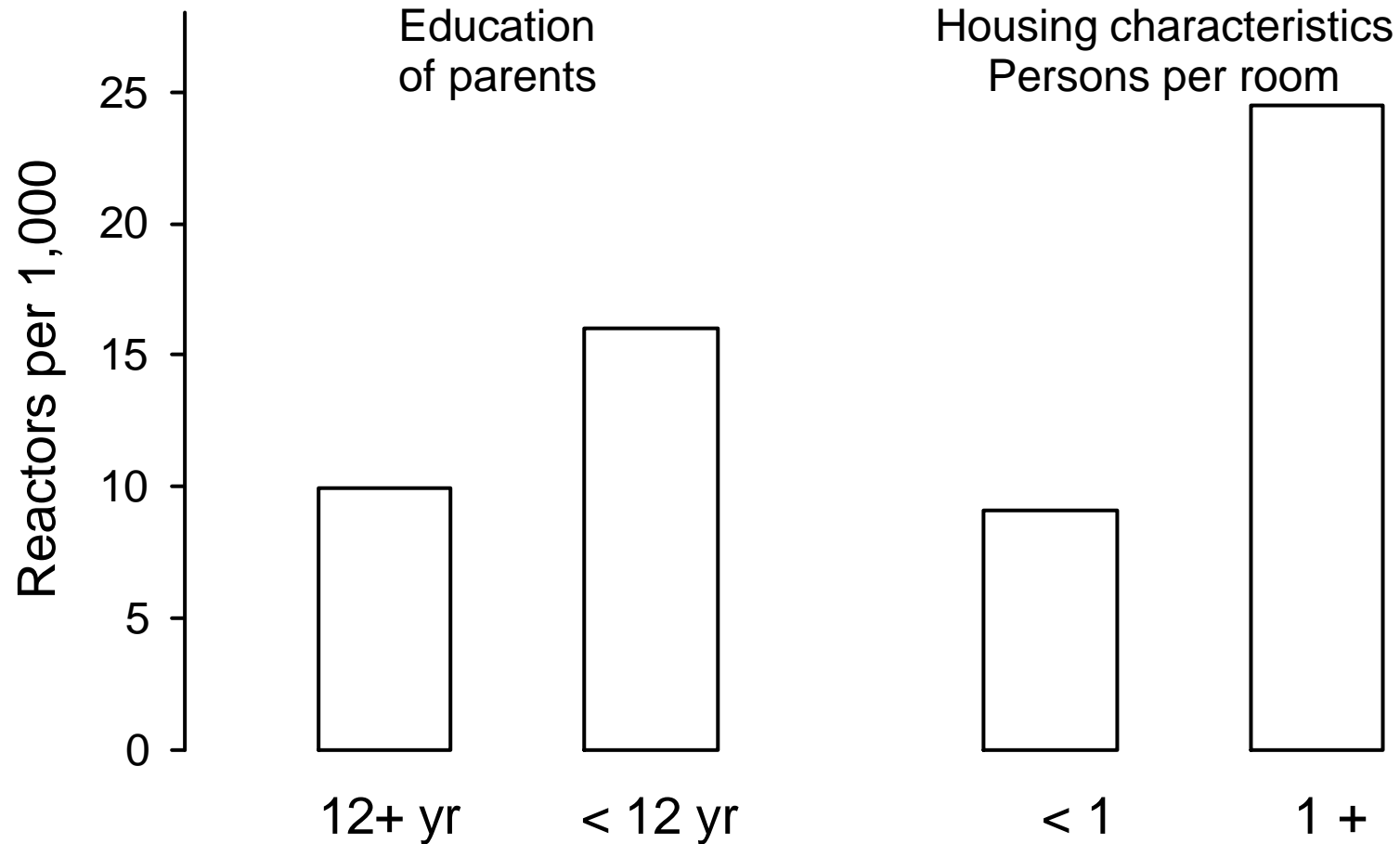

Kuemmerer JM, et al. Am Rev Respir Dis 1967;96:885-92

Secular Trend in Annual Risk of Infection, Selected European Countries

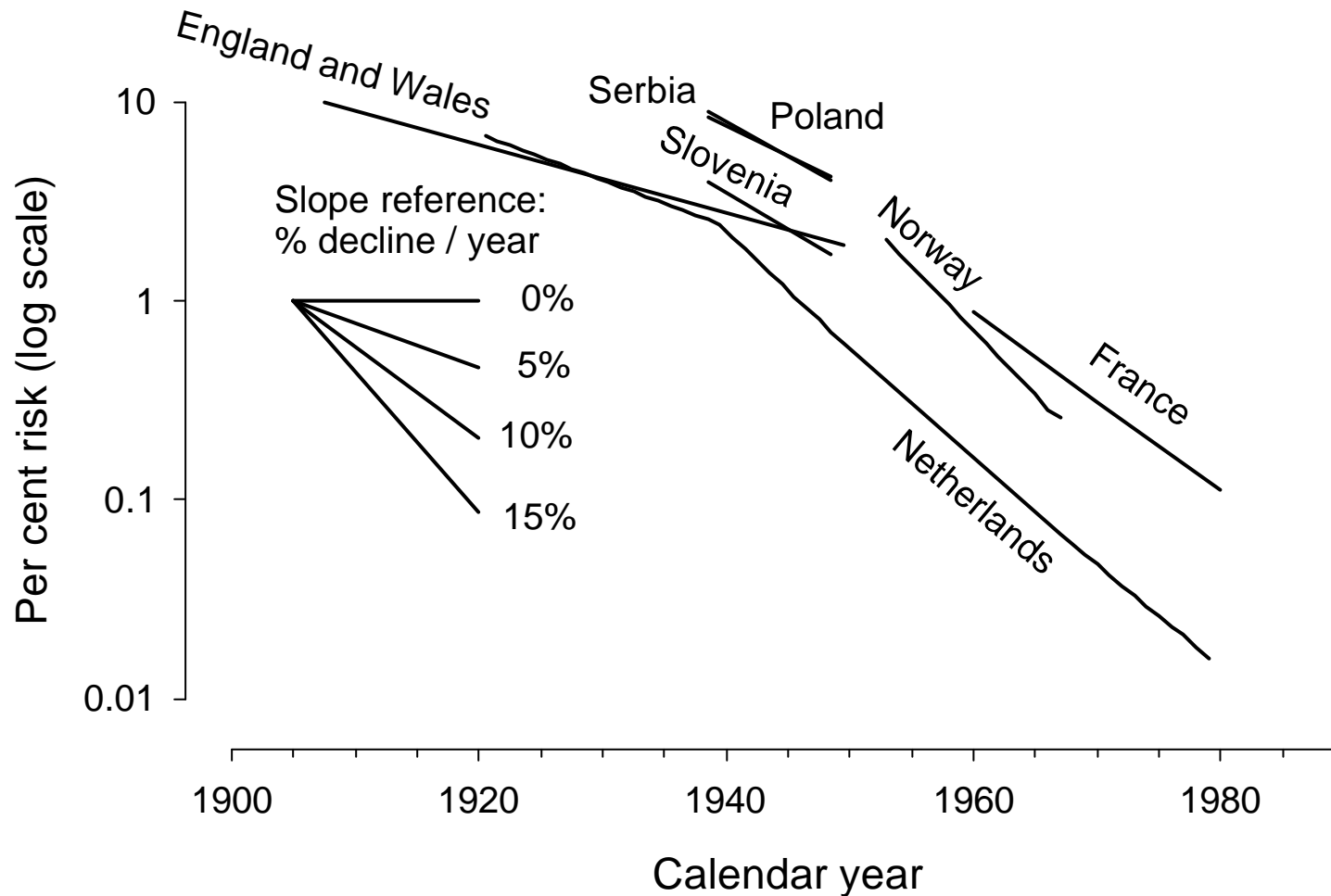

Waalder H, et al. *Bull Int Union Tuberc* 1975;50:5-61
Sutherland I, et al. *Bull Int Union Tuberc* 1971;45:75-114
Lotte A, et al. *Int J Epidemiol* 1973;2:265-82

Sutherland I, et al. *Tubercle* 1983;64:241-253
Styblo K, et al. *Bull Int Union Tuberc* 1969;42:5-104
Vynnycky E, et al. *Int J Tuberc Lung Dis* 1997;1:389-96

Annual Risk of Tuberculous Infection in Low Income Countries of Five WHO Regions

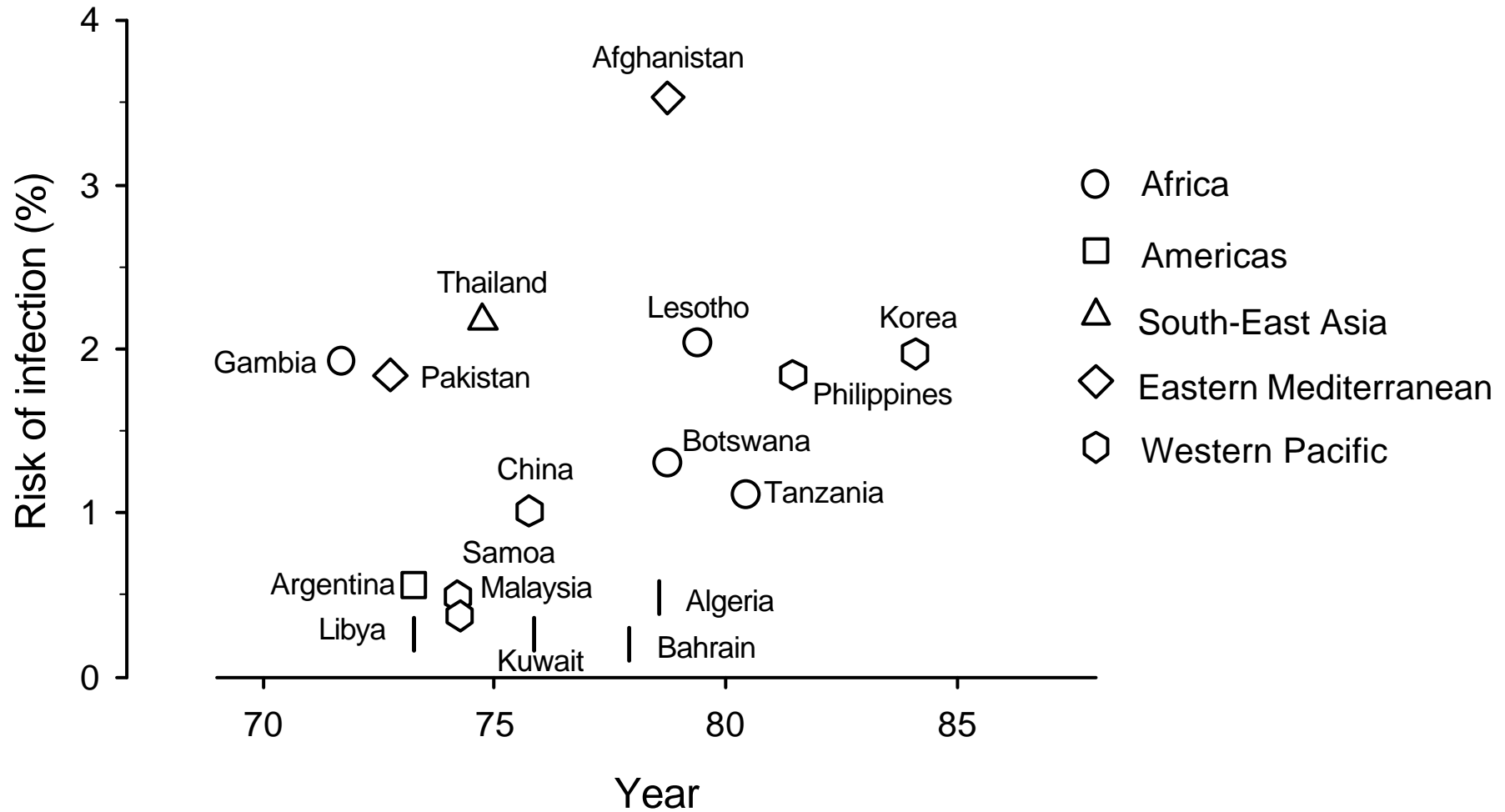

Cauthen GM, et al. WHO Document 1988;WHO/TB/88.154:1-34

Annual Risk of Tuberculous Infection WHO African Region (Except Algeria)

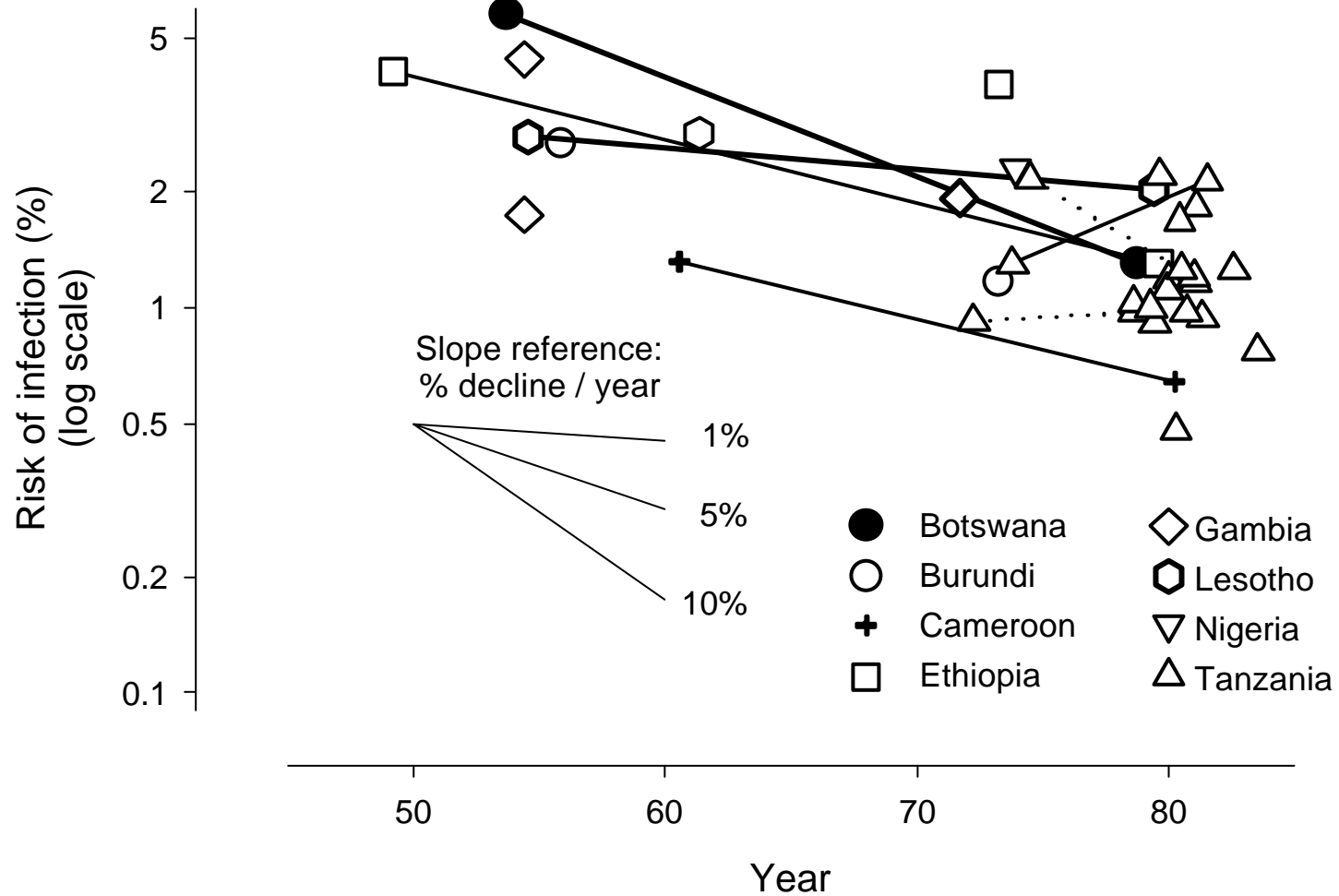

Annual Risk of Tuberculous Infection WHO Eastern Mediterranean Region

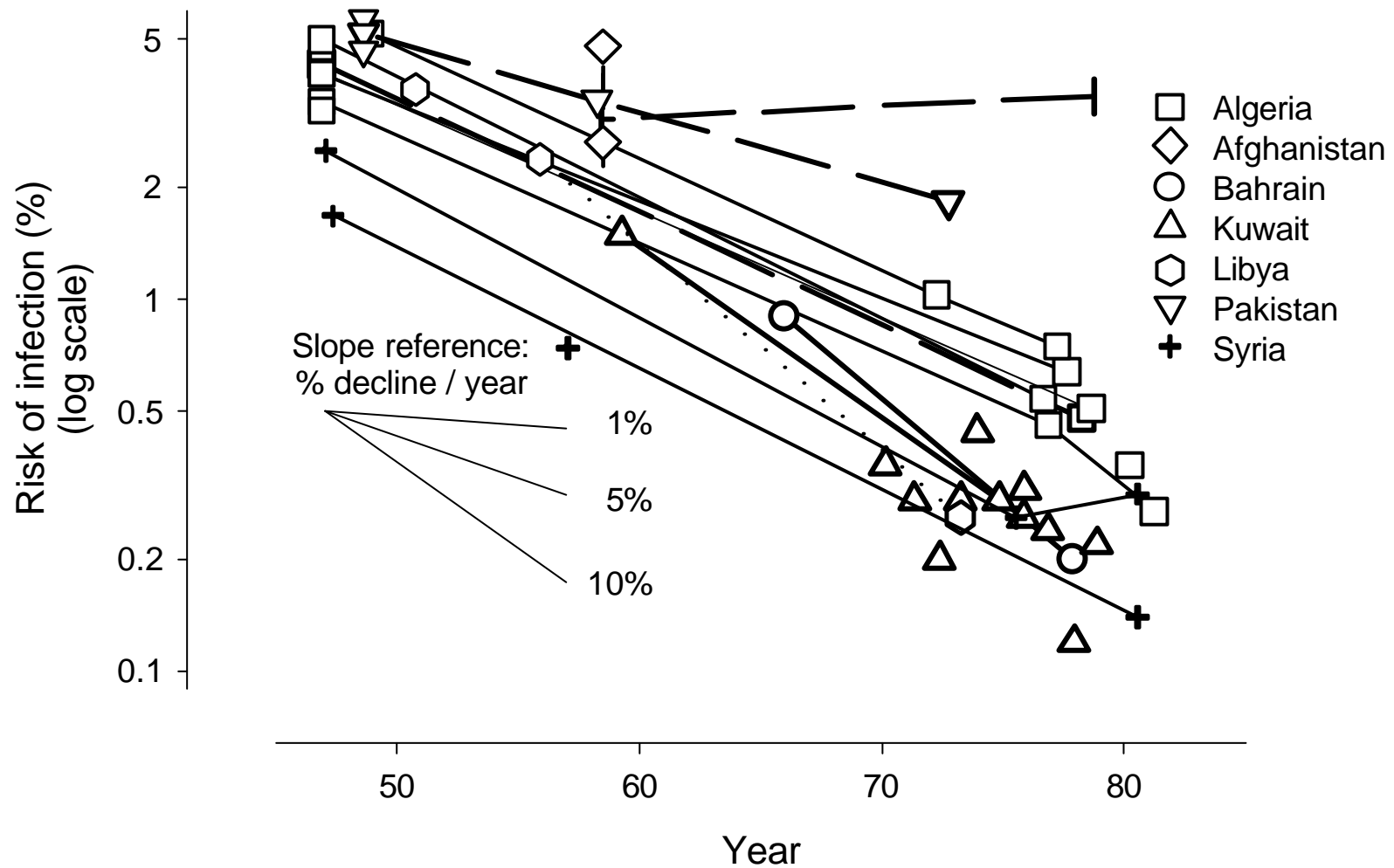

Cauthen GM. WHO Document 1988;WHO/TB/88.154:1-34

Annual Risk of Tuberculous Infection WHO South-East Asia Region

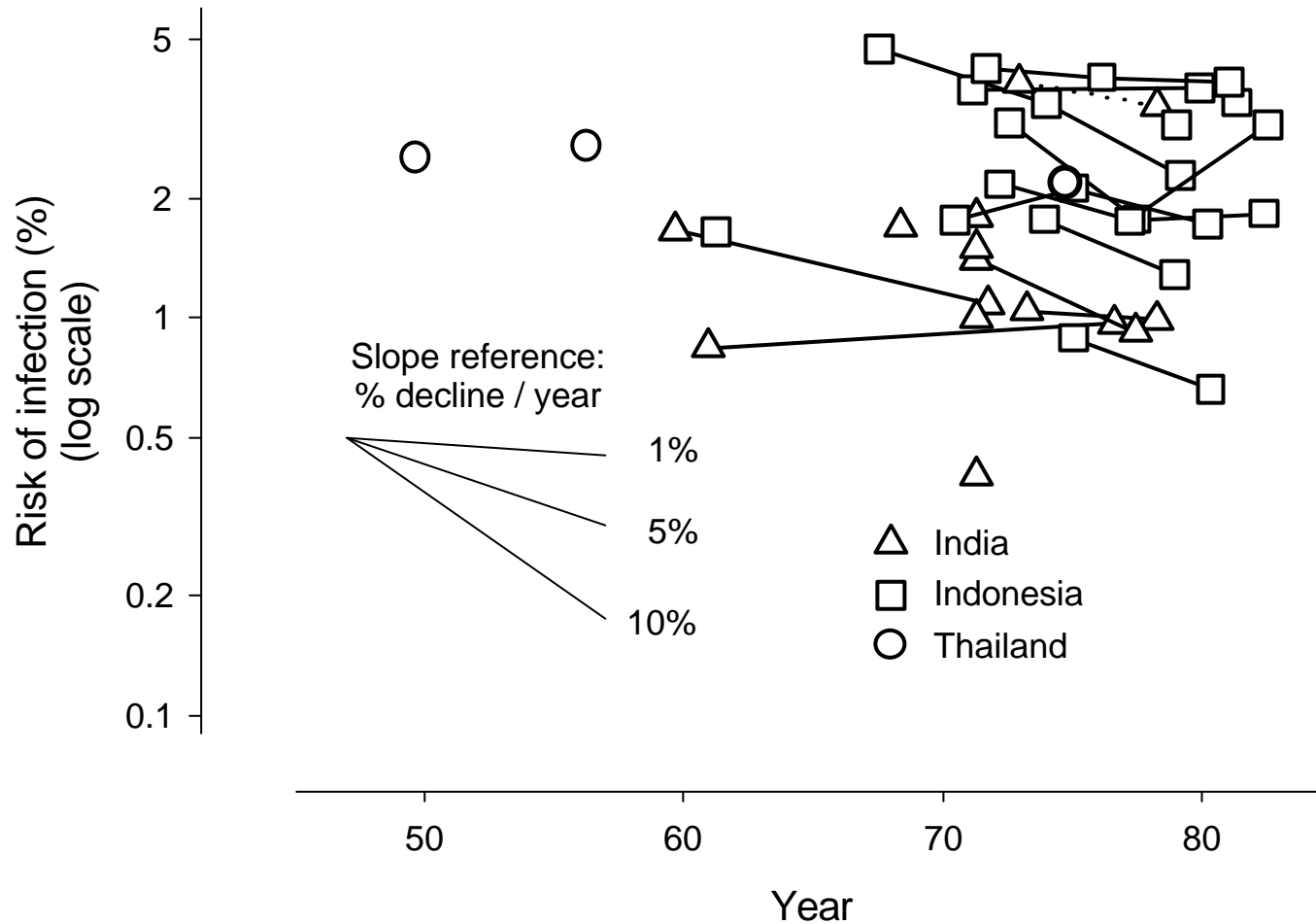

Age-specific Prevalence of Tuberculous Infection in Western Europe

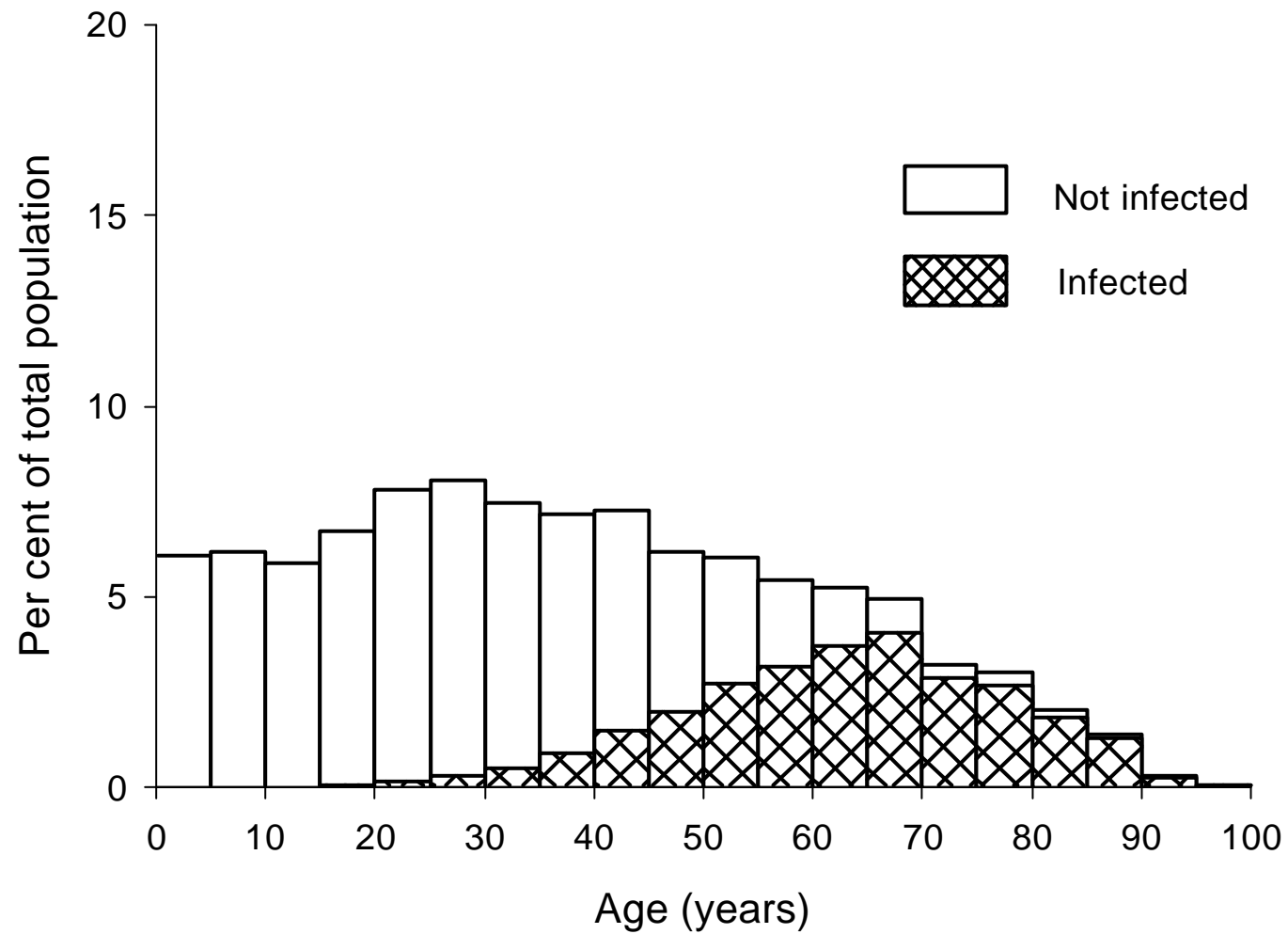

Data courtesy: ten Dam HG, World Health Organization, 1990

Age-specific Prevalence of Tuberculous Infection in Tropical and Southern Africa

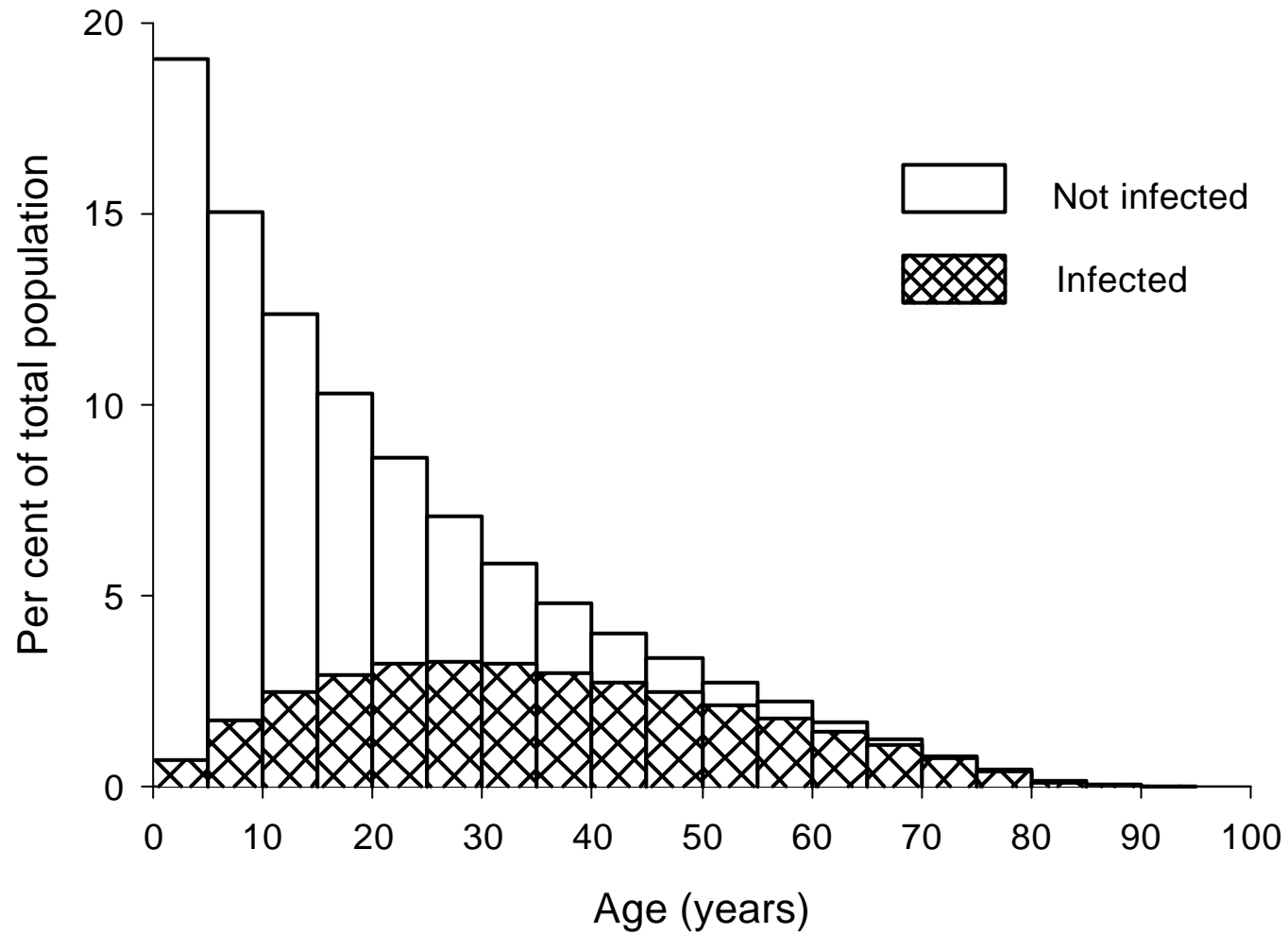

Data courtesy: ten Dam HG, World Health Organization, 1990

Age-specific Prevalence of Tuberculous Infection in South-East Asia and Oceania (Excl. AUS and NZ)



Data courtesy: ten Dam HG, World Health Organization, 1990

Incidence, Point Prevalence, and Period Prevalence

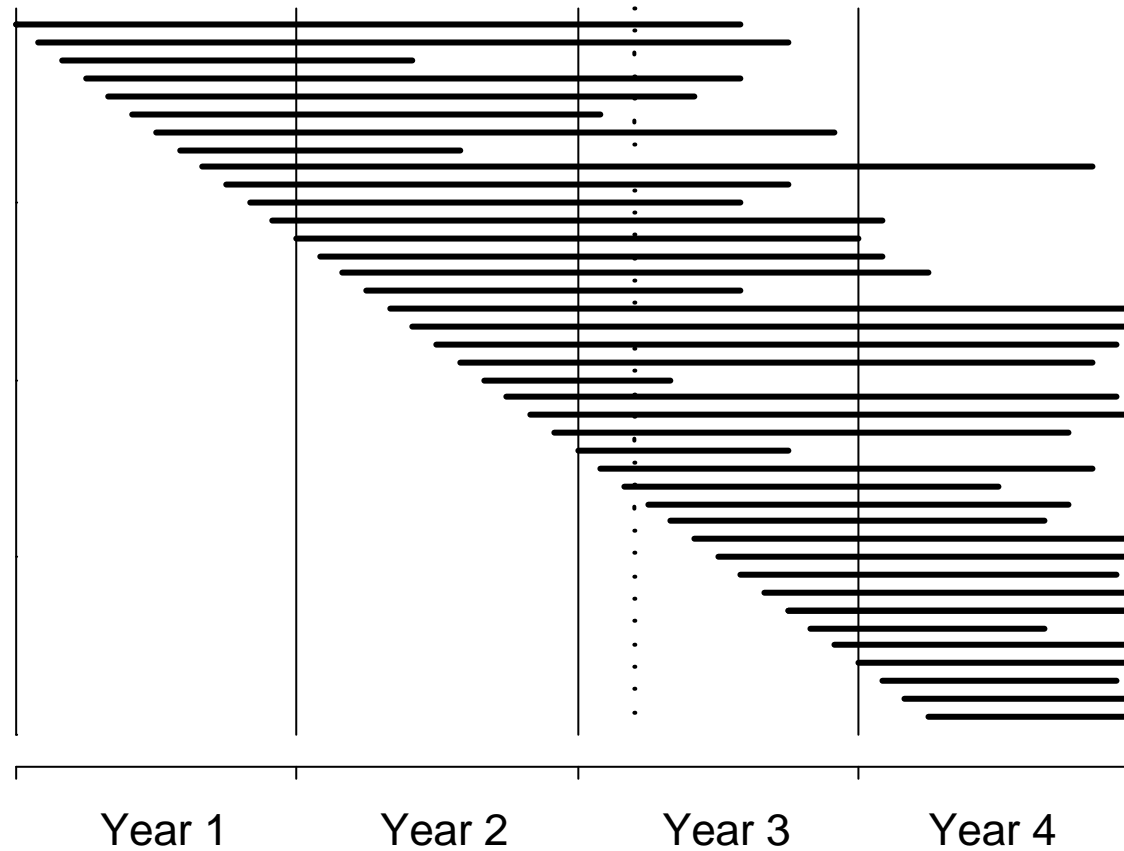

In year 3:

Incidence:	12 cases
Point prevalence, March 15:	24 cases
Period prevalence year 3:	288 person-months

Incidence, Point Prevalence, and Period Prevalence

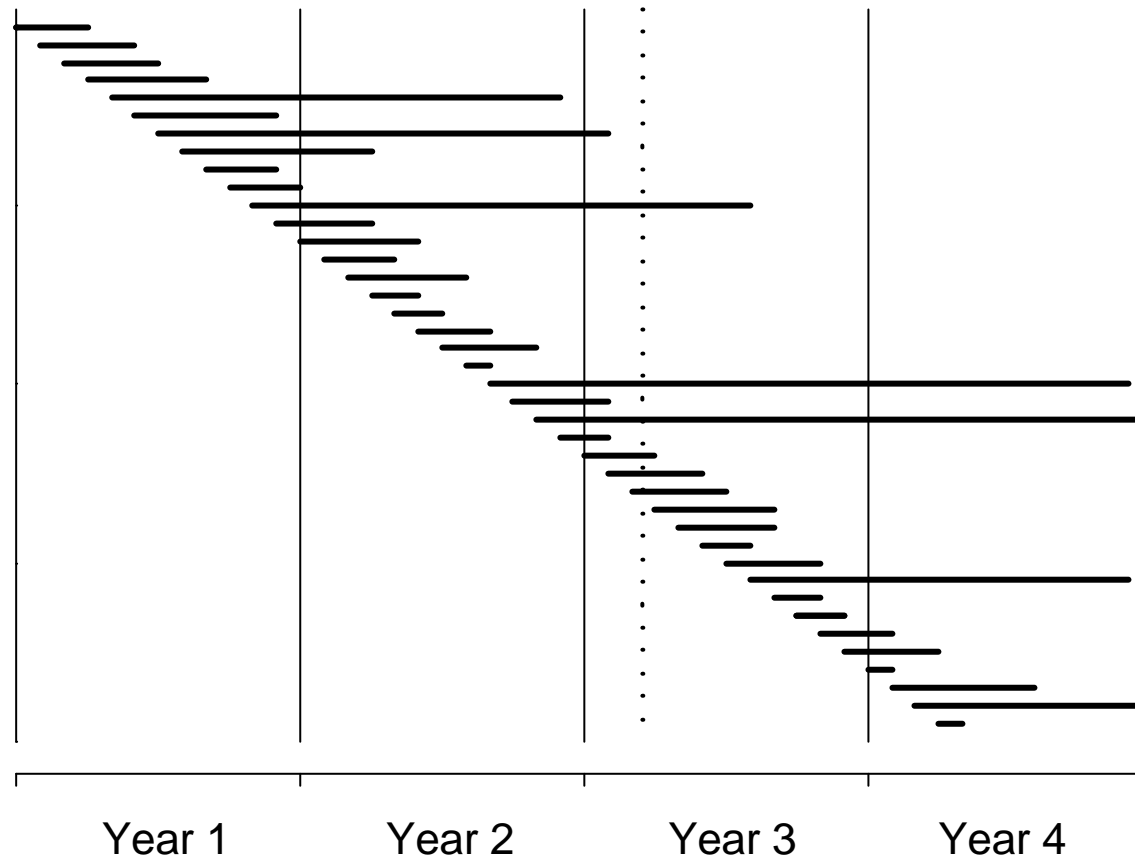

In year 3:

Incidence:	12 cases
Point prevalence, March 15:	6 cases
Period prevalence year 3:	72 person-months

Time After Onset of Symptoms of Pulmonary Tuberculosis Sputum Smears Became Positive for the First Time, Sweden, 1910 and 1934

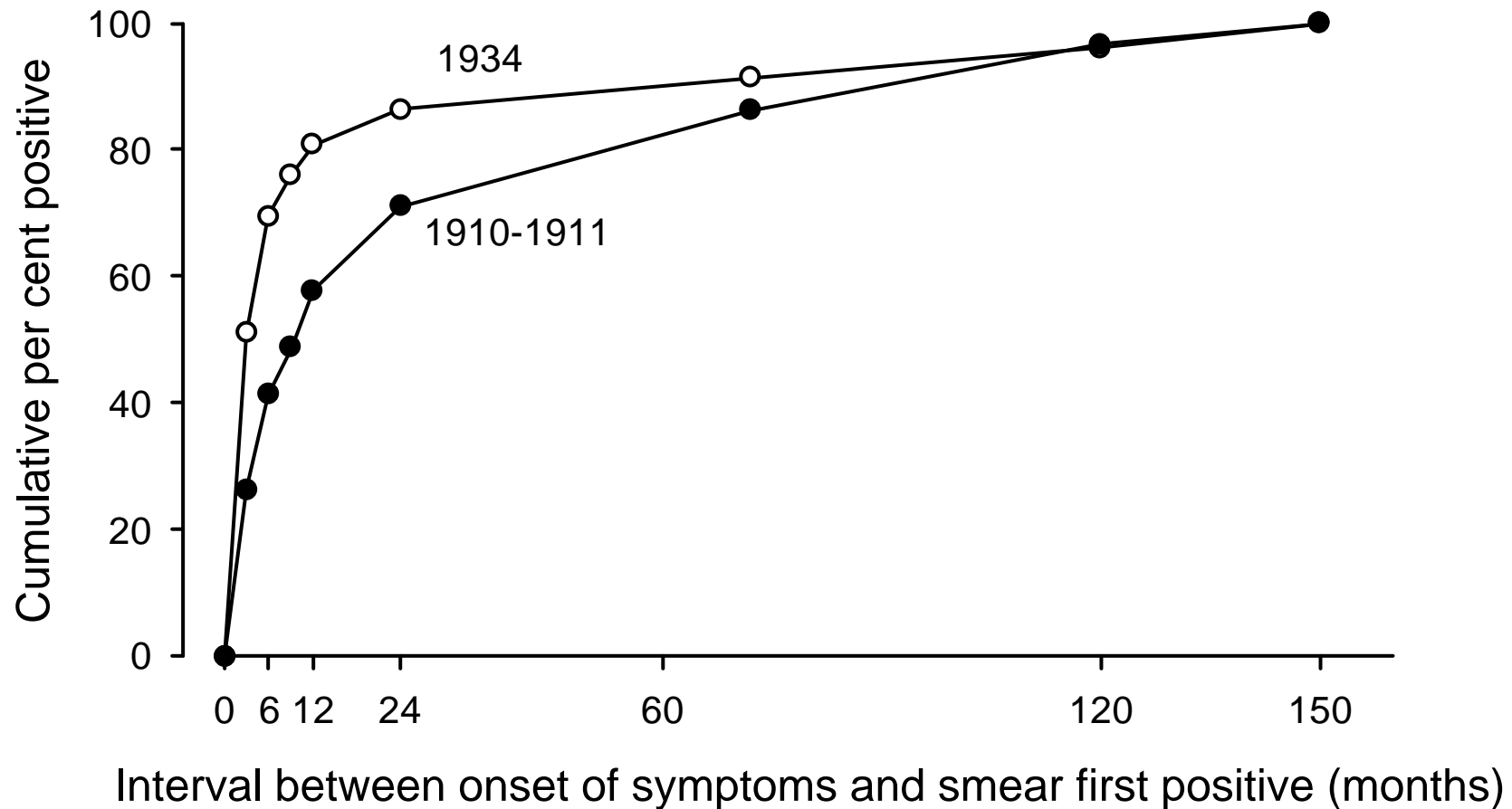

Berg G. In: Ohlson, publisher, Lund, Sweden: 1939:1-207

Selected Risk Factors for Tuberculosis Given that Tuberculous Infection has Occurred

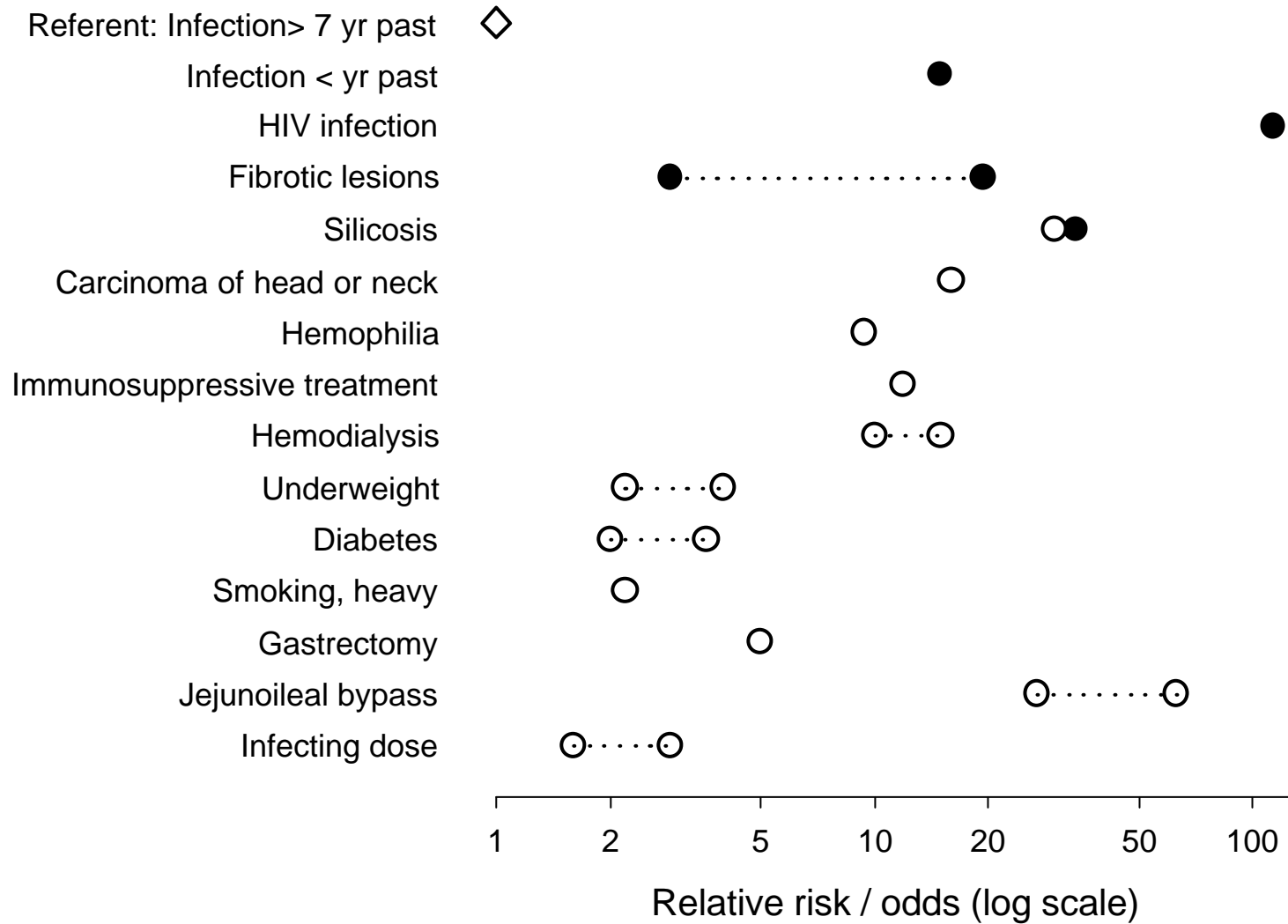

Interval Between Infection and Manifestation of Primary Tuberculosis

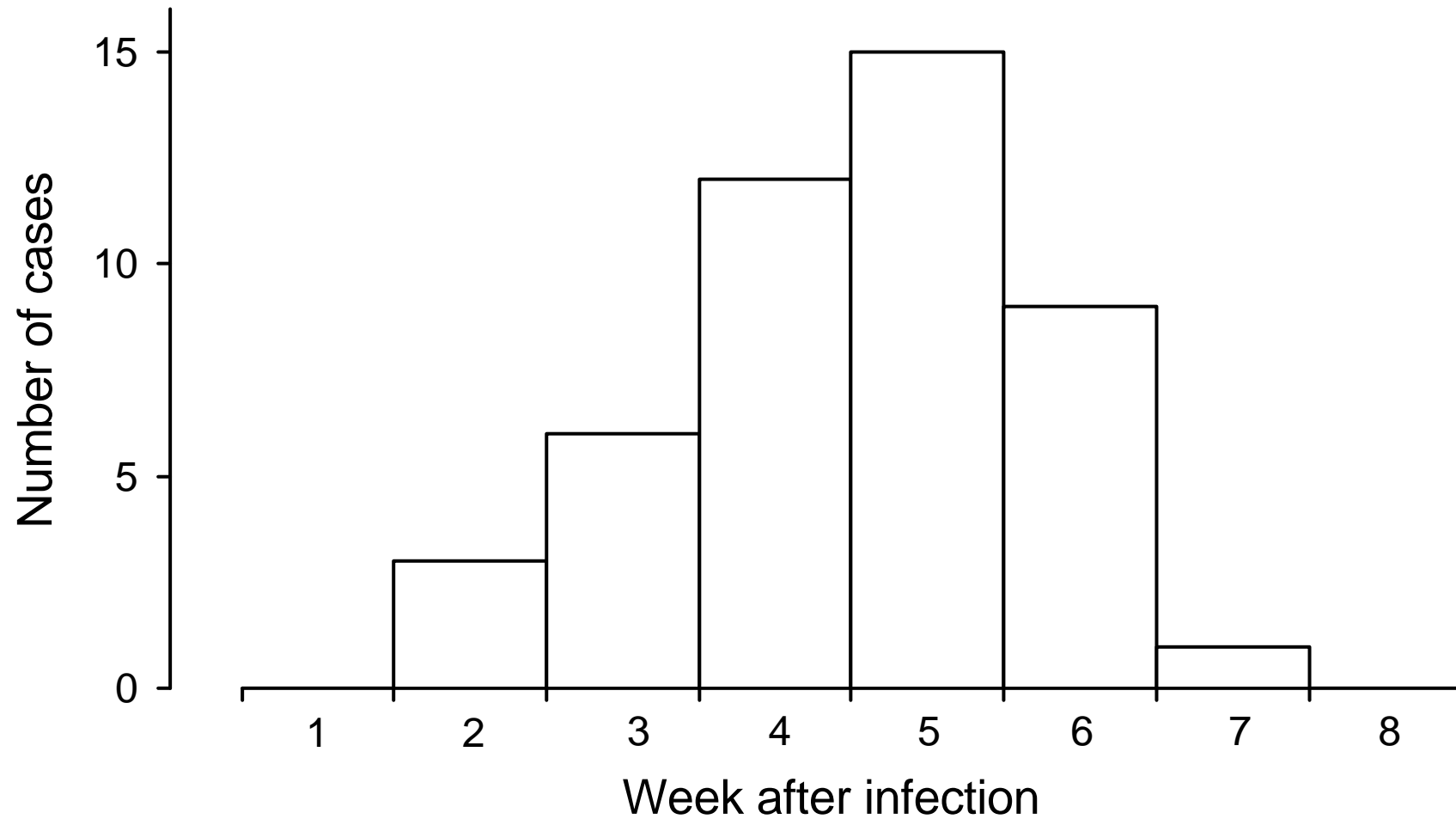

Wallgren A. Tubercle 1948;29:245-51

Interval Between Infection and Manifestation of Tuberculous Meningitis

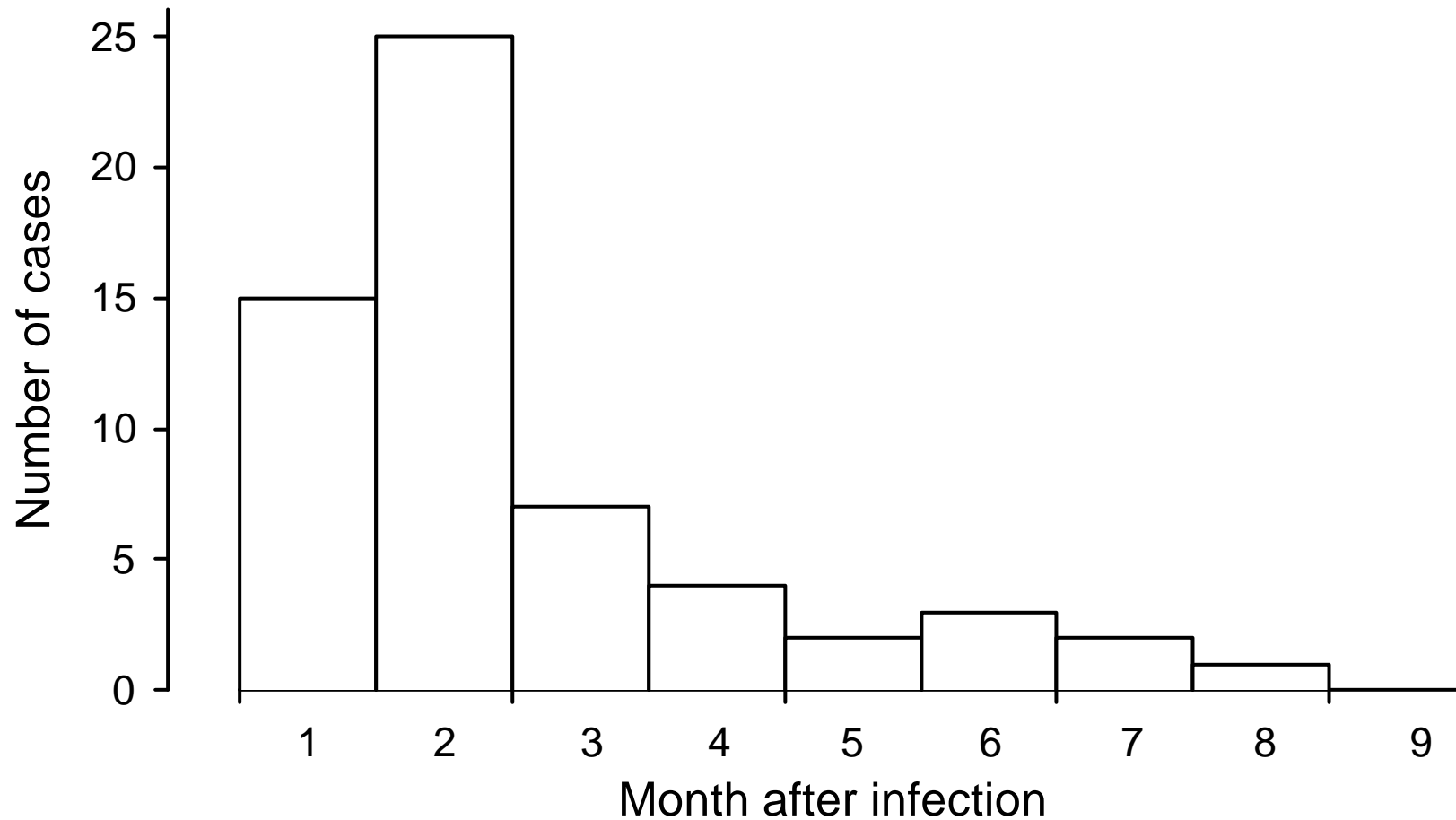

Wallgren A. Tubercle 1948;29:245-51

Incidence of Tuberculosis During Follow-up in the Placebo Groups of Preventive Chemotherapy and BCG Trials

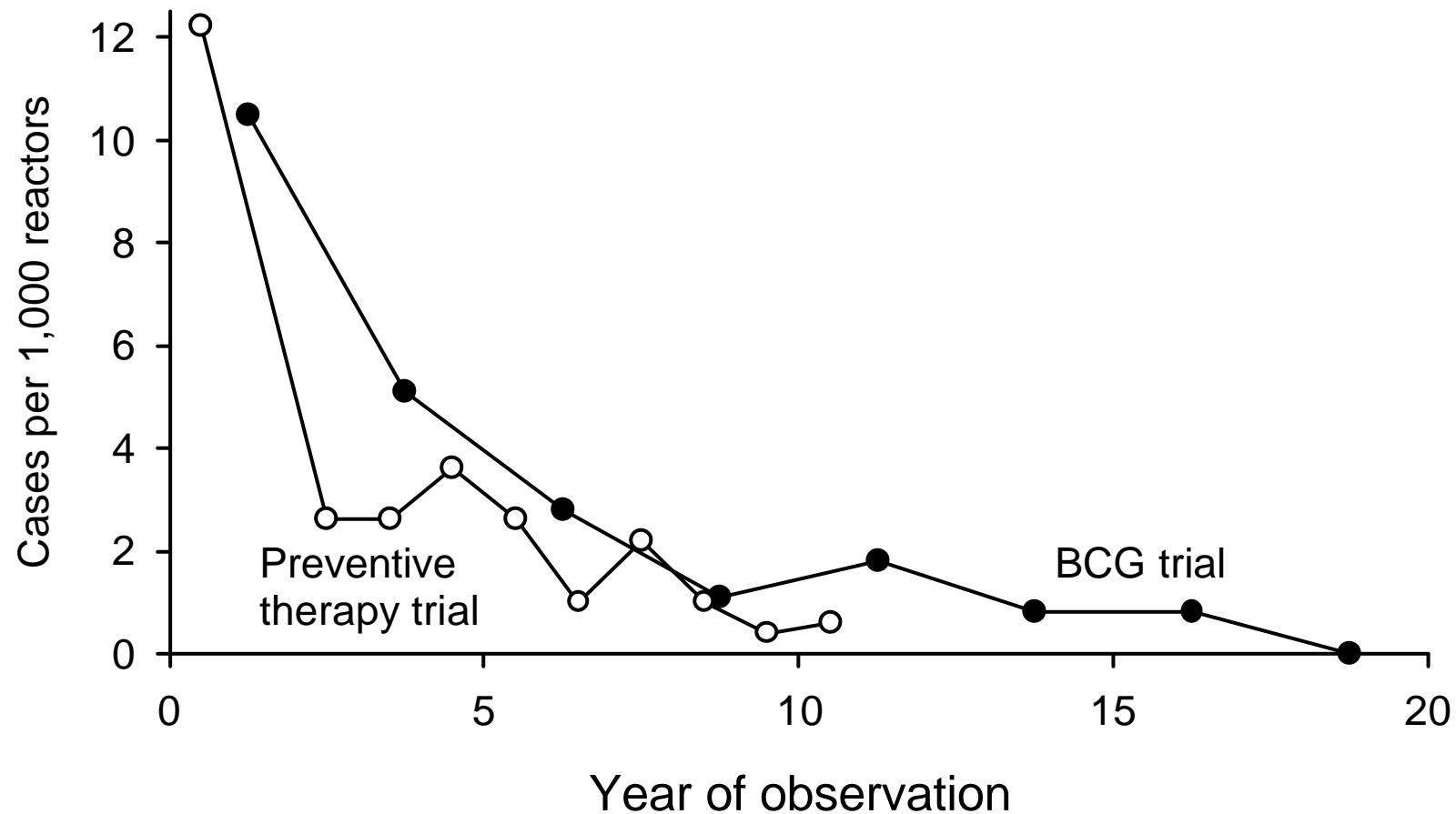

Ferebee SH. Adv Tuberc Res 1969;17:28-106

D'Arcy Hart P, et al. Br Med J 1977;2:293-5

Interval Between Report of Tuberculosis and Diagnosis of AIDS, Florida, United States, 1981 - 1986

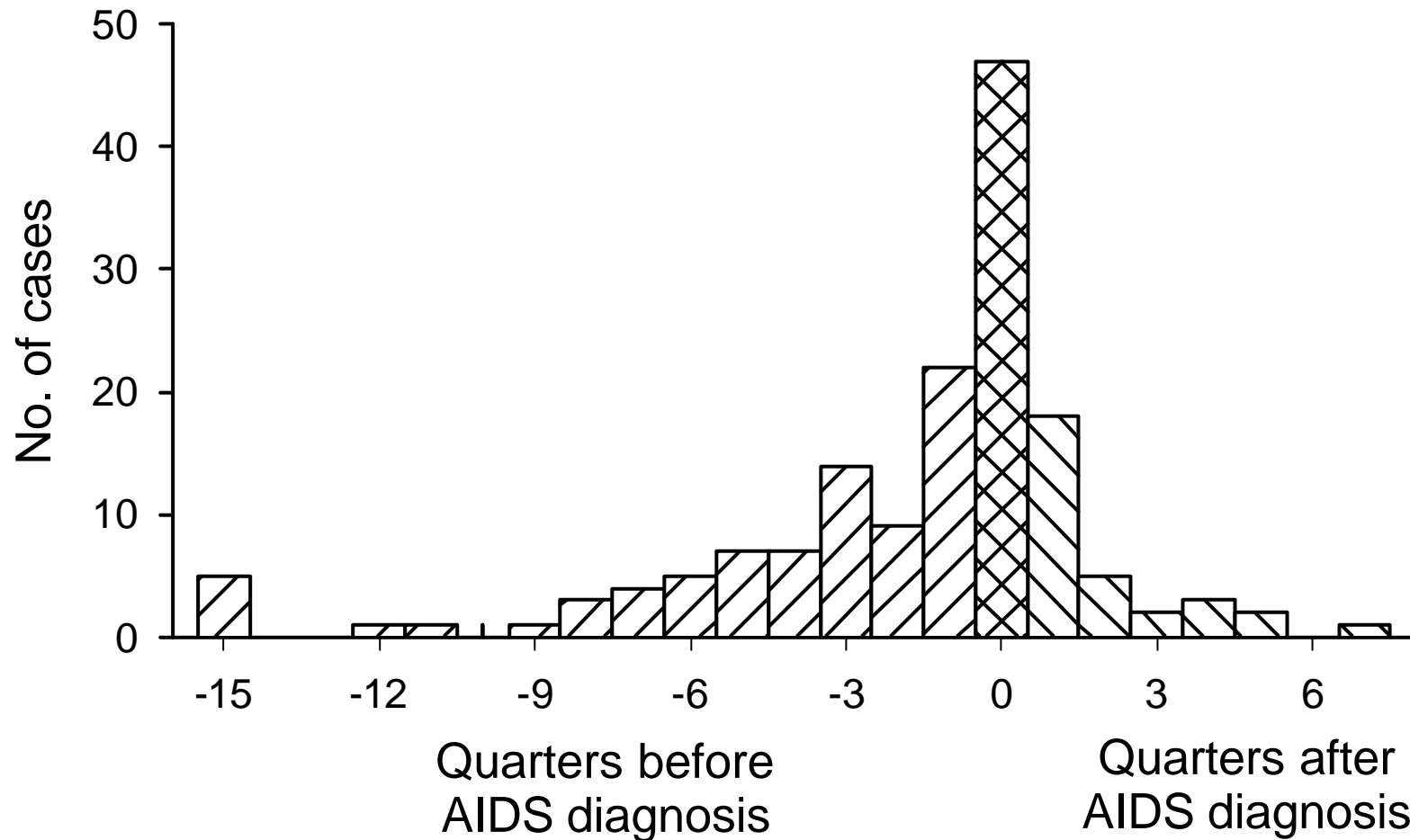

Risk of Tuberculosis Among HIV Infected, Tuberculin-Positive Persons, by CD4⁺ Lymphocyte Count

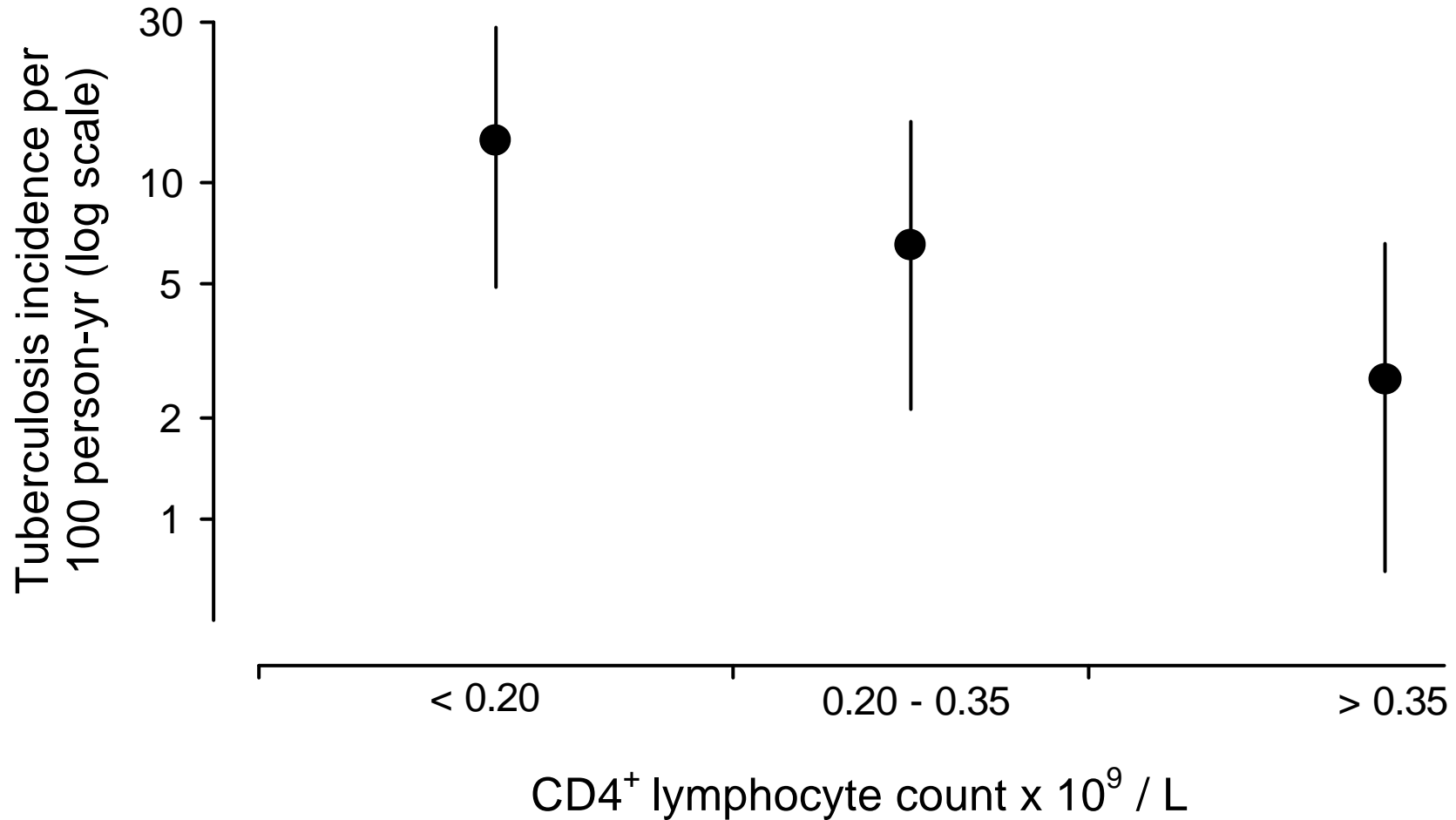

Antonucci G, et al. J Am Med Assoc 1995;274:143-8

Correlation Between Extent of HIV-Induced Immuno-Suppression and Clinical Manifestation of Tuberculosis

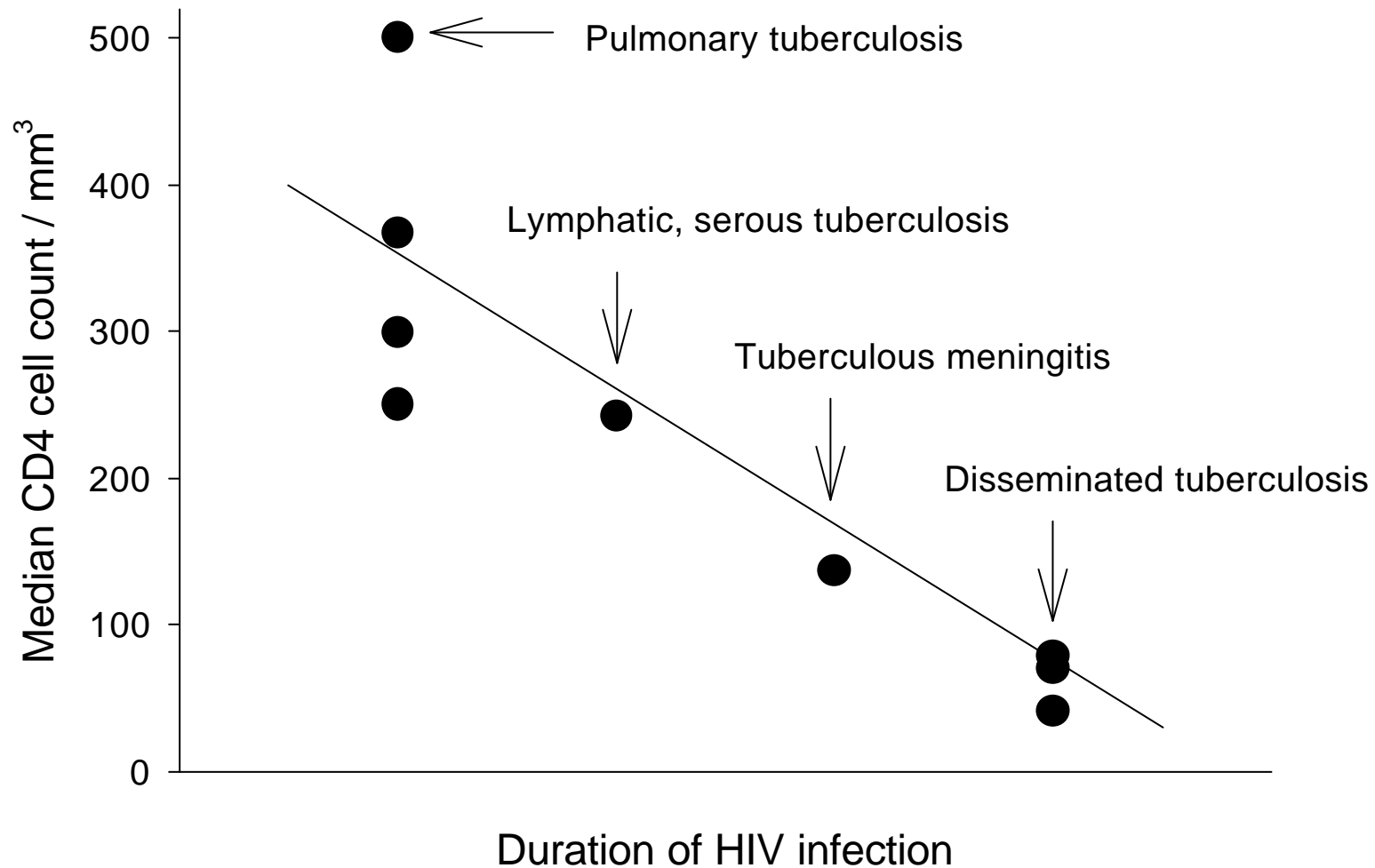

De Cock KM, et al. J Am Med Assoc 1992;268:1581-7

Tuberculosis Risk Among HIV Infected Persons, by Size of Tuberculin Skin Test Result, Italy

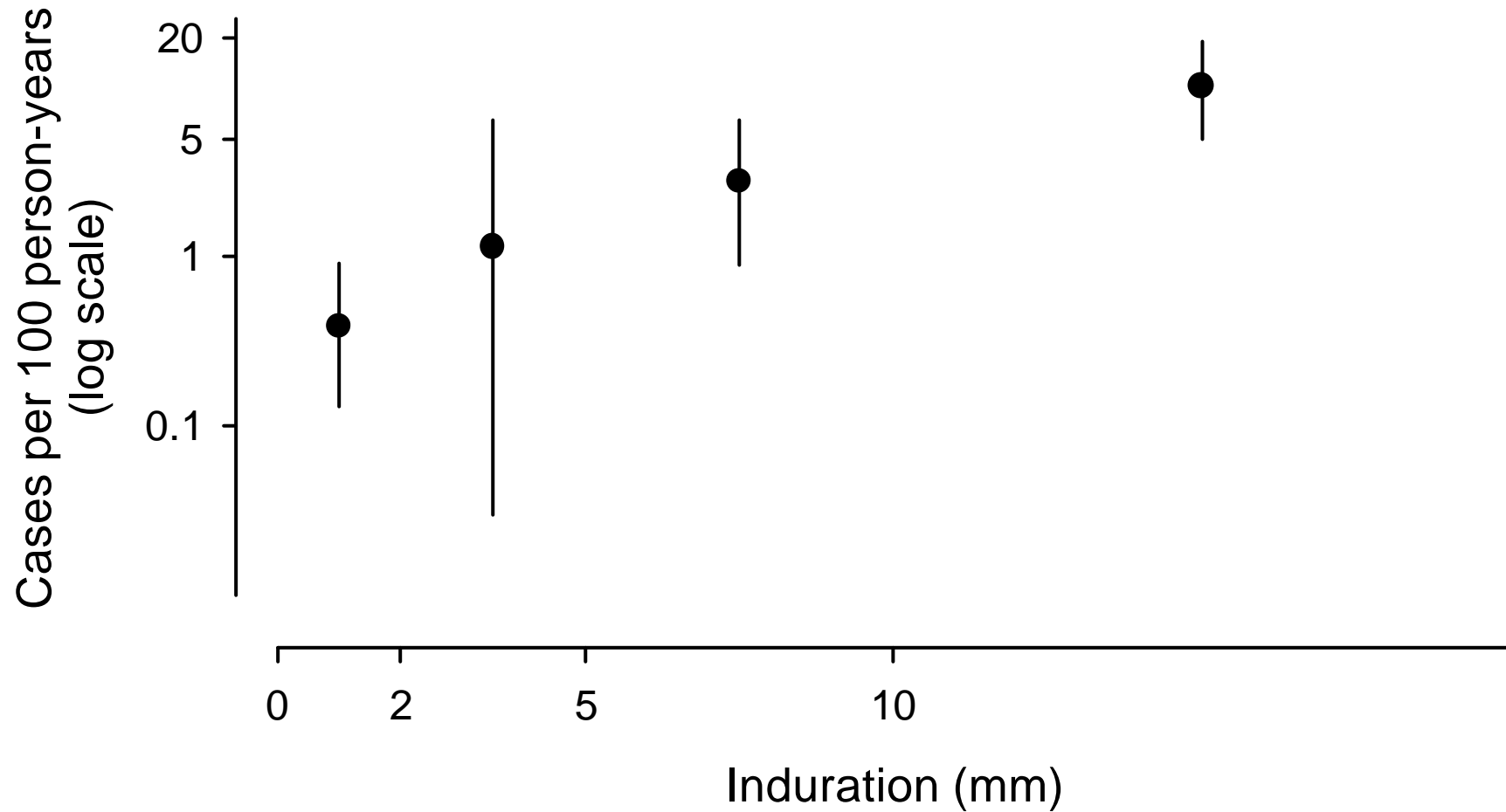

Girardi E, et al. Arch Intern Med 1997;157:797-800

Example of Risk Differences in Individuals Following Infection with *M. tuberculosis*

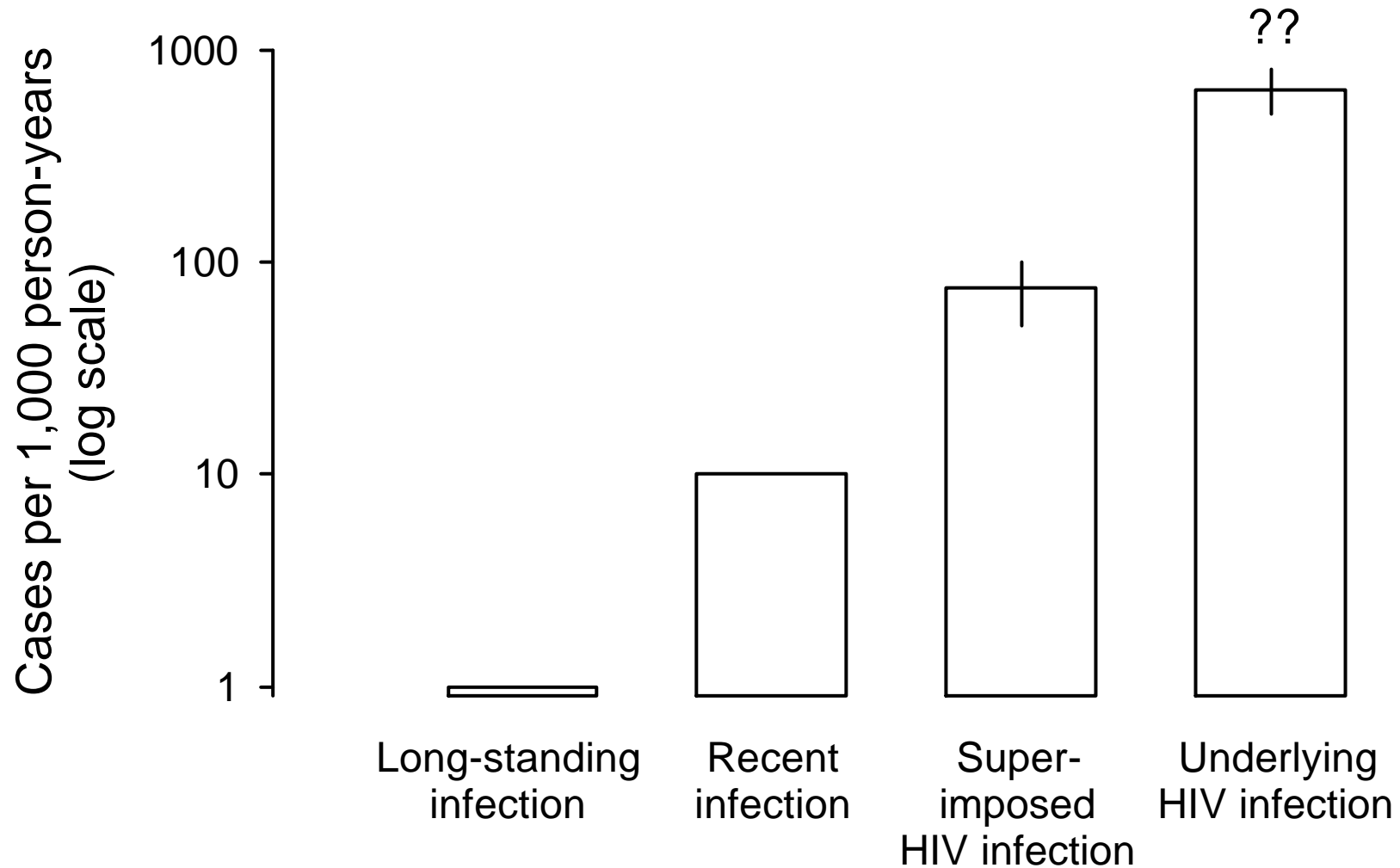

Incidence of Tuberculosis Among Initial Reactors, by Age when Tuberculosis was First Diagnosed

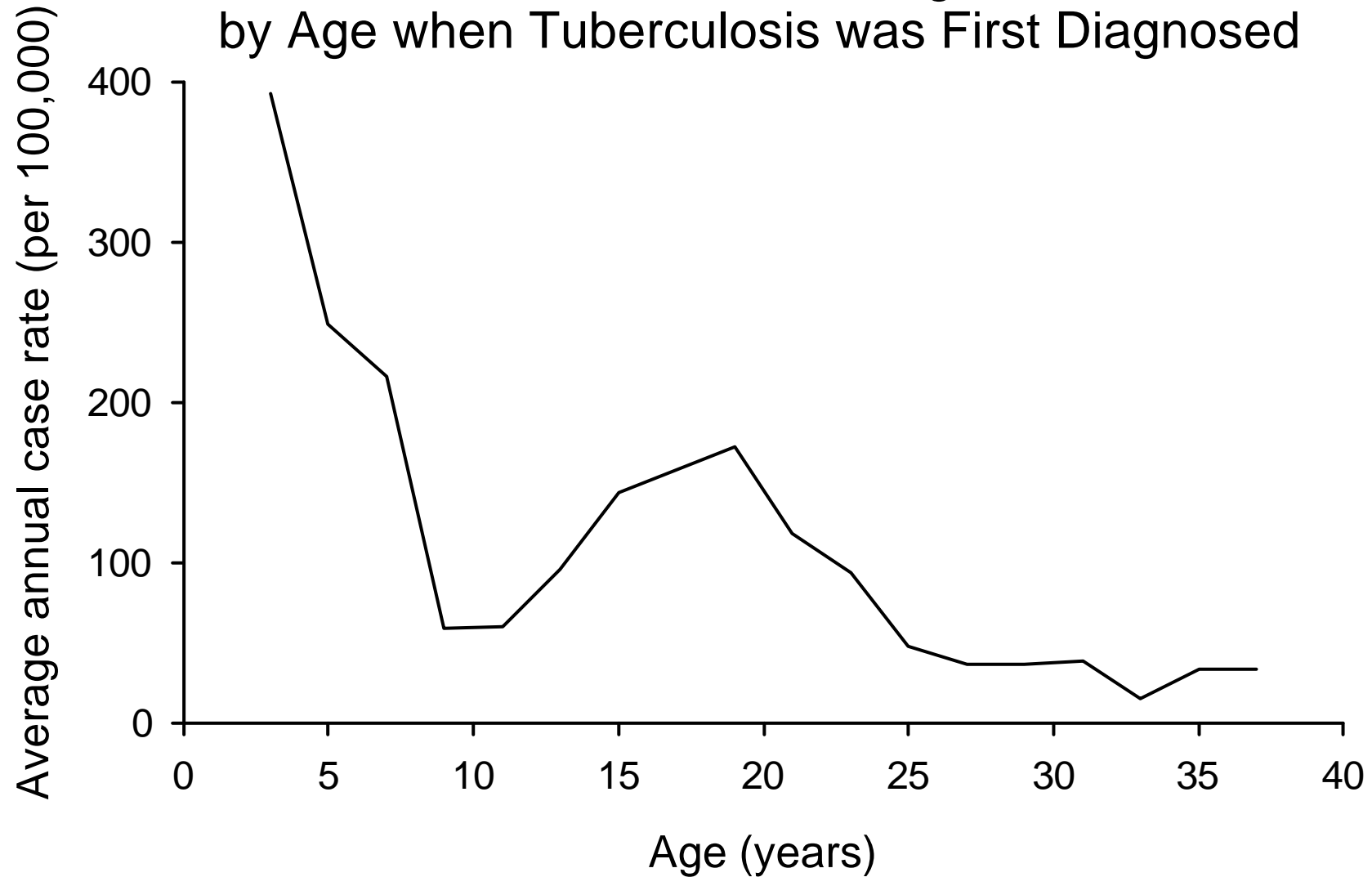

Comstock GW, et al. Am J Epidemiol 1974;99:131-8

Tuberculosis of Peripheral Lymph Nodes by Age and Sex, Cambodian Refugees, Thailand 1981 - 1984

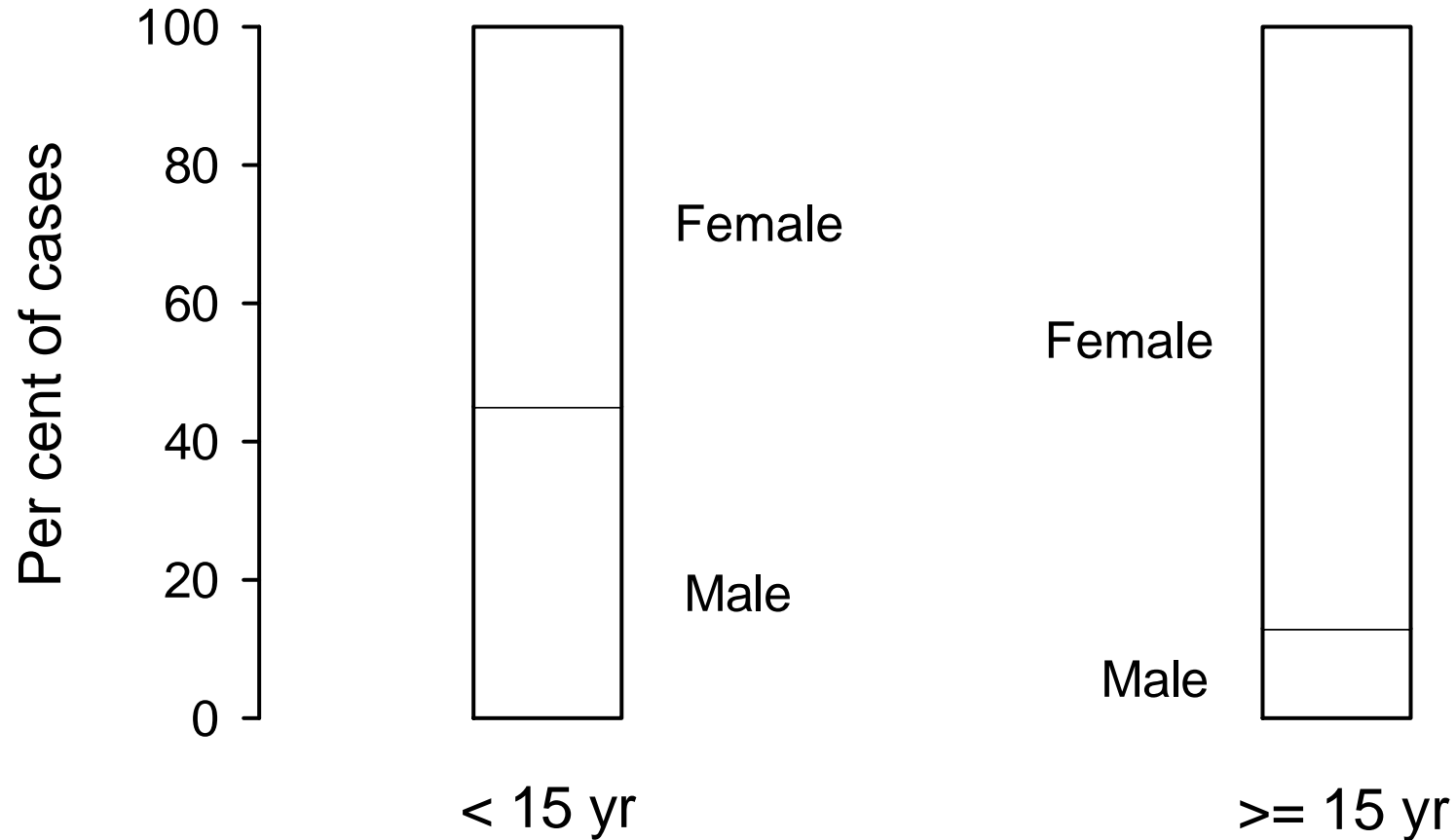

Incidence of Infectious Tuberculosis by (Age-Adjusted) Body Mass Index, 15+ Years Old, by Sex, Norway, 1963 - 1975

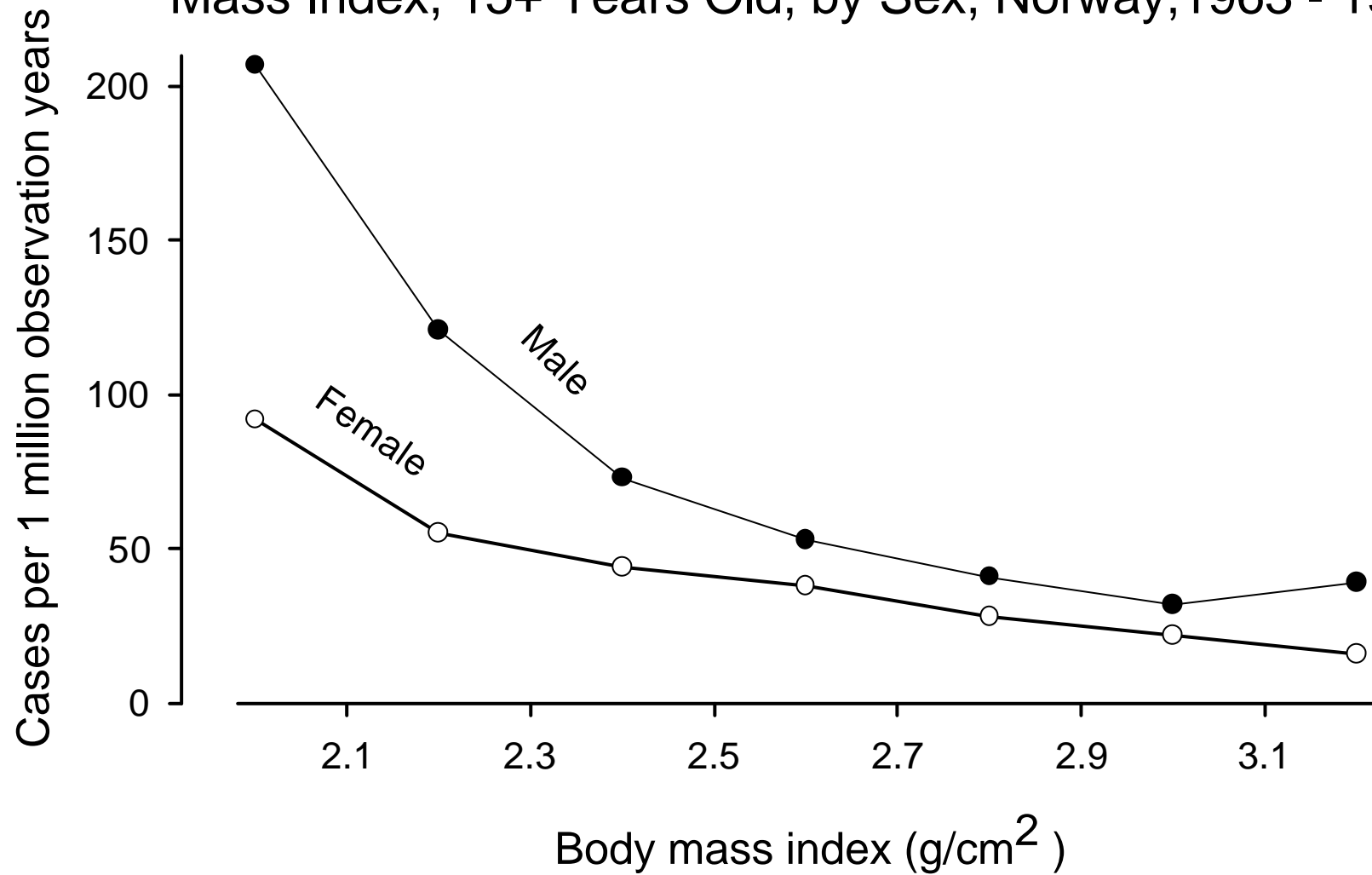

Tverdal A. Eur J Respir Dis 1986;69:355-62

Lupus vulgaris in a German Family, 1920ies

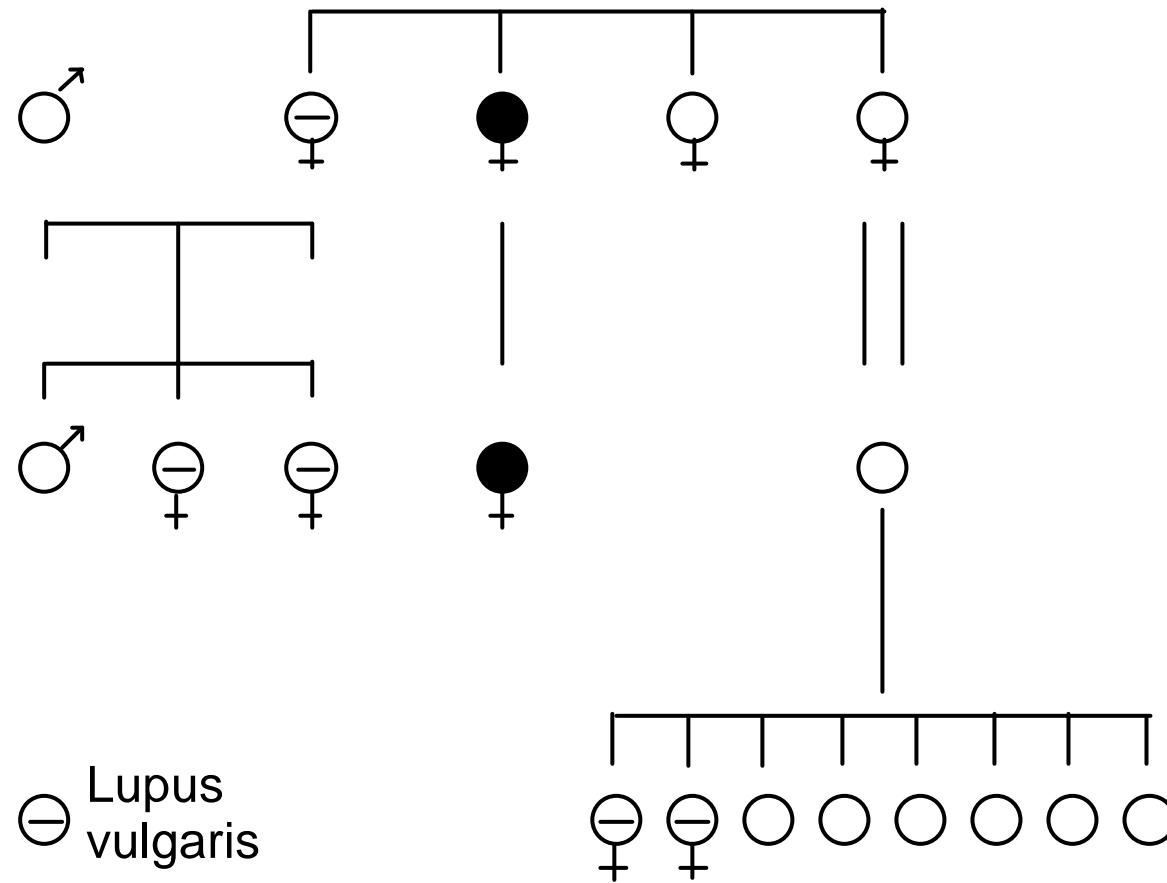

Berghaus W. Zeitschrift Hyg 1936;117:757-67

Relative Odds for Tuberculosis Among Male Smokers, Aged 30 Years and Older, Great Britain

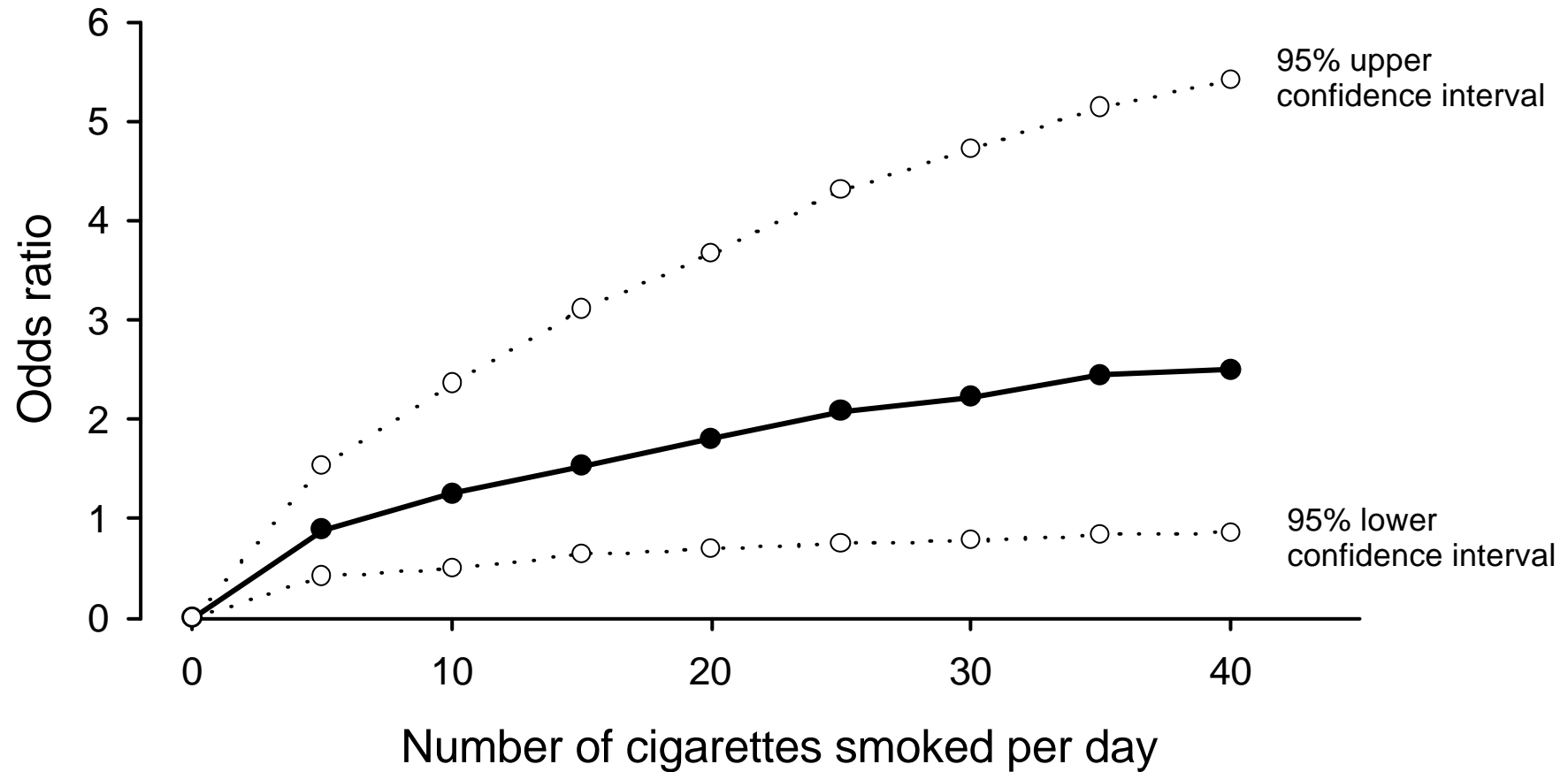

Edwards JH. Br J Prev Soc Med 1957;11:10-11

Cumulative Percentage Tuberculosis-Free by Category of Silicosis Among Gold Miners, South Africa

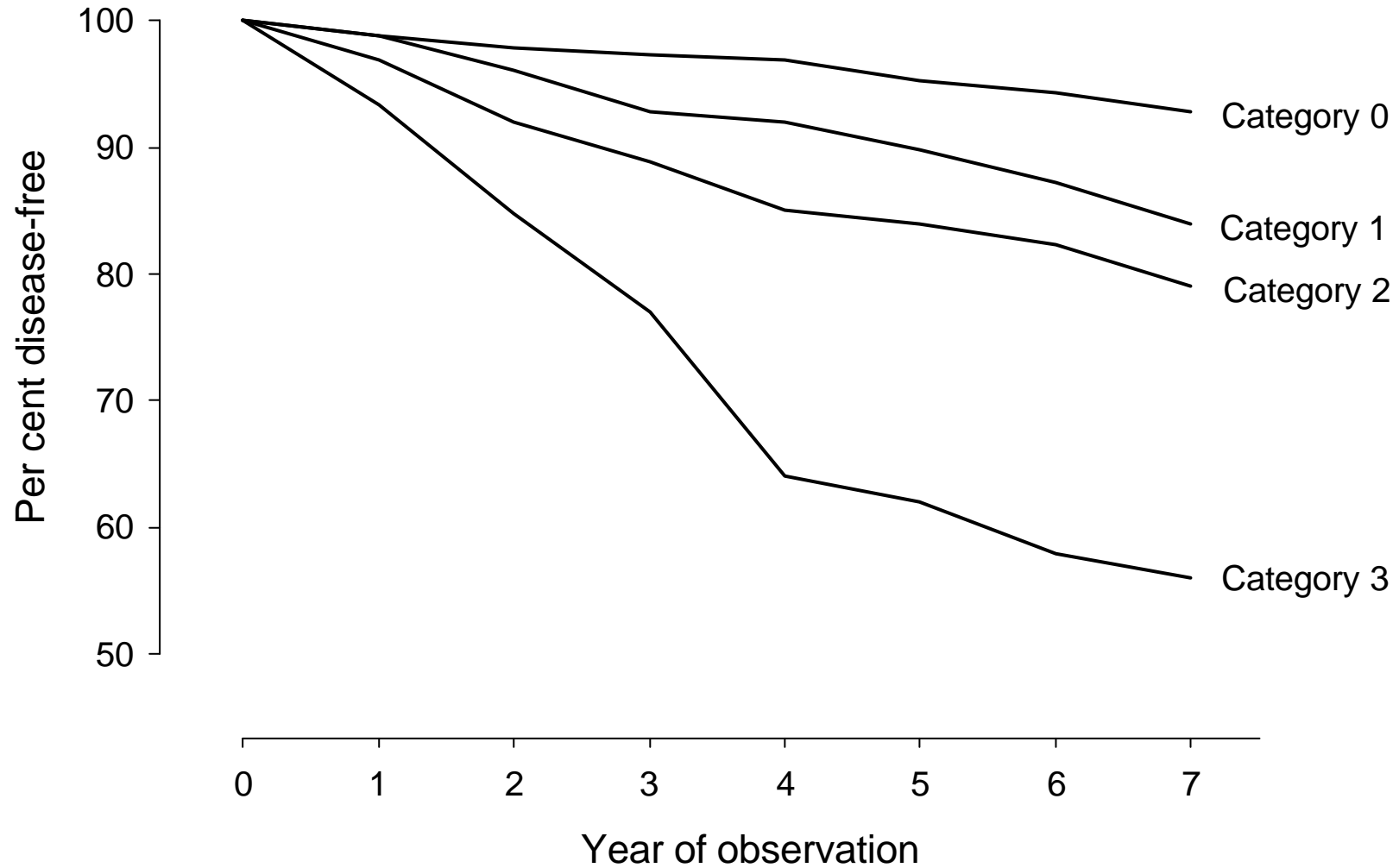

Percentage of Secondary Cases Among Tuberculin-Positive Contacts, by Type of Source Case, Canada, 1966 - 1971

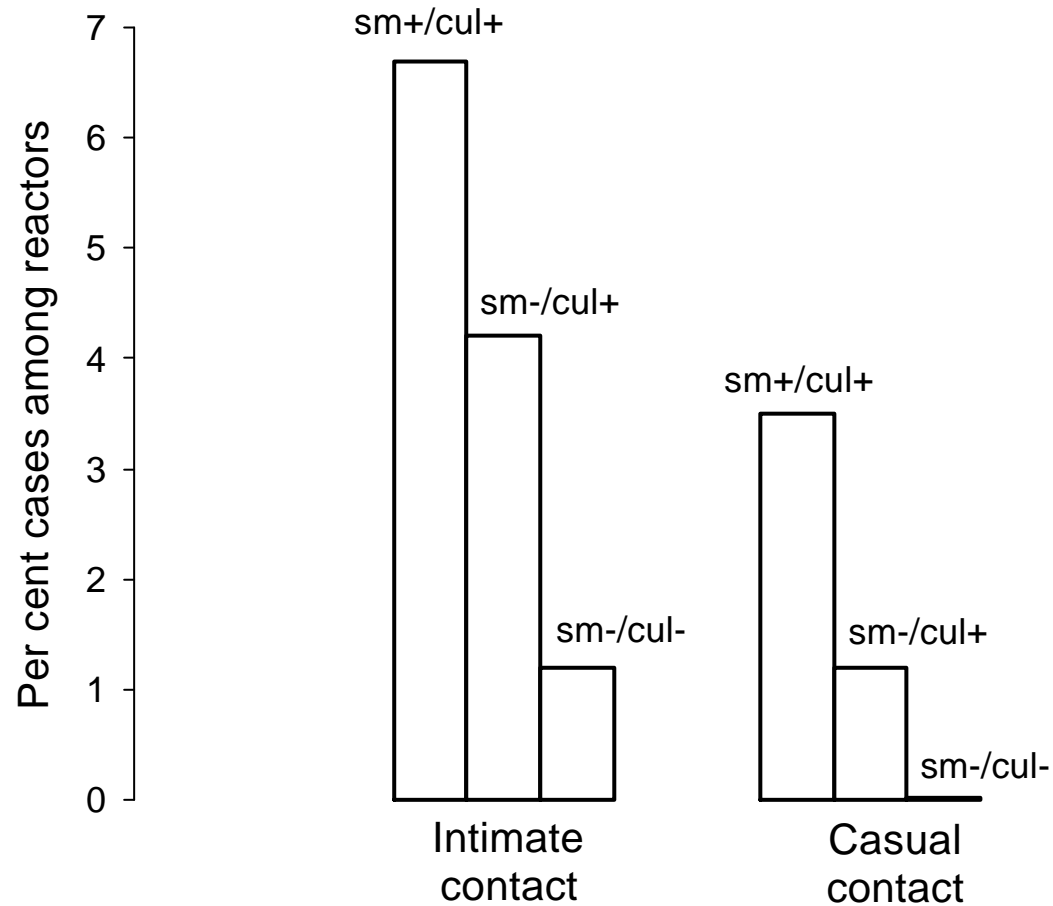

Grzybowski S, et al. *Bull Int Union Tuberc* 1975;50:90-106

Rieder HL, et al. *Epidemiol Rev* 1989;11:79-98

Correlation Between Tuberculous Herds (1937 - 1939) and Human Morbidity per 1,000 Skin Test Reactors (1950 - 1952), Denmark

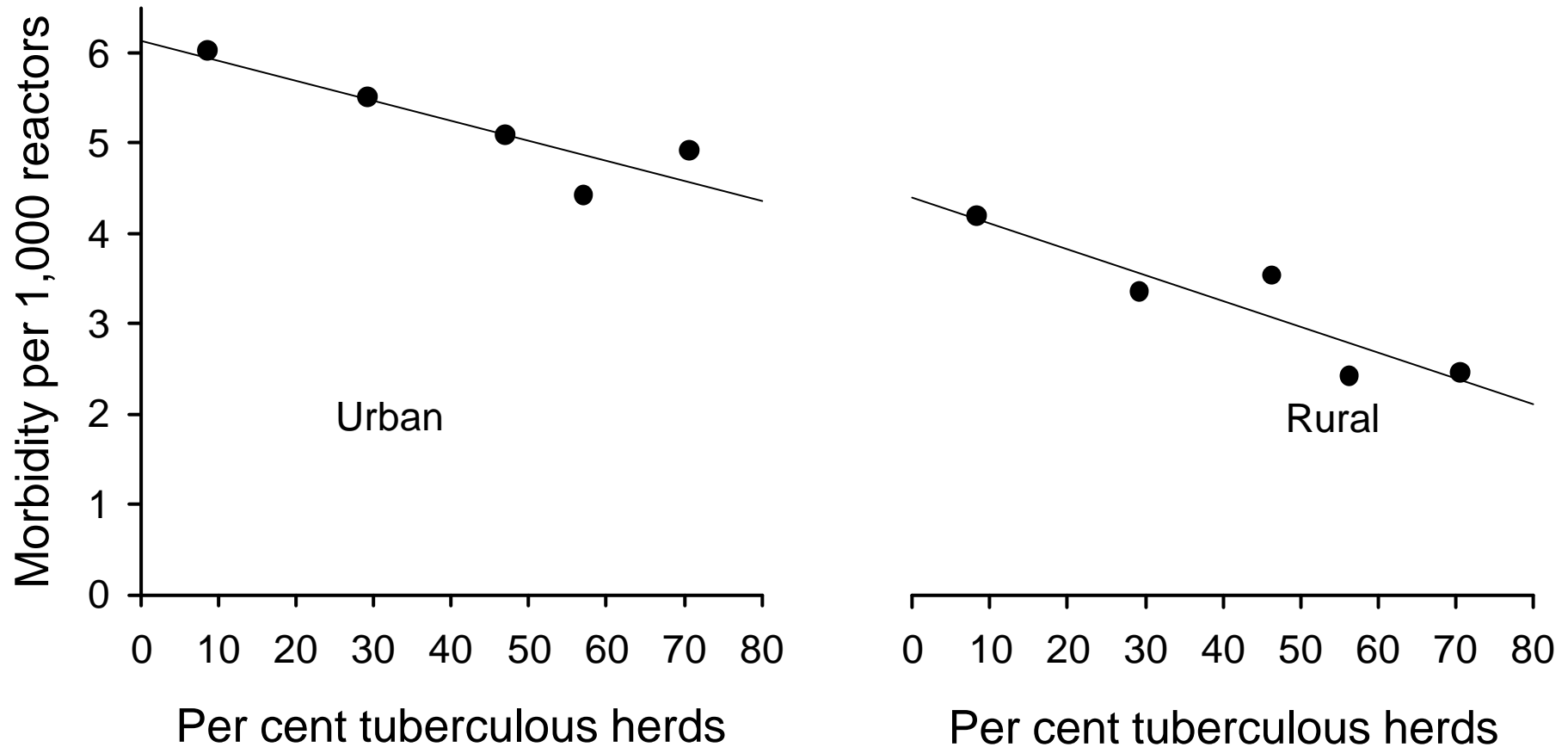

Magnus K. *Bull World Health Organ* 1966;35:483-508

Estimated Morbidity Rates Following Infection with *M. bovis* or *M. tuberculosis*, Denmark

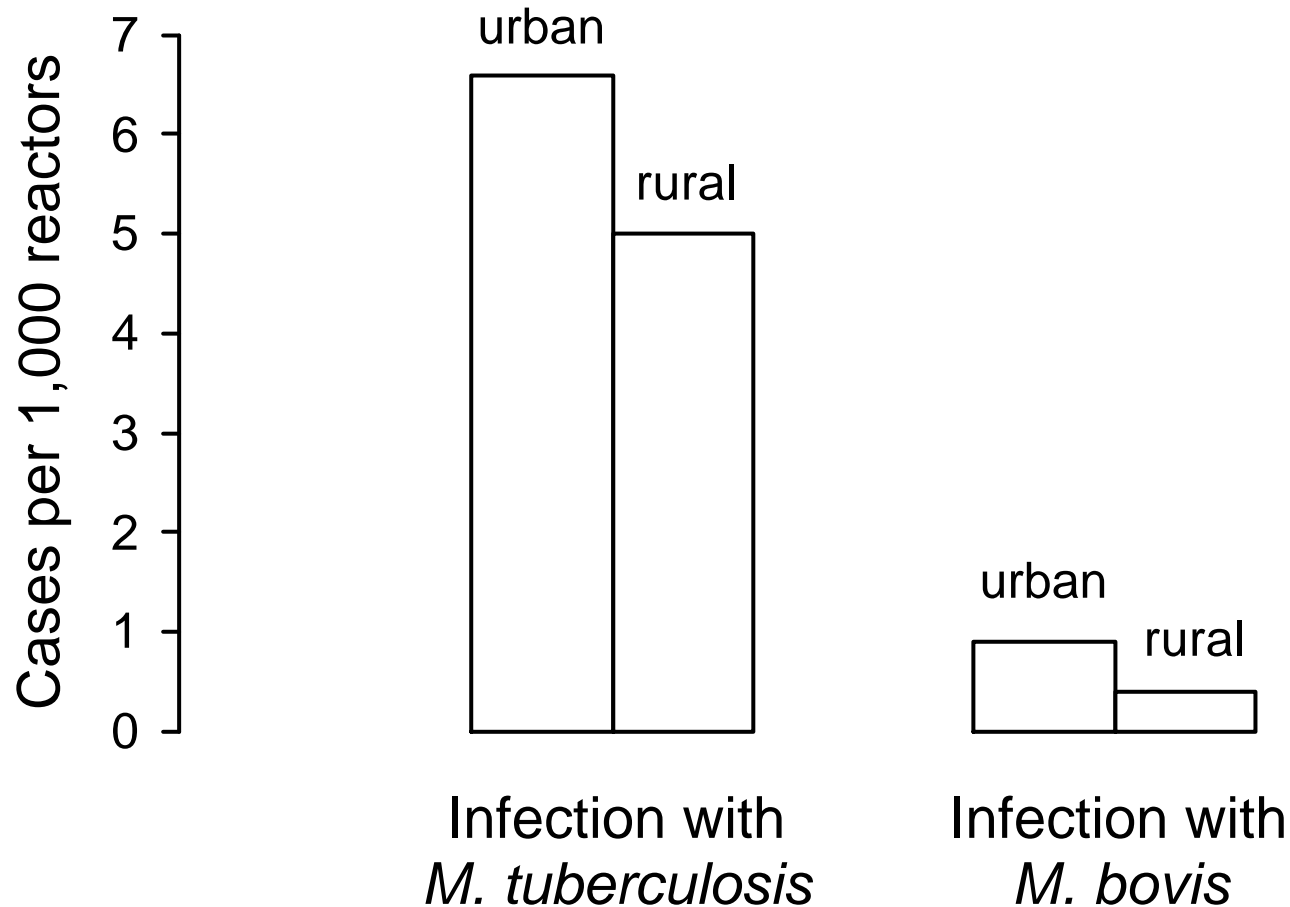

Magnus K. Bull World Health Organ 1966;35:483-508

Reported Tuberculosis Cases in the United States, 1953 - 1997

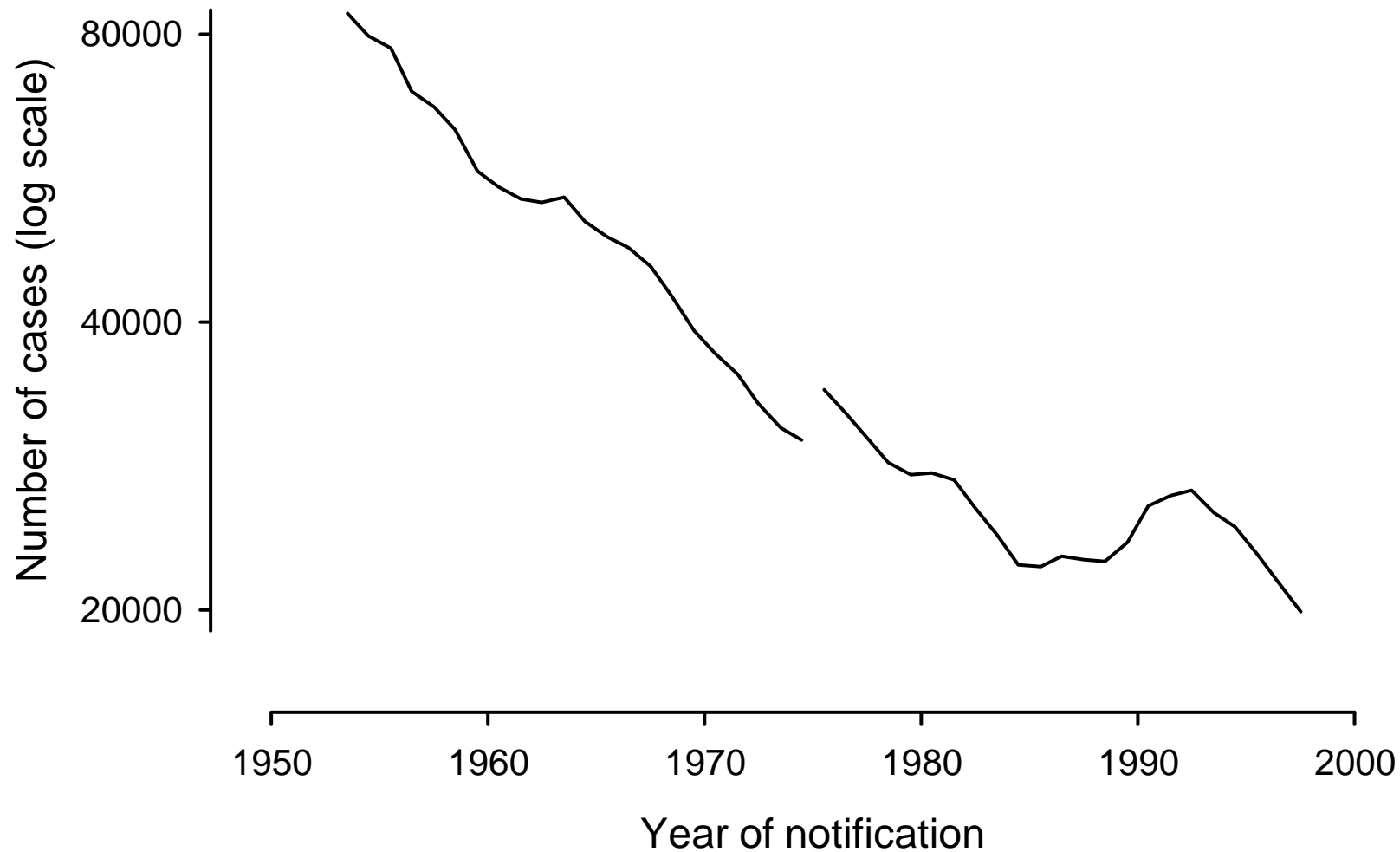

*Centers for Disease Control and Prevention. Reported Tuberculosis in the United States 1996:1997:5
Centers for Disease Control and Prevention. MMWR 1998;47:253-7*

Reported Tuberculosis Cases, Western Europe, 1974 - 1990

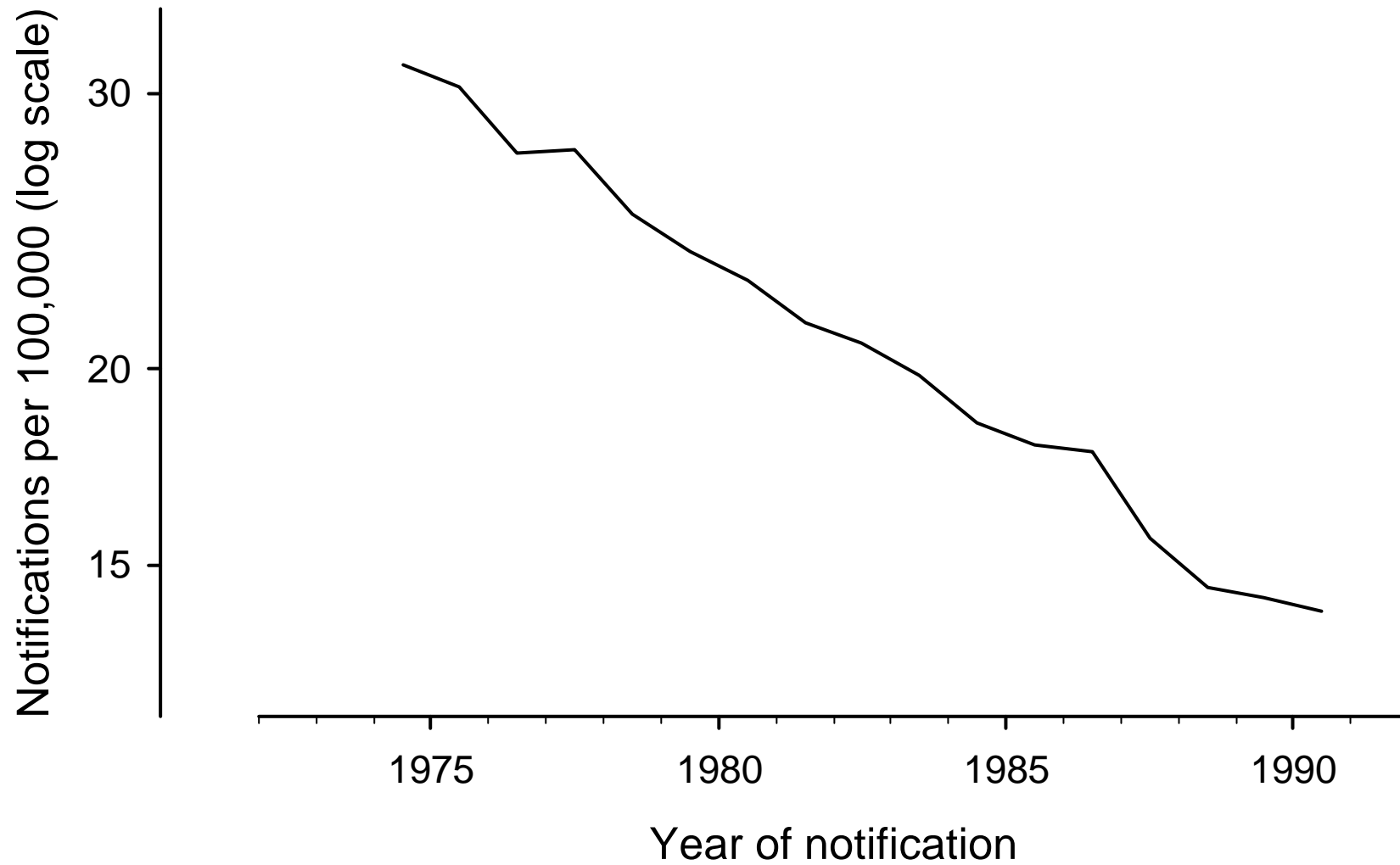

Raviglione MC, et al. Bull World Health Organ 1993;71:297-306

Reported Tuberculosis Cases, Western Europe, 1974 - 1990

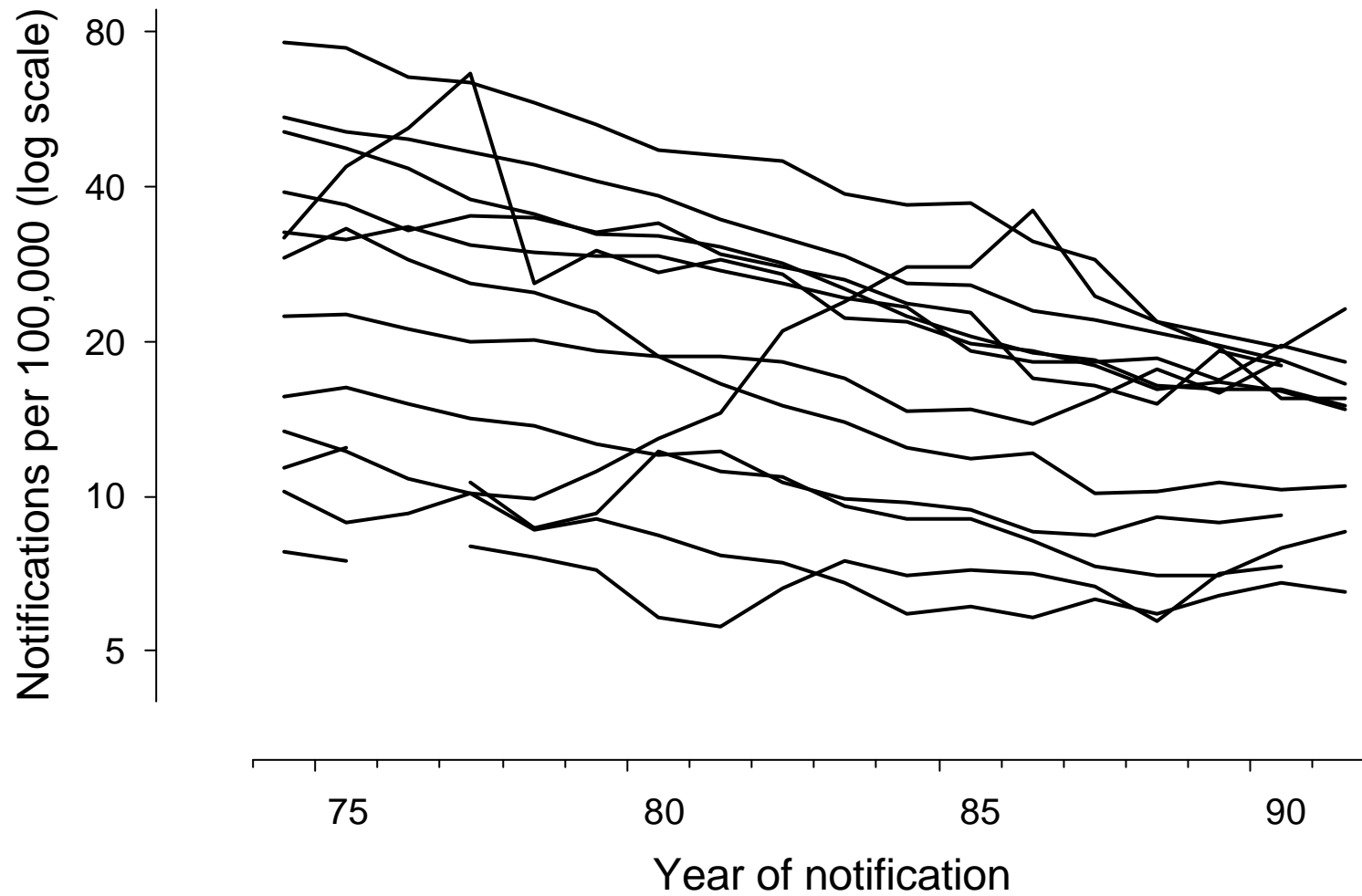

Raviglione MC, et al. Bull World Health Organ 1993;71:297-306

Tuberculosis Notification Rates Among Males, Cross-Sectional Observations, Finland 1954 -1984

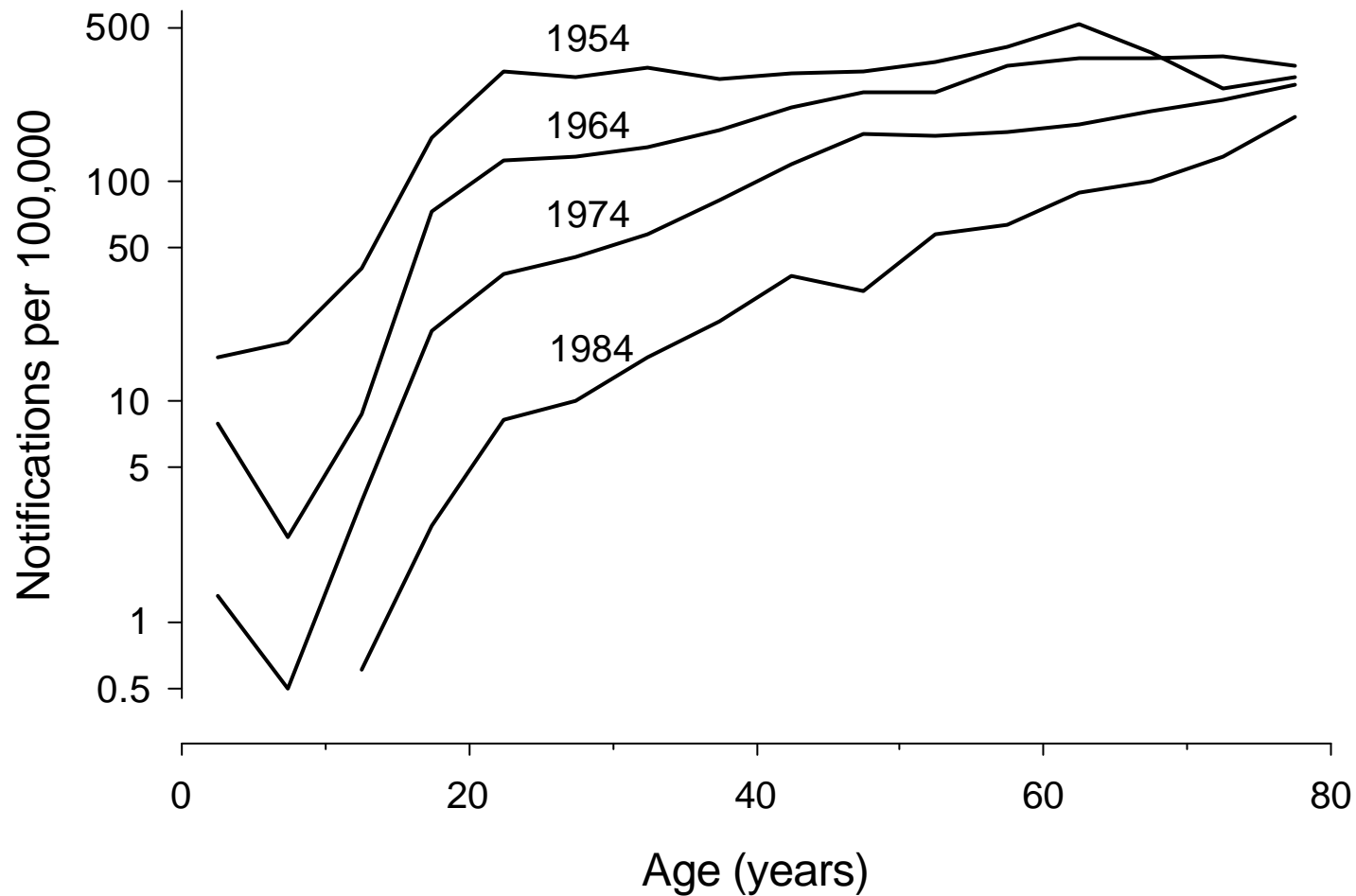

Tuberculosis Notification Rates Among Males, by Birth Cohort, Finland 1954 -1984

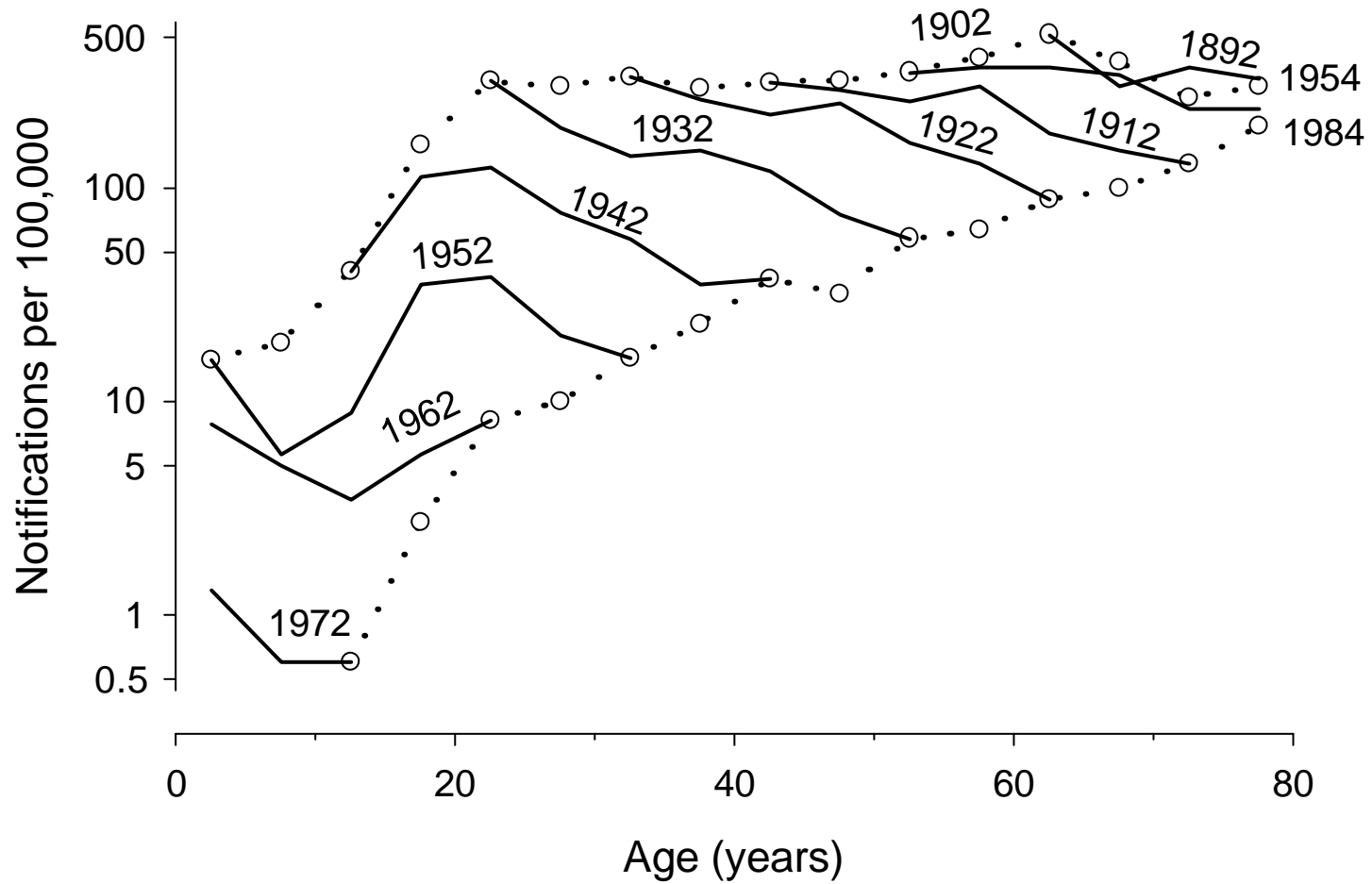

Average Annual Incidence of Tuberculosis Among Women, Cross-Sectionally and by Birth Cohort, Upstate New York

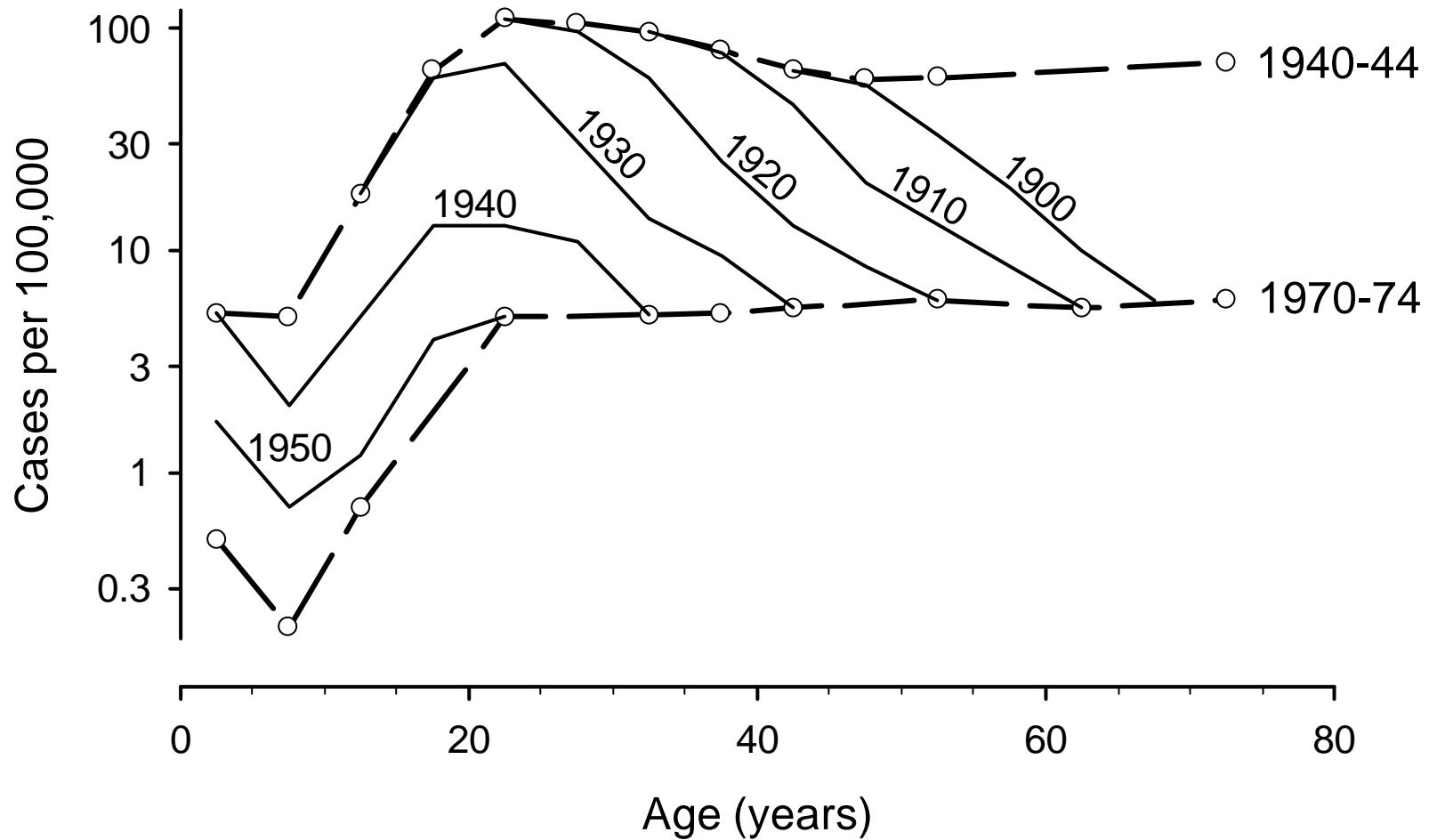

Hinman AR, et al. *Am J Epidemiol* 1976;103:486-97

Foreign Born-to-Canada Born Risk Ratios for Tuberculosis in Canada, 1970 - 1972

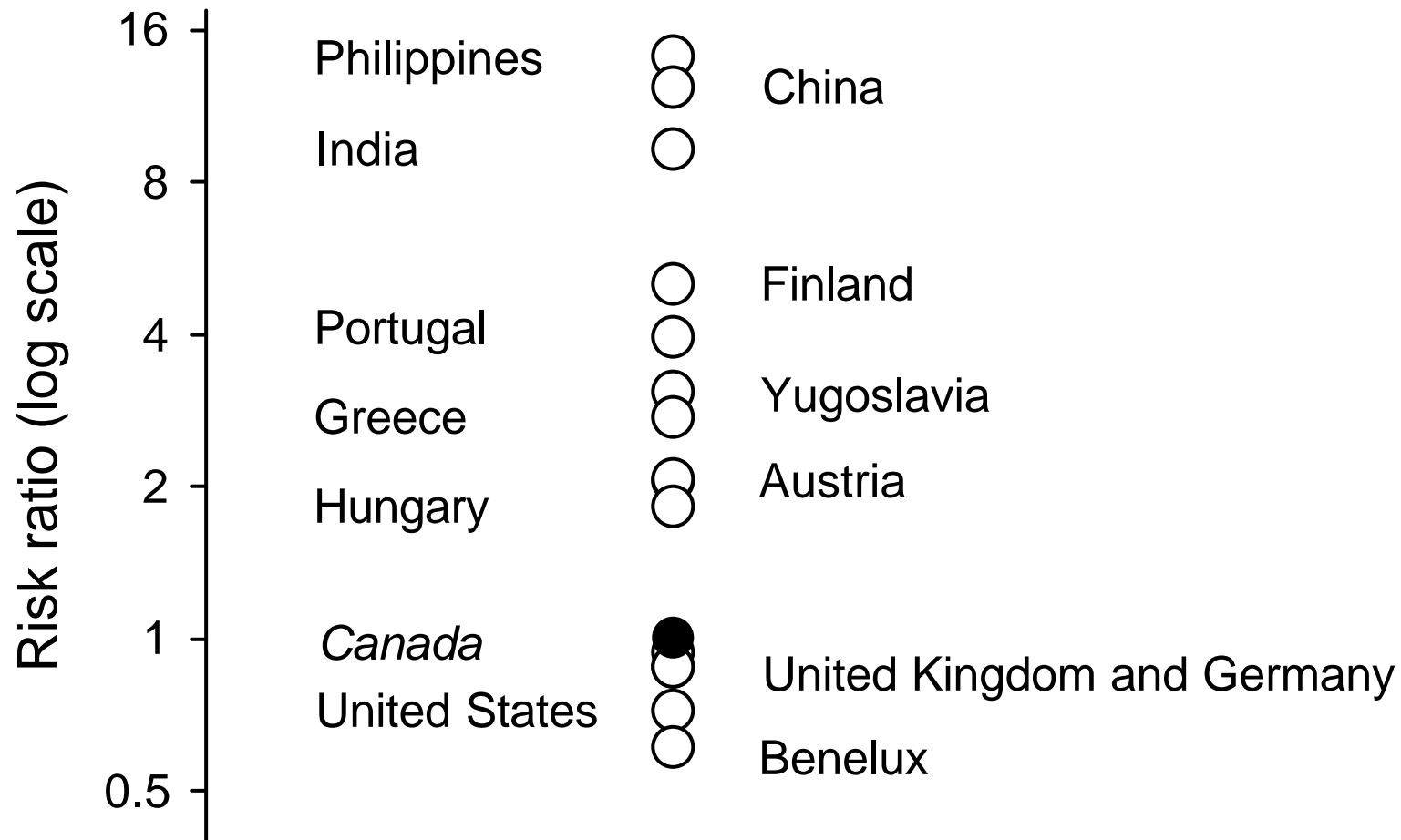

Enarson D, et al. Am Rev Respri Dis 1979;119:11-8

Age-Adjusted Rate Ratios for Tuberculosis among Foreign-Born Persons, United States, 1986 - 1993

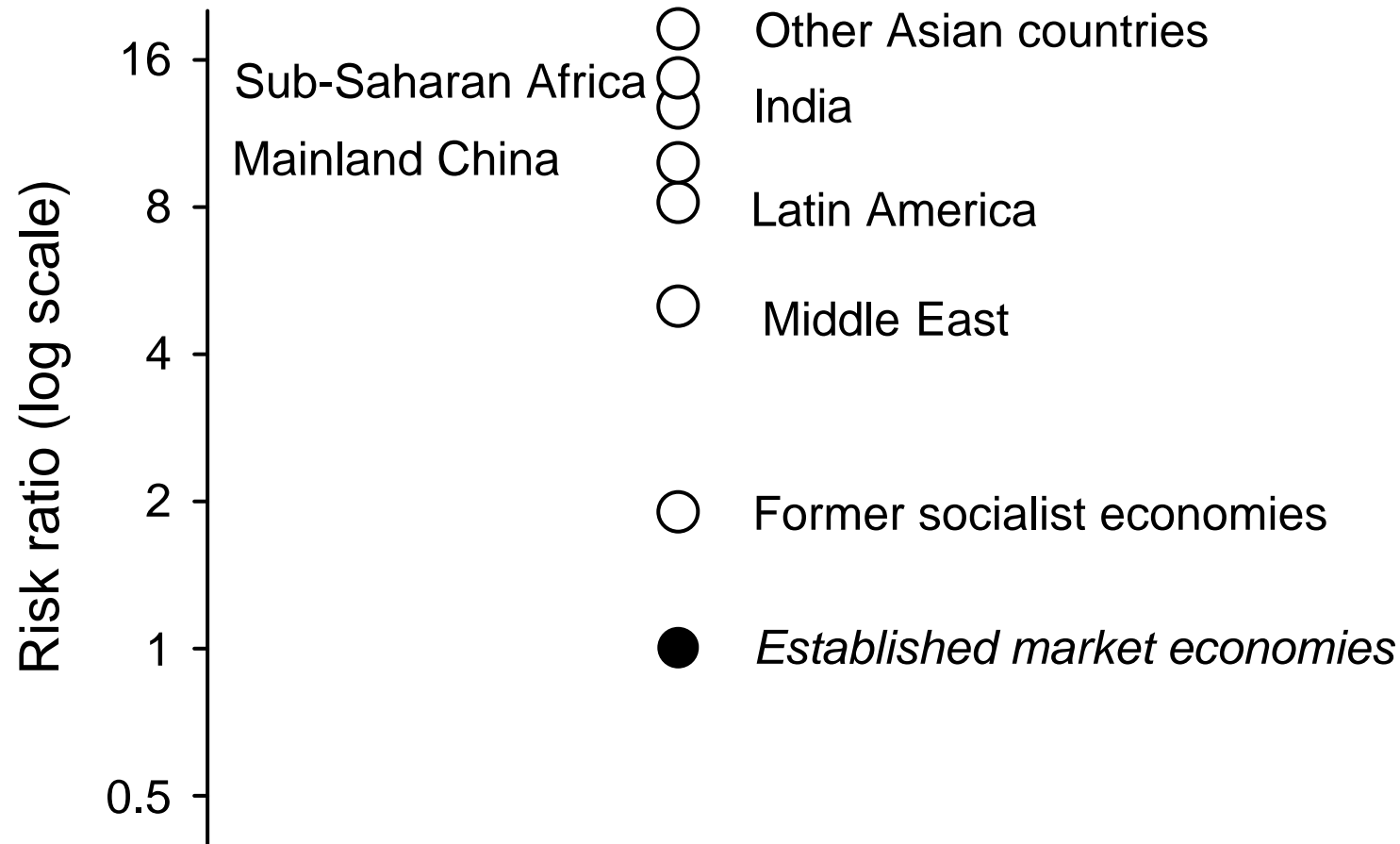

McKenna MT, et al. N Engl J Med 1995;332;1071-6

Estimated Incidence of Tuberculosis in the World in 1995

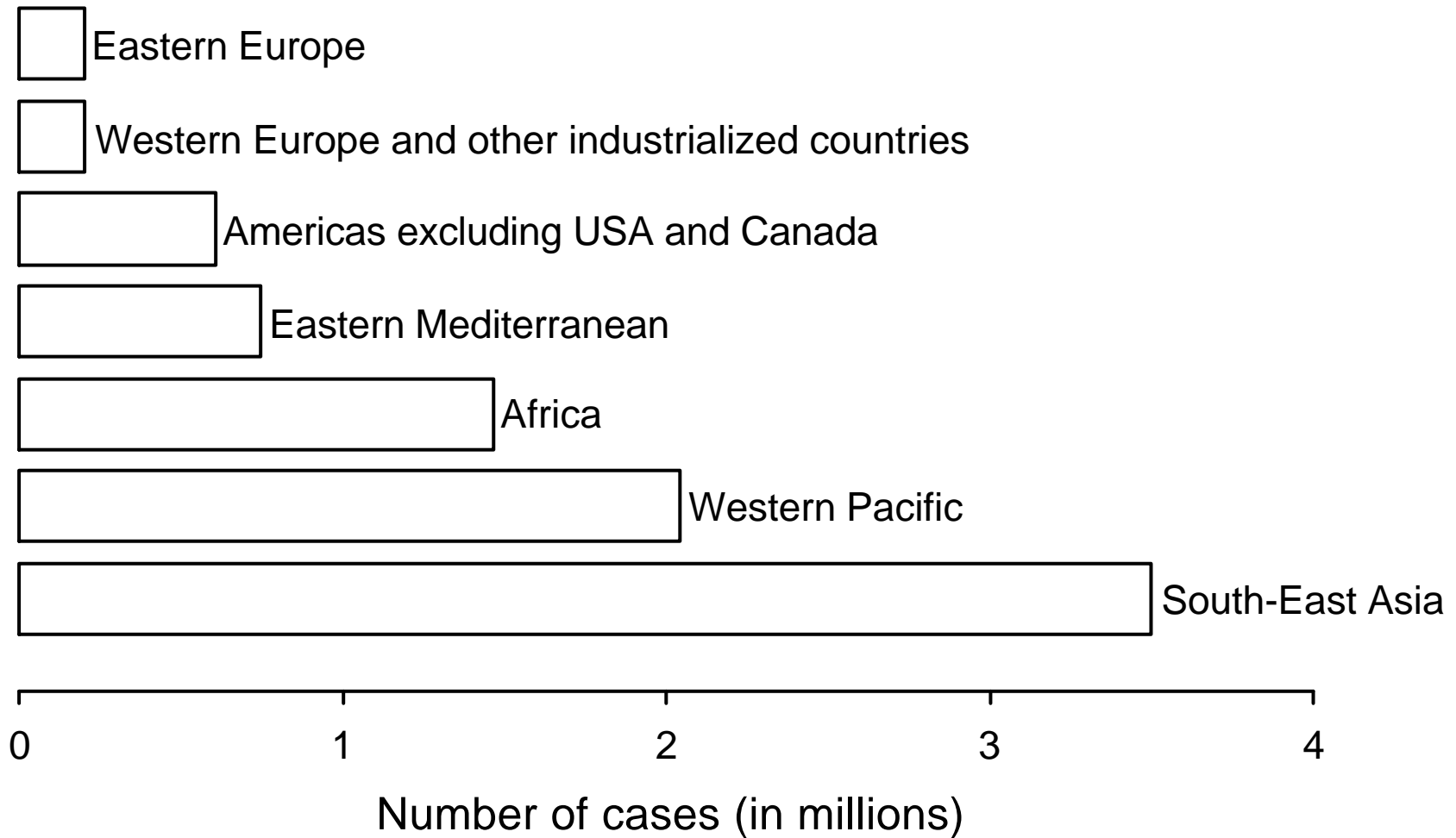

Age-Specific Notification Rates of Infectious Tuberculosis among Females, Norway, 1946 and 1972

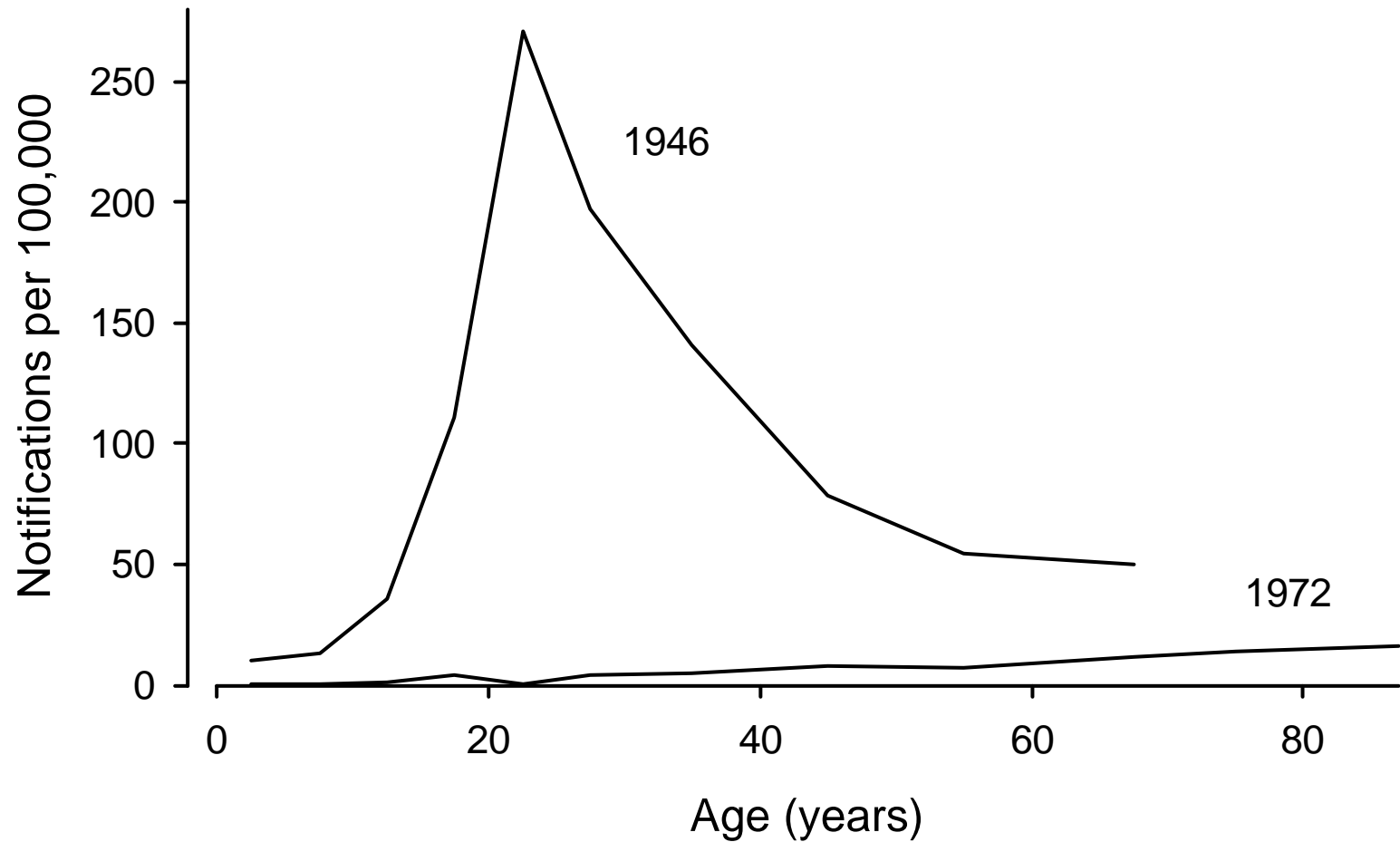

Bjartveit K. Scand J Respir Dis 1978;(suppl):28-35

Age-Specific Notification Rates of Smear-Positive Tuberculosis, by Sex, Senegal, 1997

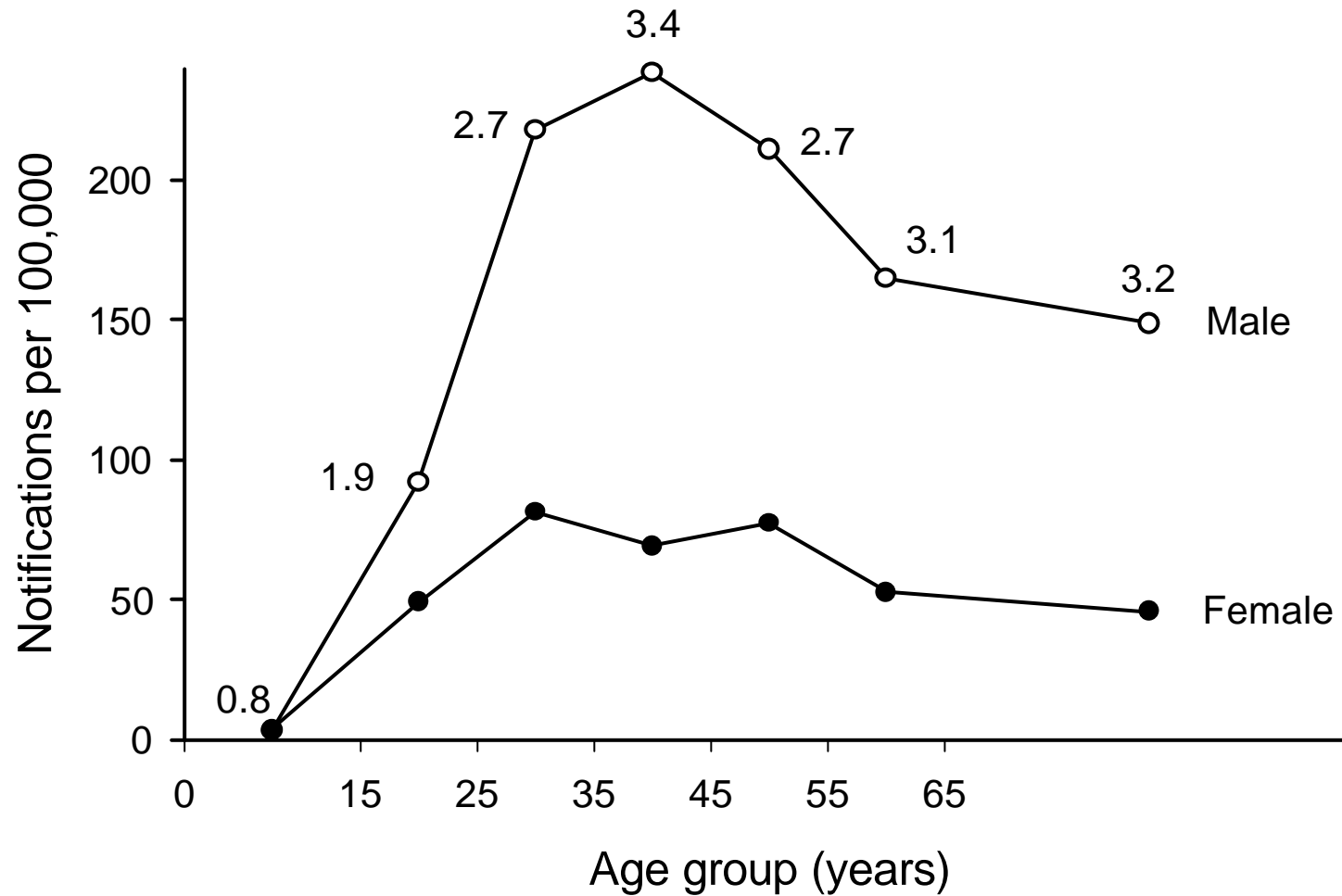

Incidence of Pulmonary Tuberculosis, by Sex, Denmark 1921 - 1957

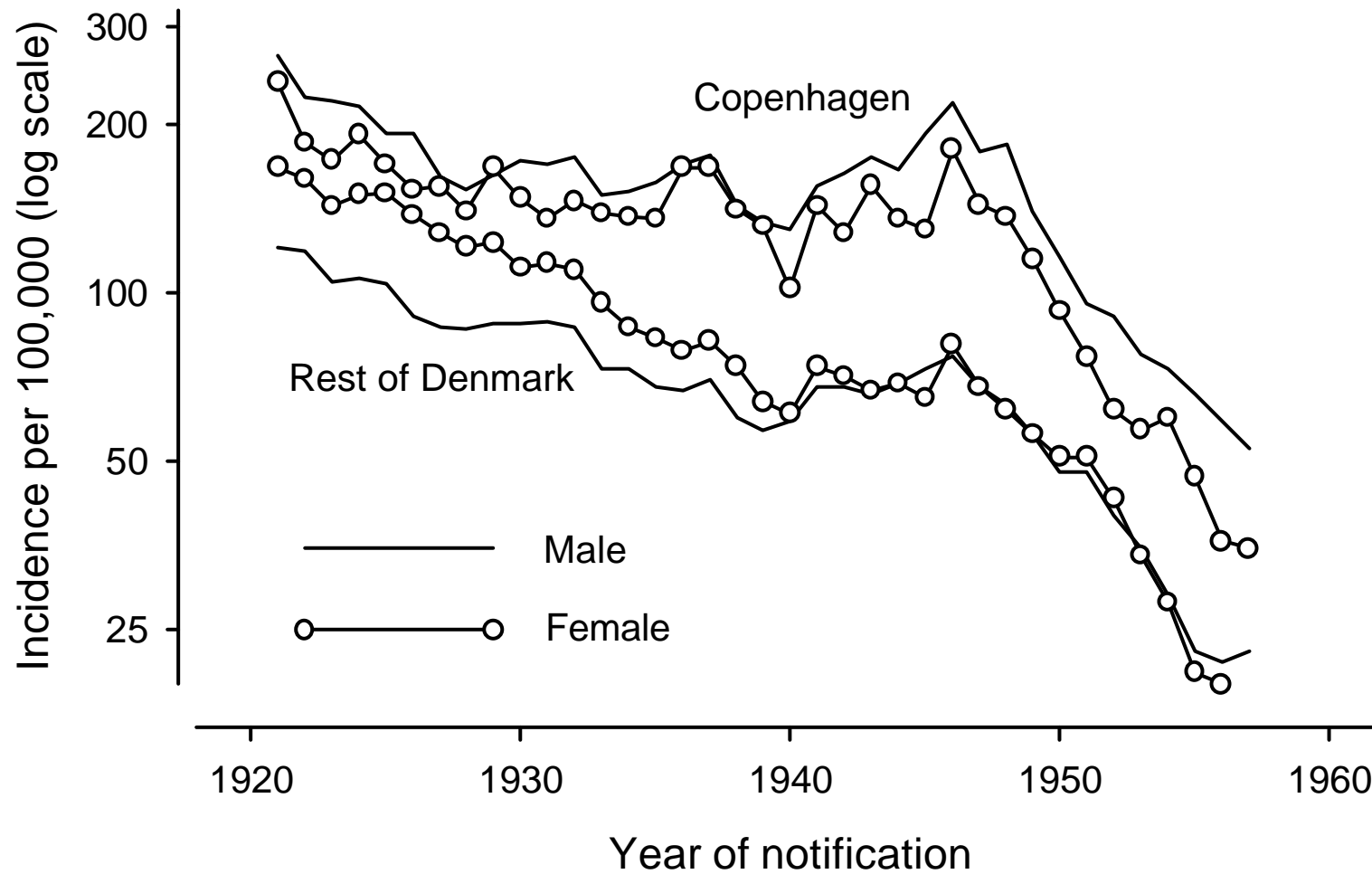

Male-to-Female Rate Ratio in the Incidence of Pulmonary Tuberculosis, Denmark, 1921 - 1957

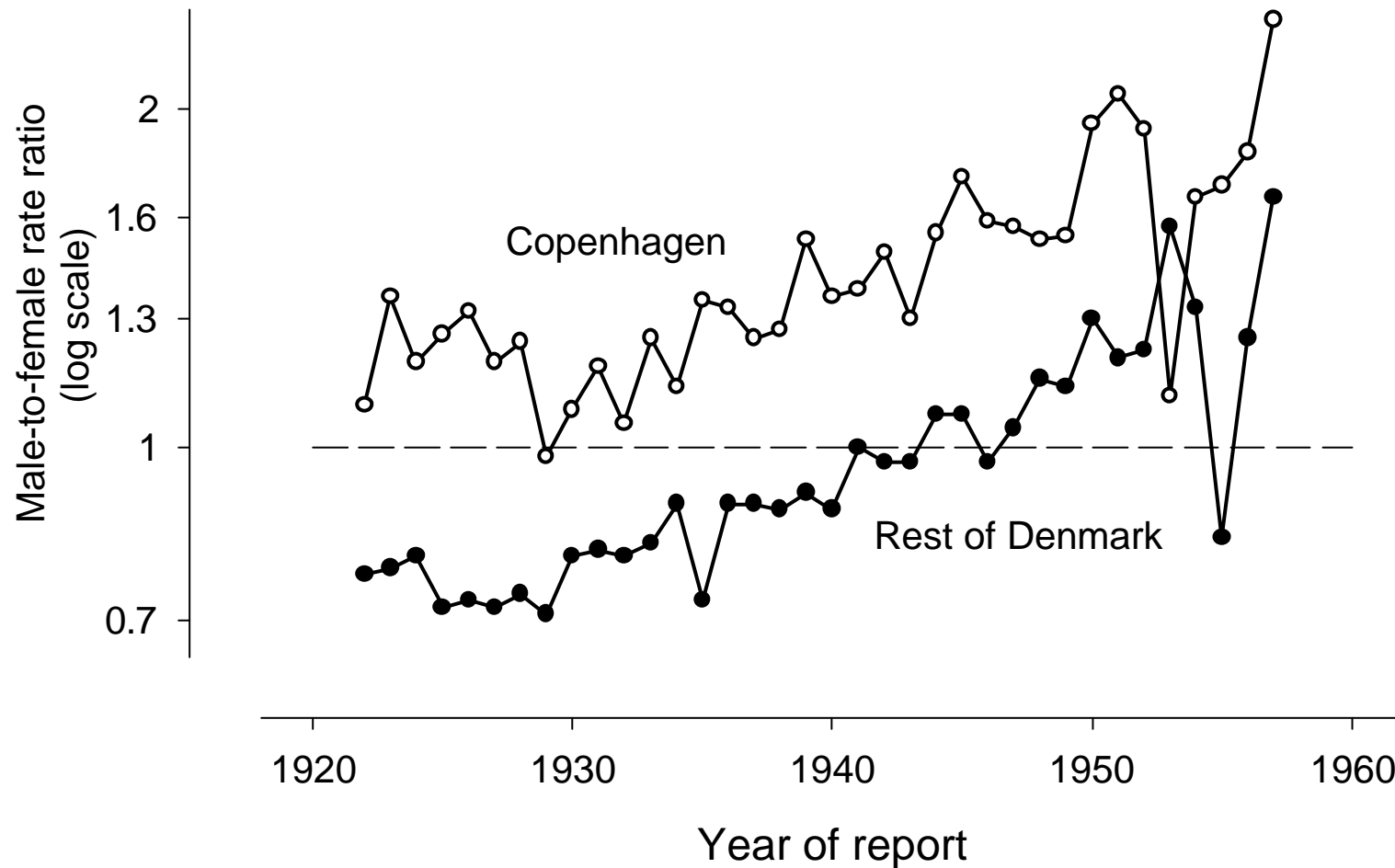

Groth-Petersen E, et al. Bull World Health Organ 1959;21:5-49

Incidence Rates of New Cases of Tuberculosis by Socioeconomic Level, Upstate New York, 1973

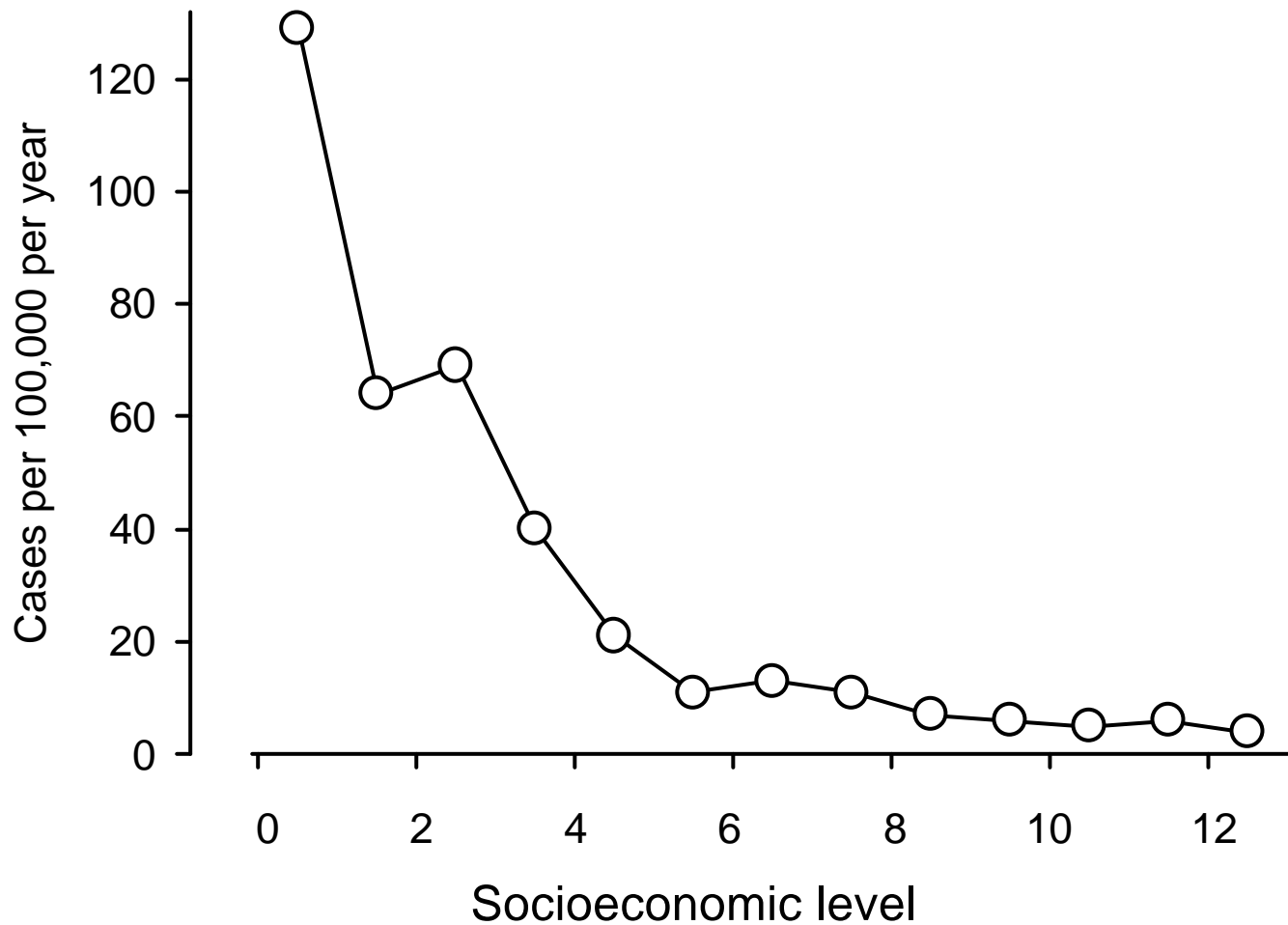

Hinman AR, et al. Am J Epidemiol 1976;103:486-97

White-to-Nonwhite Tuberculosis Case Rate Ratios, United States, 1953 - 1987

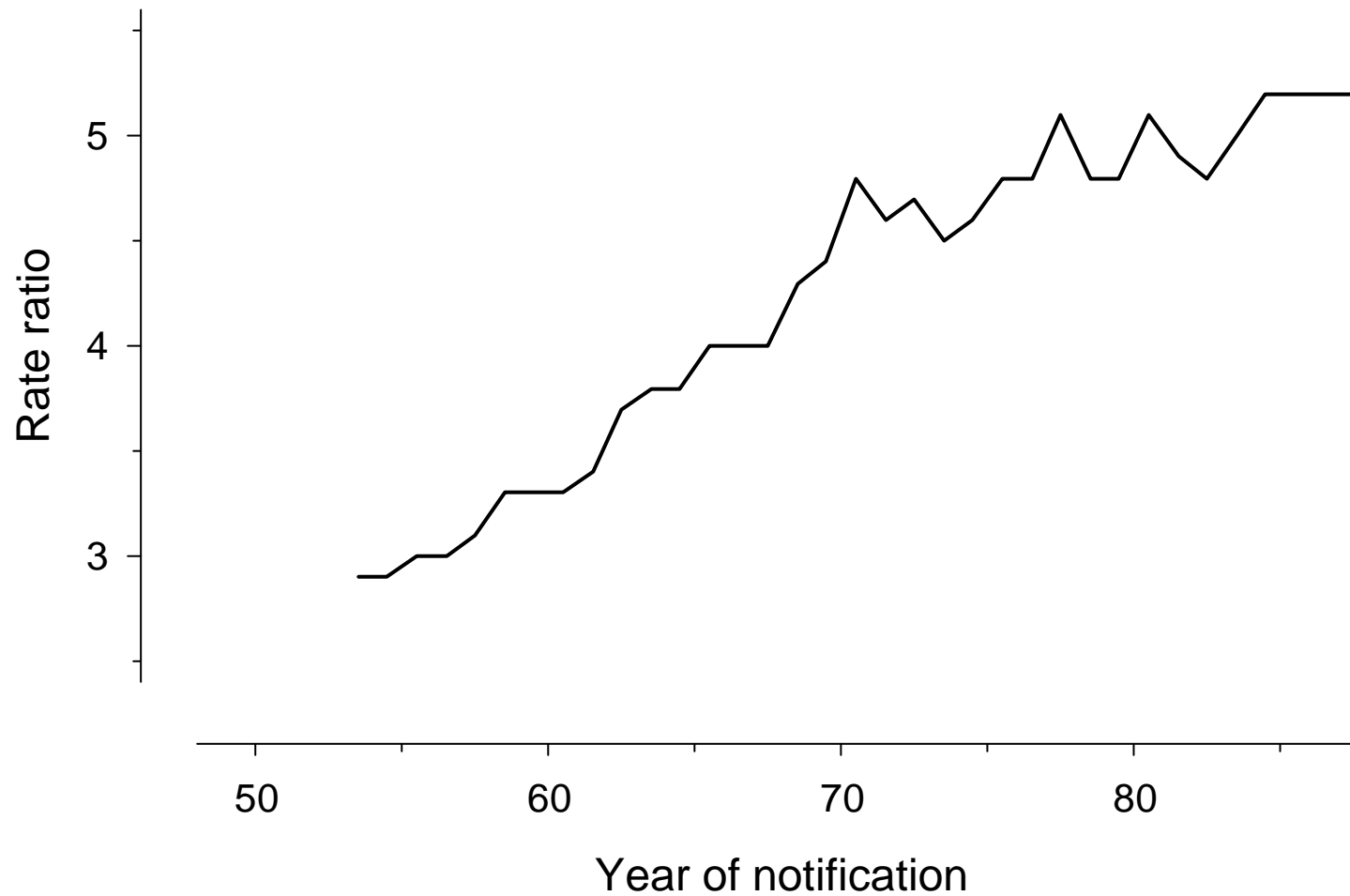

Rieder HL, et al. J Am Med Assoc 1989;262:385-9

Average Annual Decline in Tuberculosis Incidence, by Age, Race, and Sex, United States, 1963 - 1984

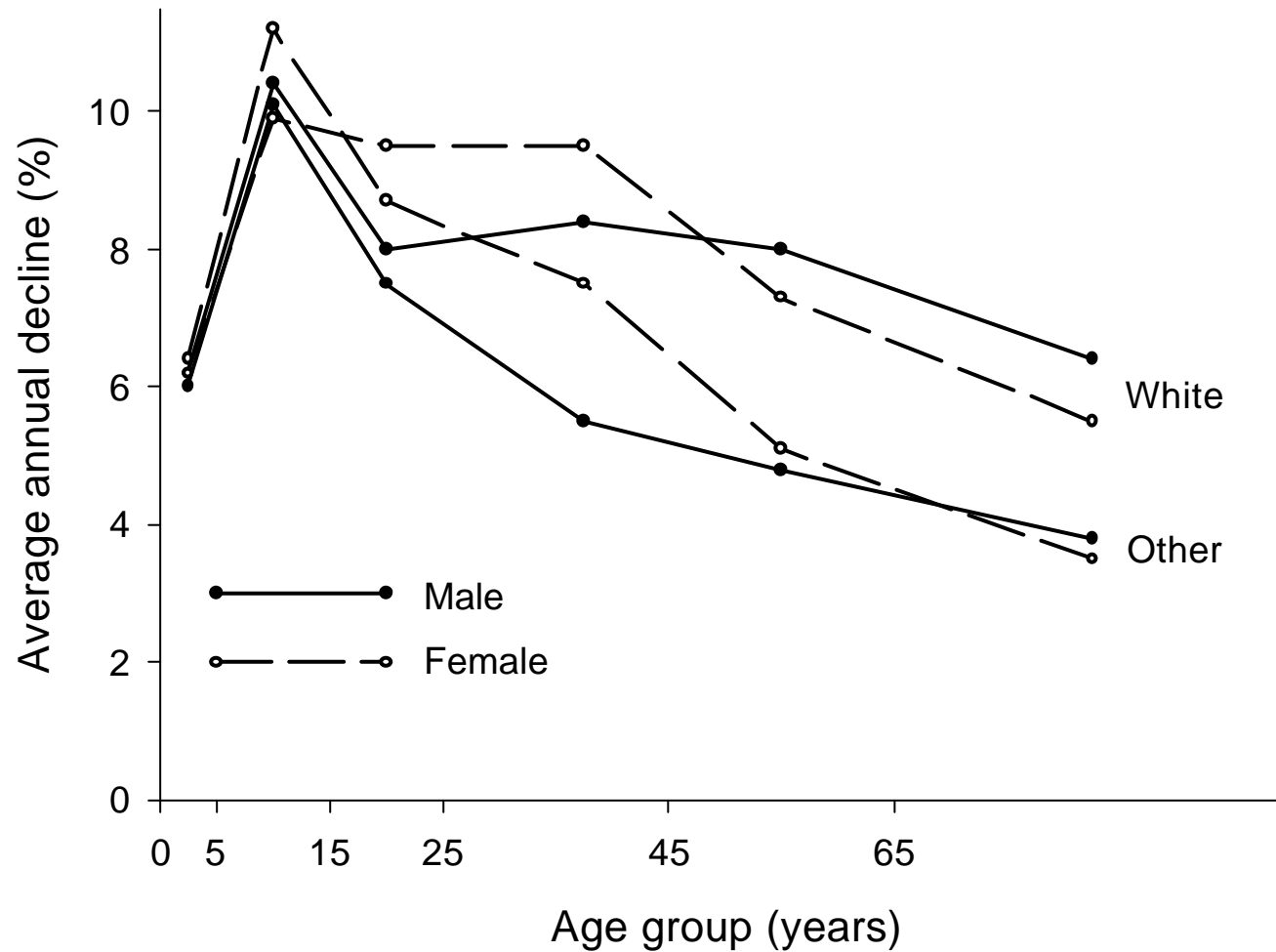

Tuberculosis Cases Rates Among Children Aged less than Five Years, by Race, United States, 1981 - 1992

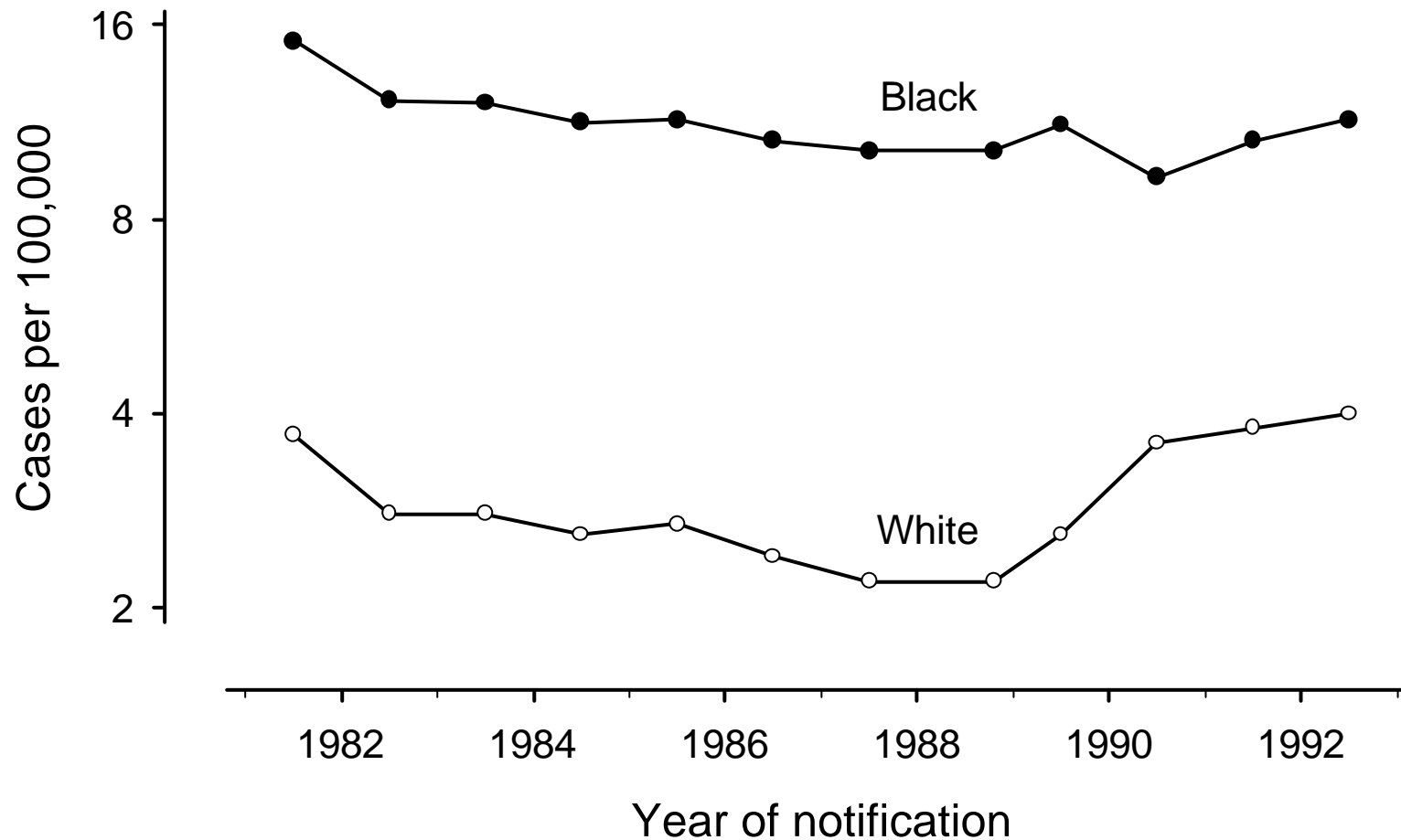

*Centers for Disease Control and Prevention
Tuberculosis Statistics in the United States, 1991 and 1992*

Reported Tuberculosis Cases in Sweden, by Country of Origin, 1984 - 1996

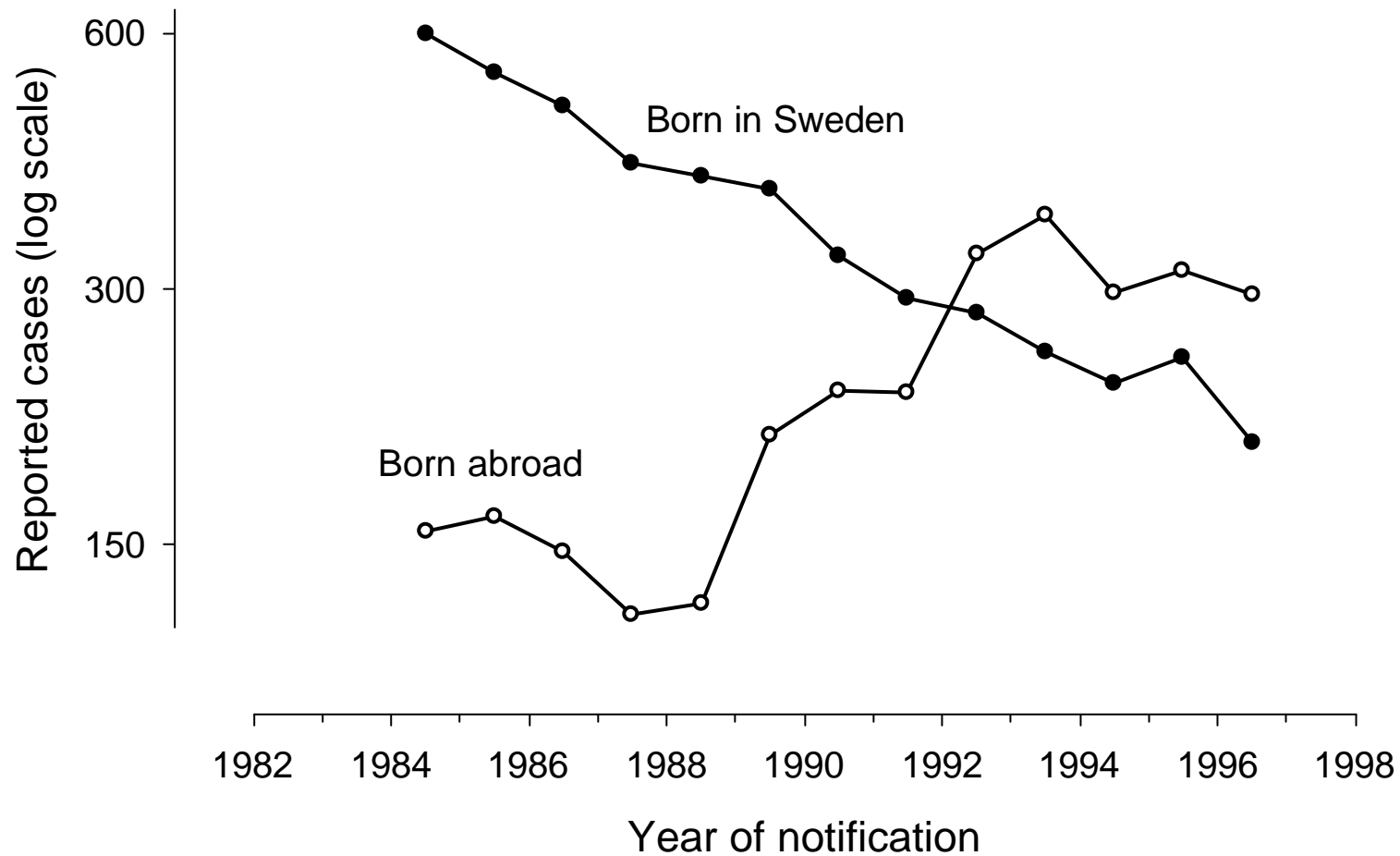

*Data courtesy: Romanus V. Swedish Institute for Infectious Disease Control, 1997
EuroTB. Surveillance of Tuberculosis in Europe, 1998*

Proportion of Tuberculosis Cases Who Were Foreign-Born, WHO Europe Region, 1996

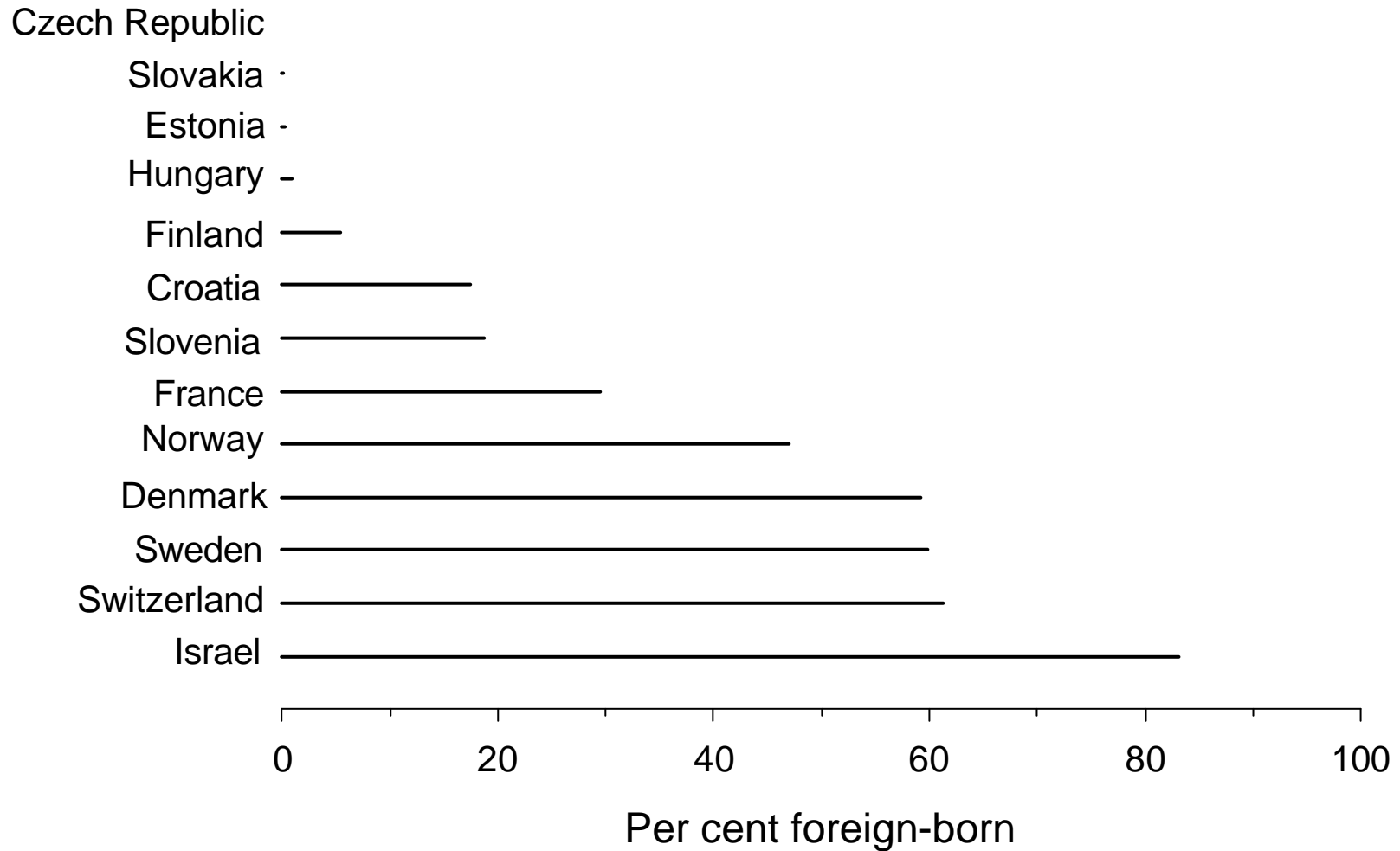

Reported Cases of Tuberculosis by Citizenship, Switzerland, 1990

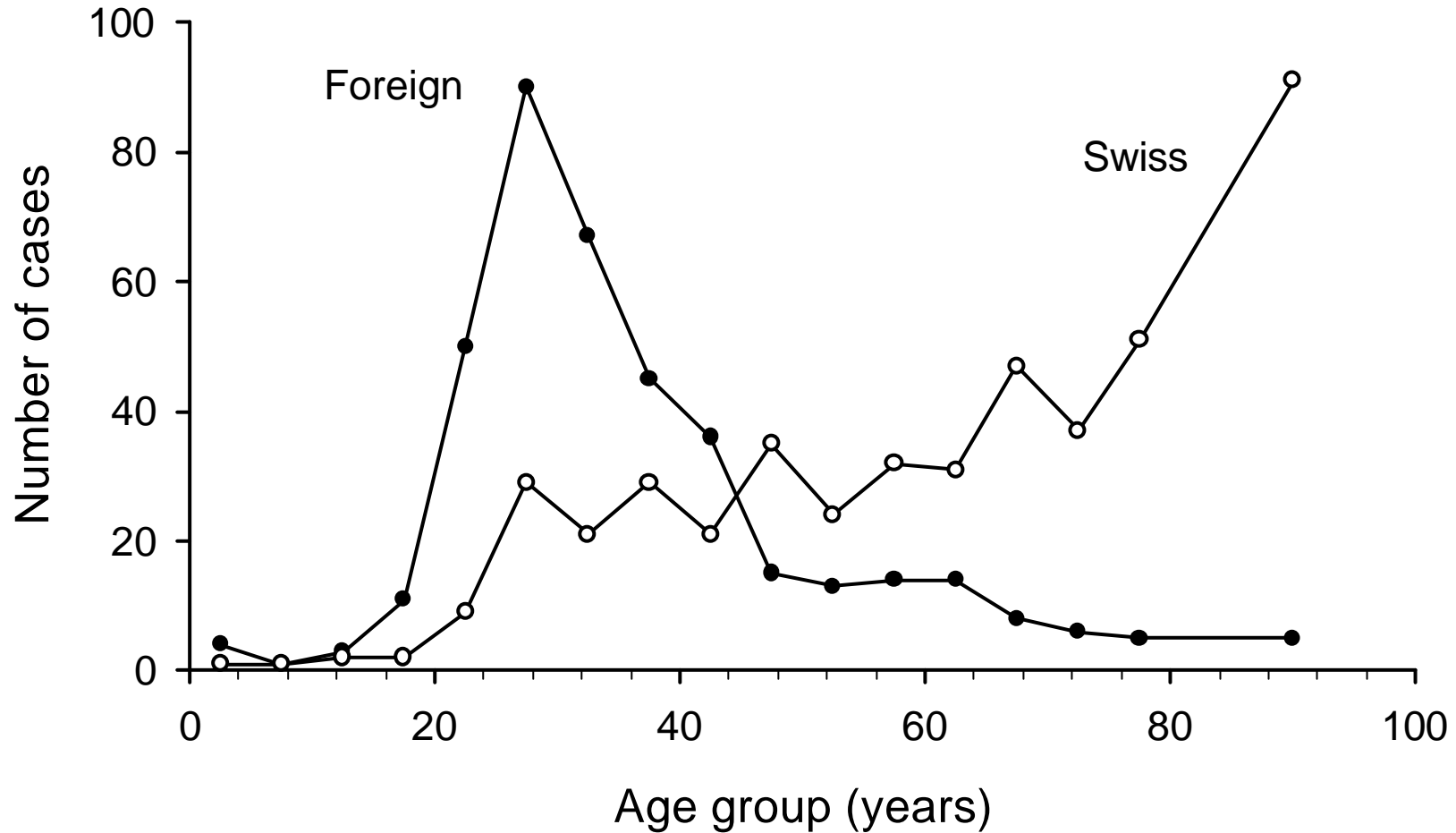

Interval Between Entry or Re-Entry to Britain and Notification of Tuberculosis Among Asians in London

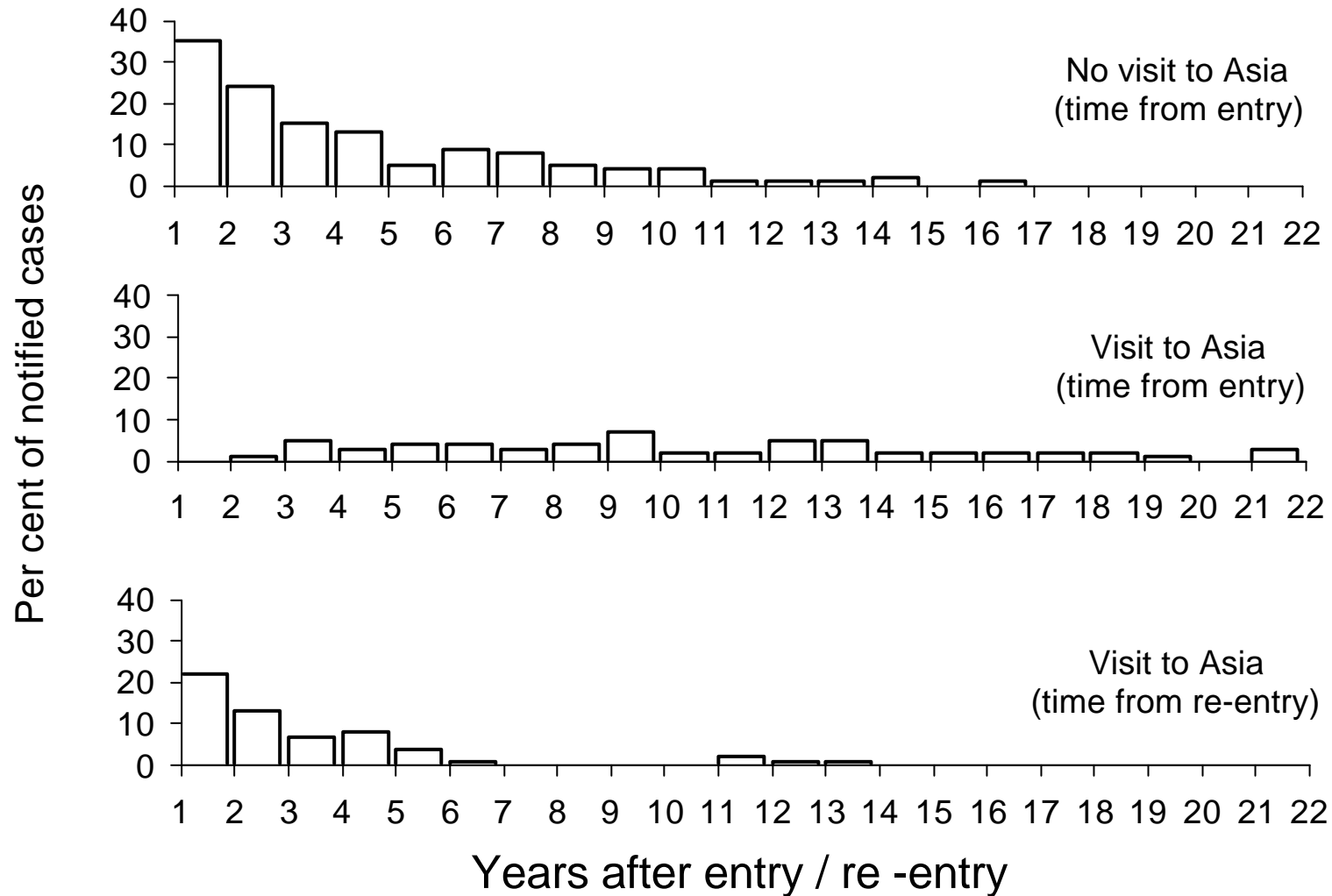

Incidence of pulmonary tuberculosis Among Males by Residence, Denmark, 1950 - 1952

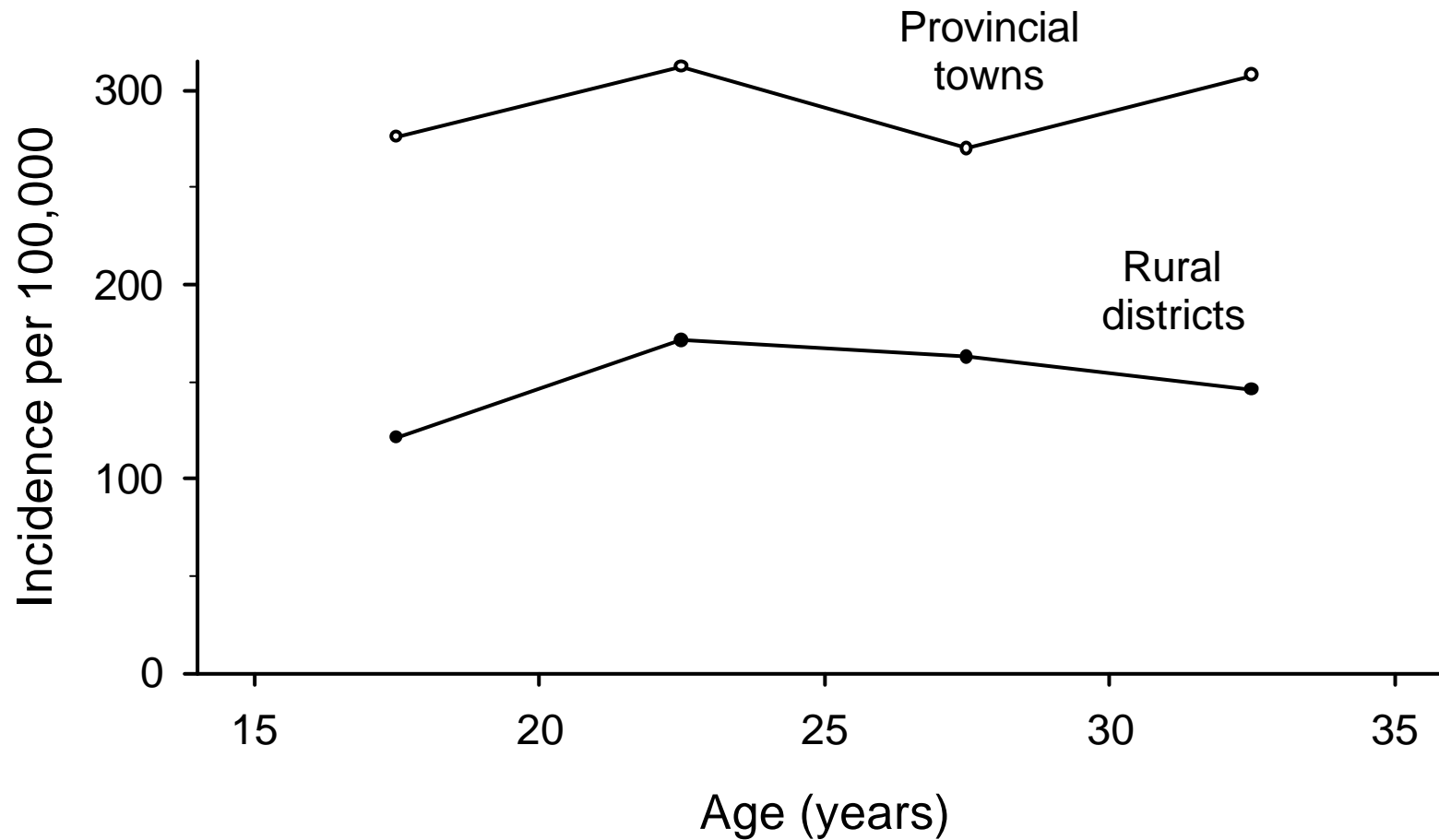

Horwitz O, et al. Bull World Health Organ 1961;24:793-805

Incidence of Pulmonary Tuberculosis Among Married Men, by Residence, Denmark, 1960 - 1968

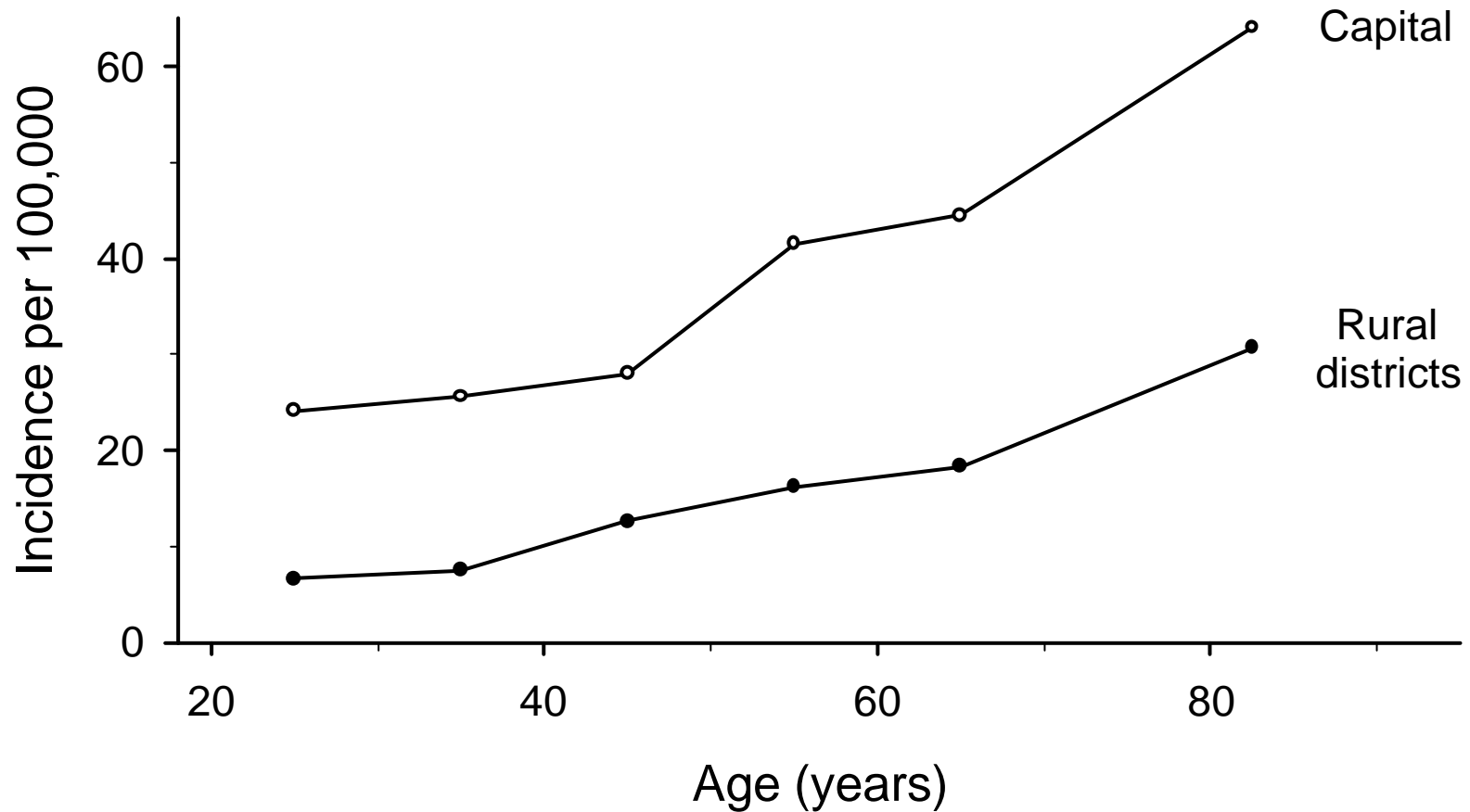

Christensen O. Scand J Respir Dis 1978(suppl):21-7

Incidence of pulmonary tuberculosis Among Males by Marital Status in Copenhagen, Denmark, 1960 - 1968

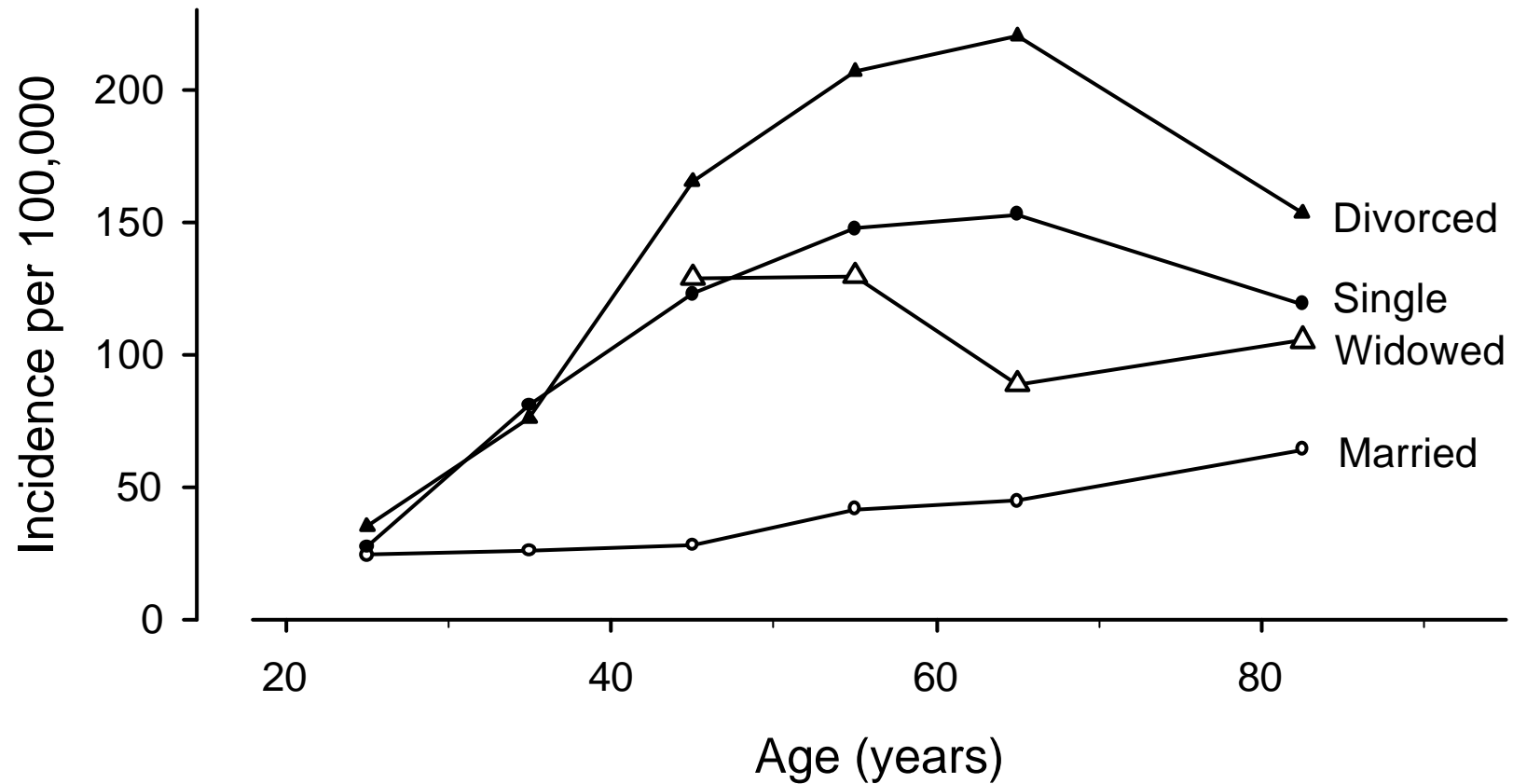

Christensen O. Scand J Respir Dis 1978(suppl):21-7

Nosocomial Tuberculosis Outbreak in a Hospital in Verona, Italy

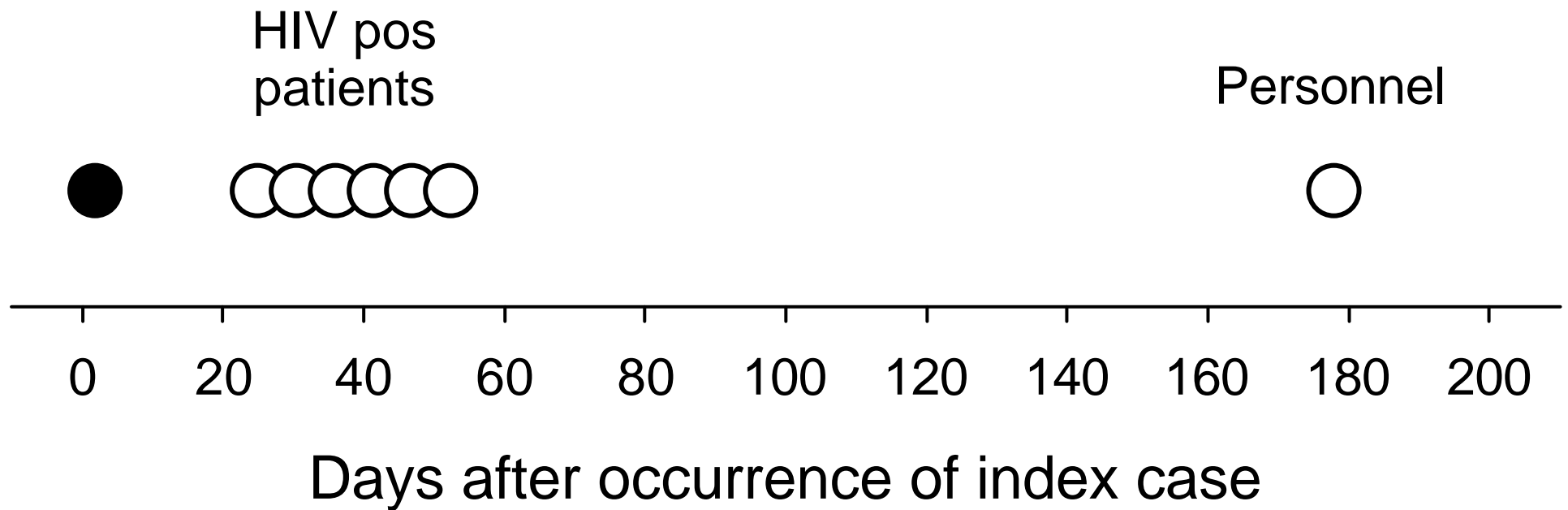

di Perri G, et al. Lancet 1989;2:1502-4

Tuberculosis among AIDS Patients, by Race / Ethnicity, Florida, United States, 1981 - 1986

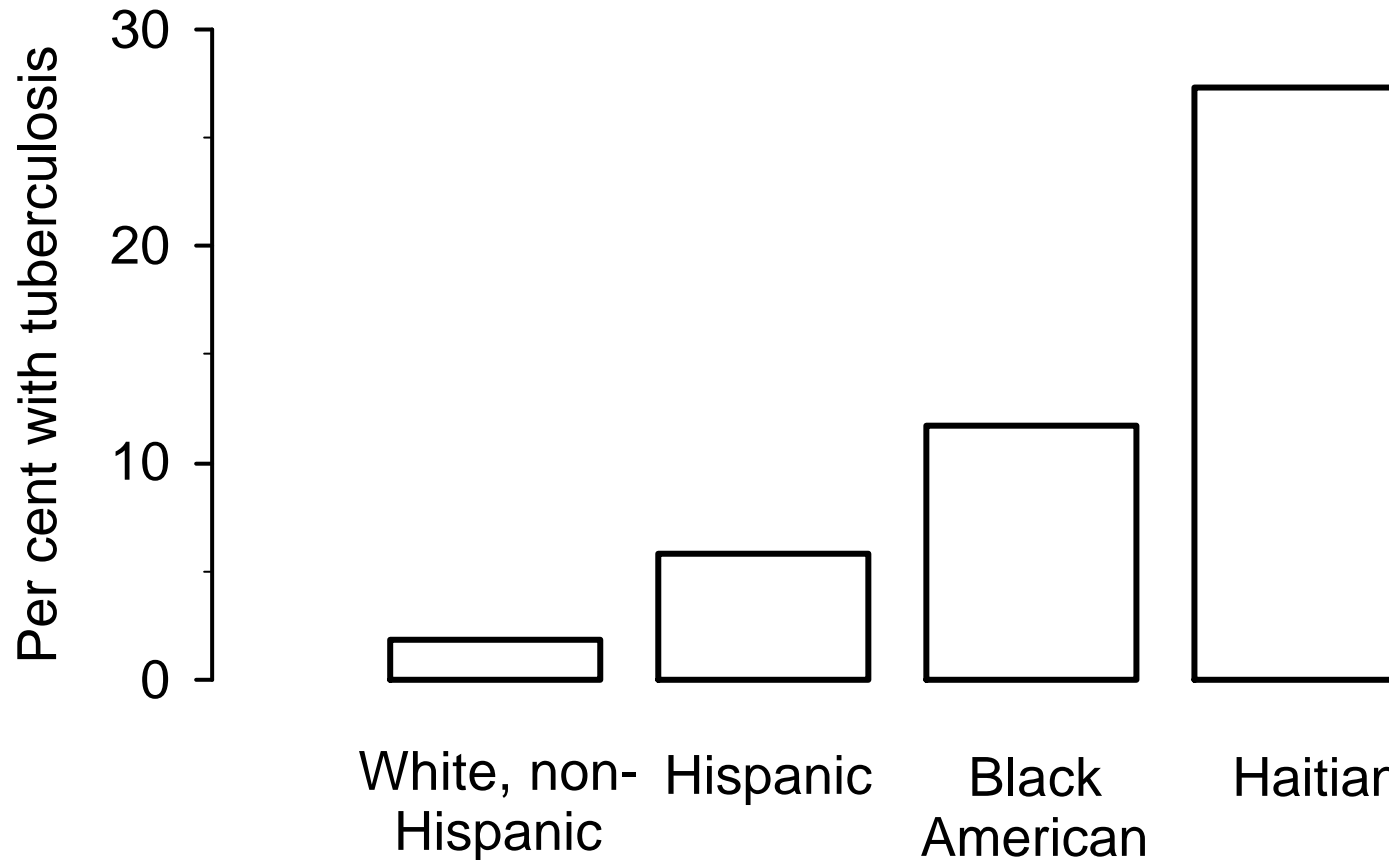

Rieder HL, et al. Arch Intern Med 1989;149:1268-73

Determinants for the Frequency of HIV-Associated Tuberculosis in a Community

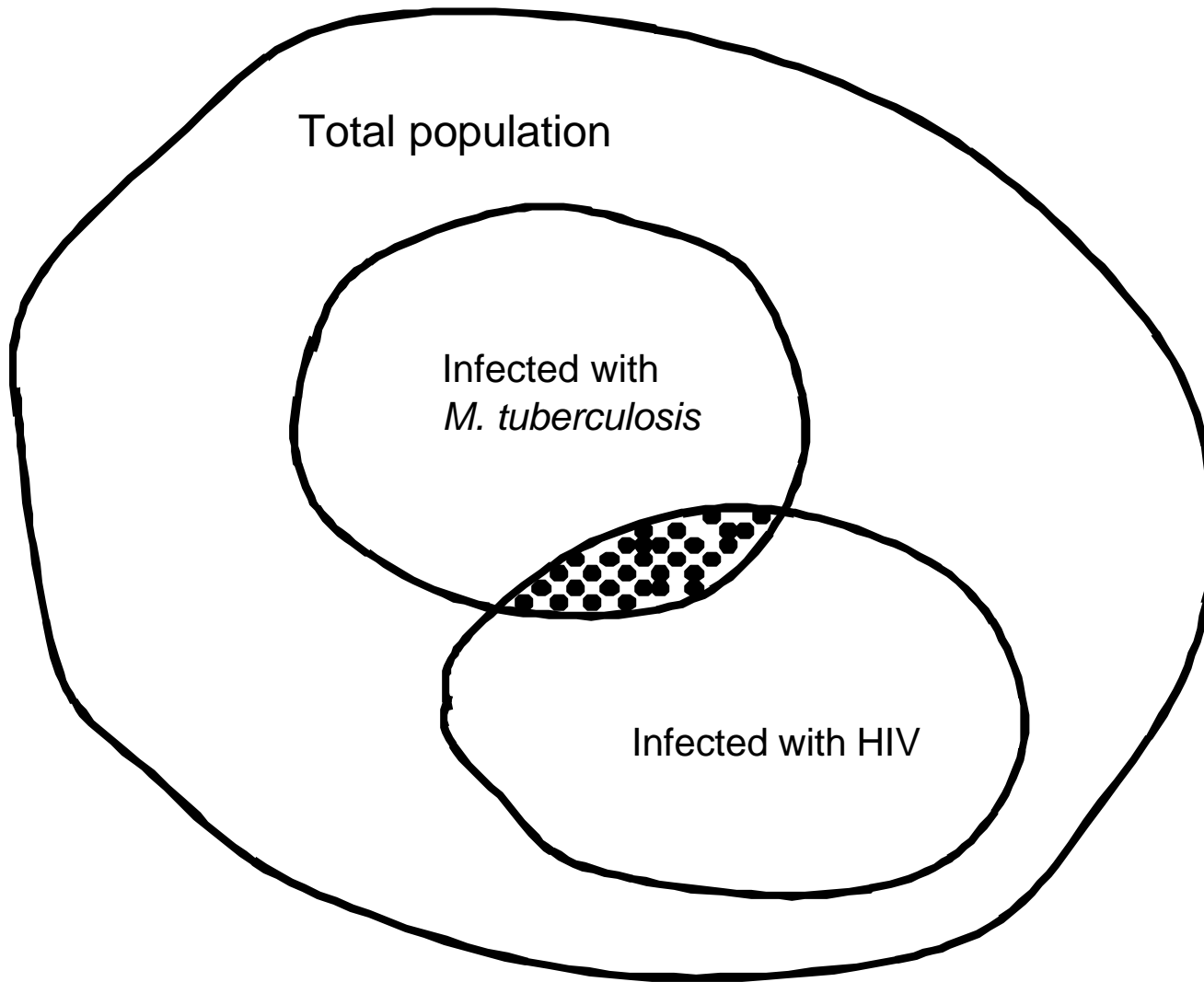

Prevalence of infection with
M. tuberculosis

Prevalence and incidence
of HIV infection

Overlap of the two respective
population segments

Factors Associated with Extrapulmonary Tuberculosis at AIDS Diagnosis, Selected European Countries

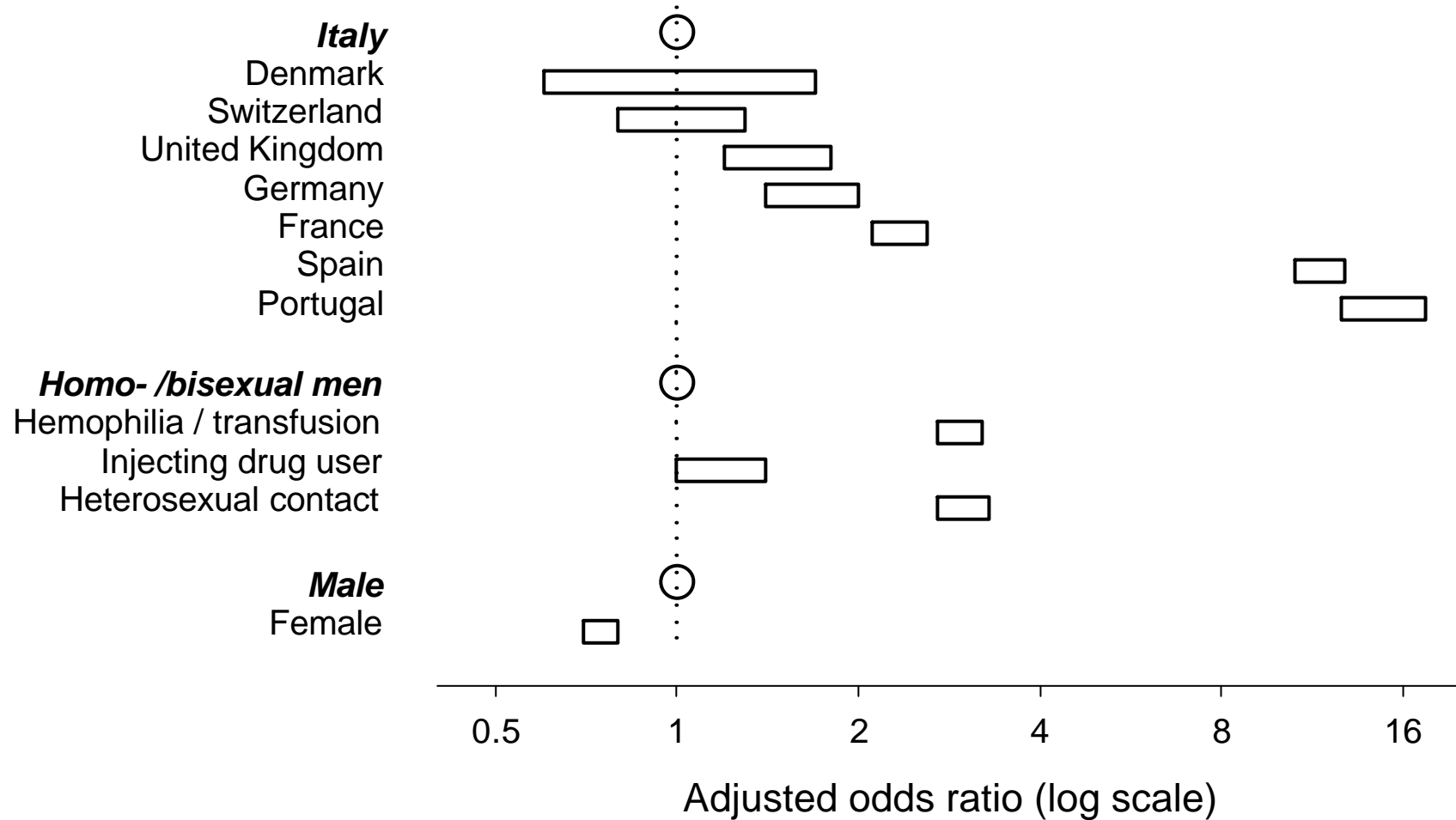

Notifications of Tuberculosis, by Type of Disease, Tanzania Mainland, 1984 - 1995

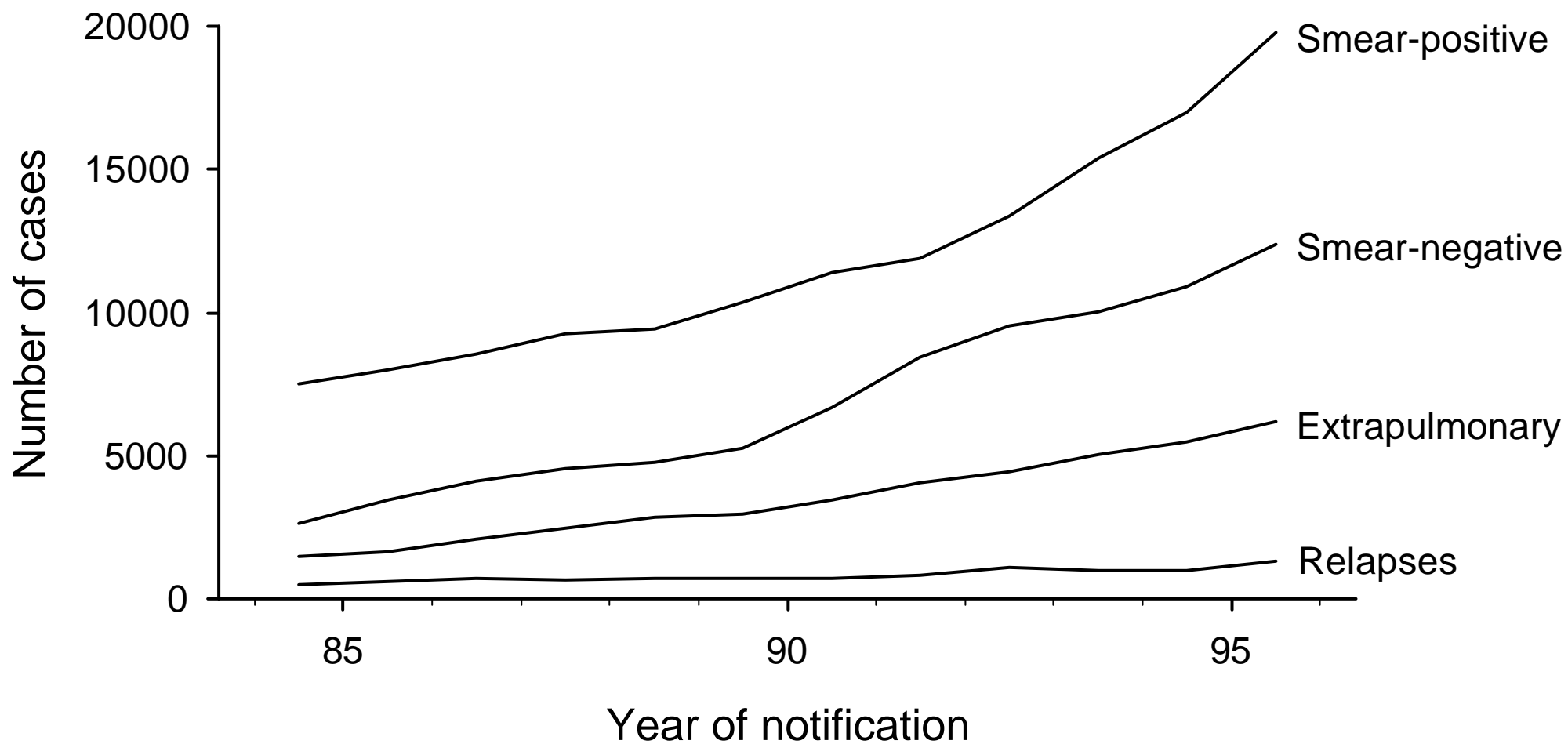

Notification Rates of Sputum Smear-Positive Tuberculosis, by Age, Tanzania Mainland, 1984 and 1995

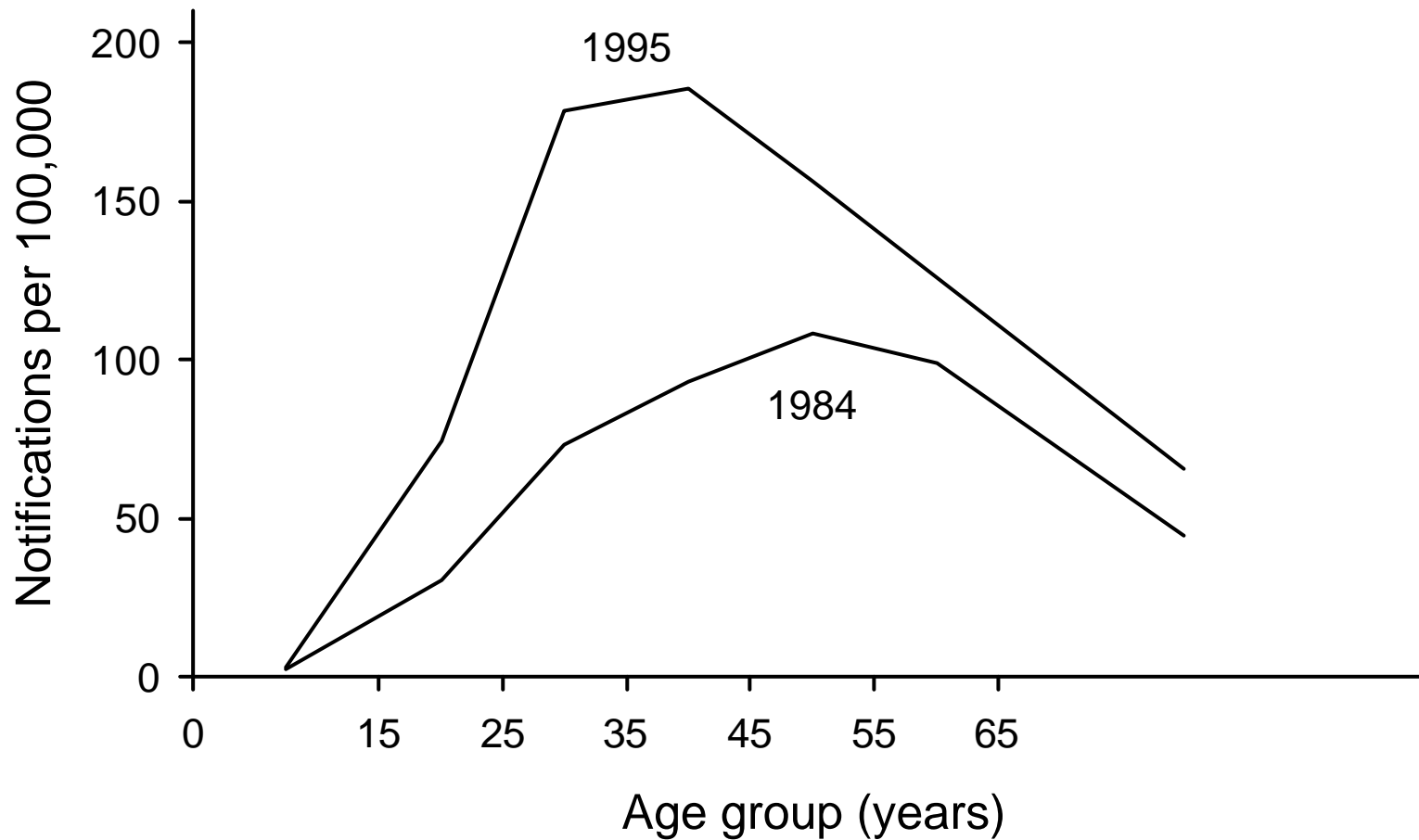

Change in HIV-Seroprevalence among Tuberculosis Patients in Tanzania, 1992 and 1995

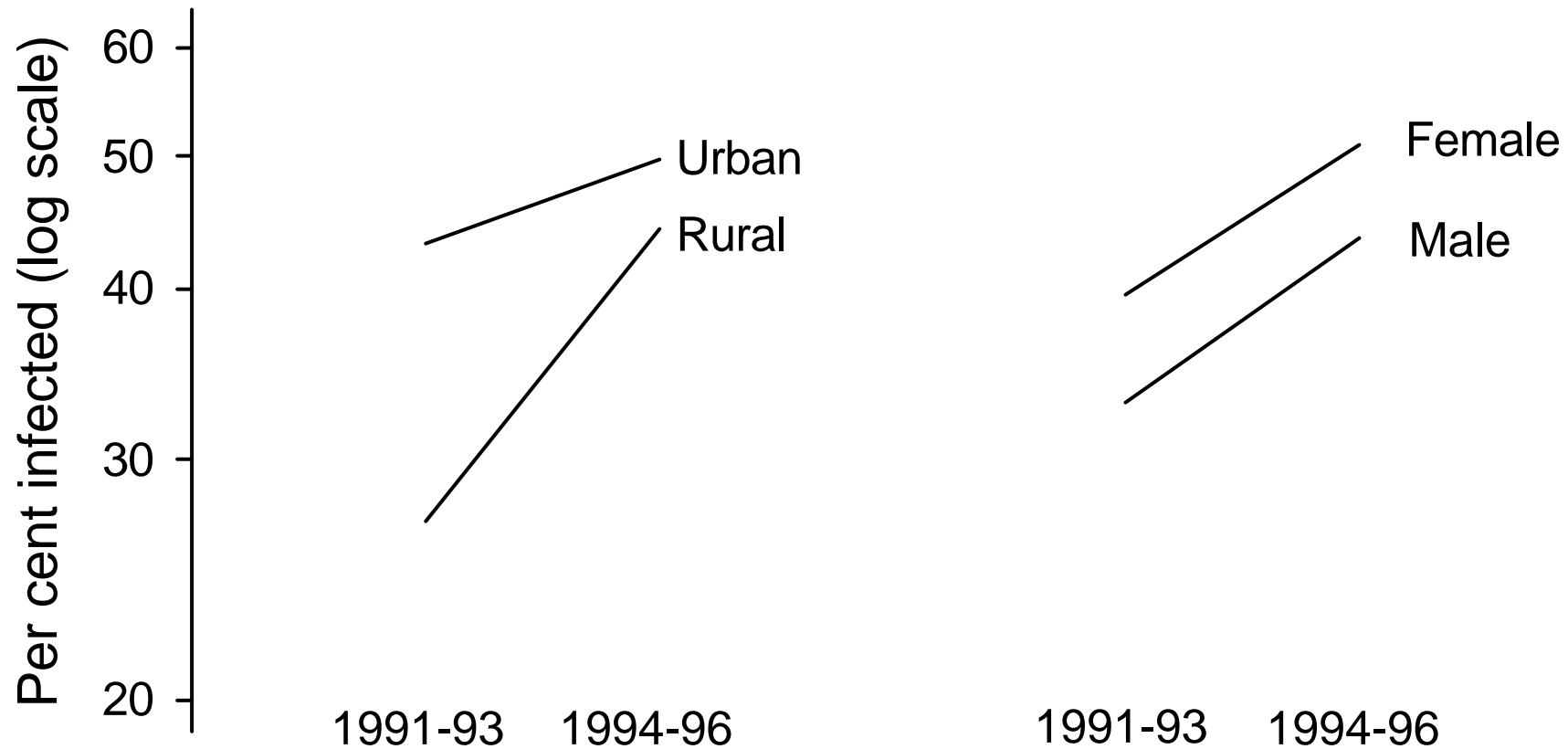

Tanzania NTLP / WHO / IUATLD. Unpublished data 1997

Impact of HIV Infection on Tuberculosis Notifications in Chiang Rai, Thailand, 1985 - 1994

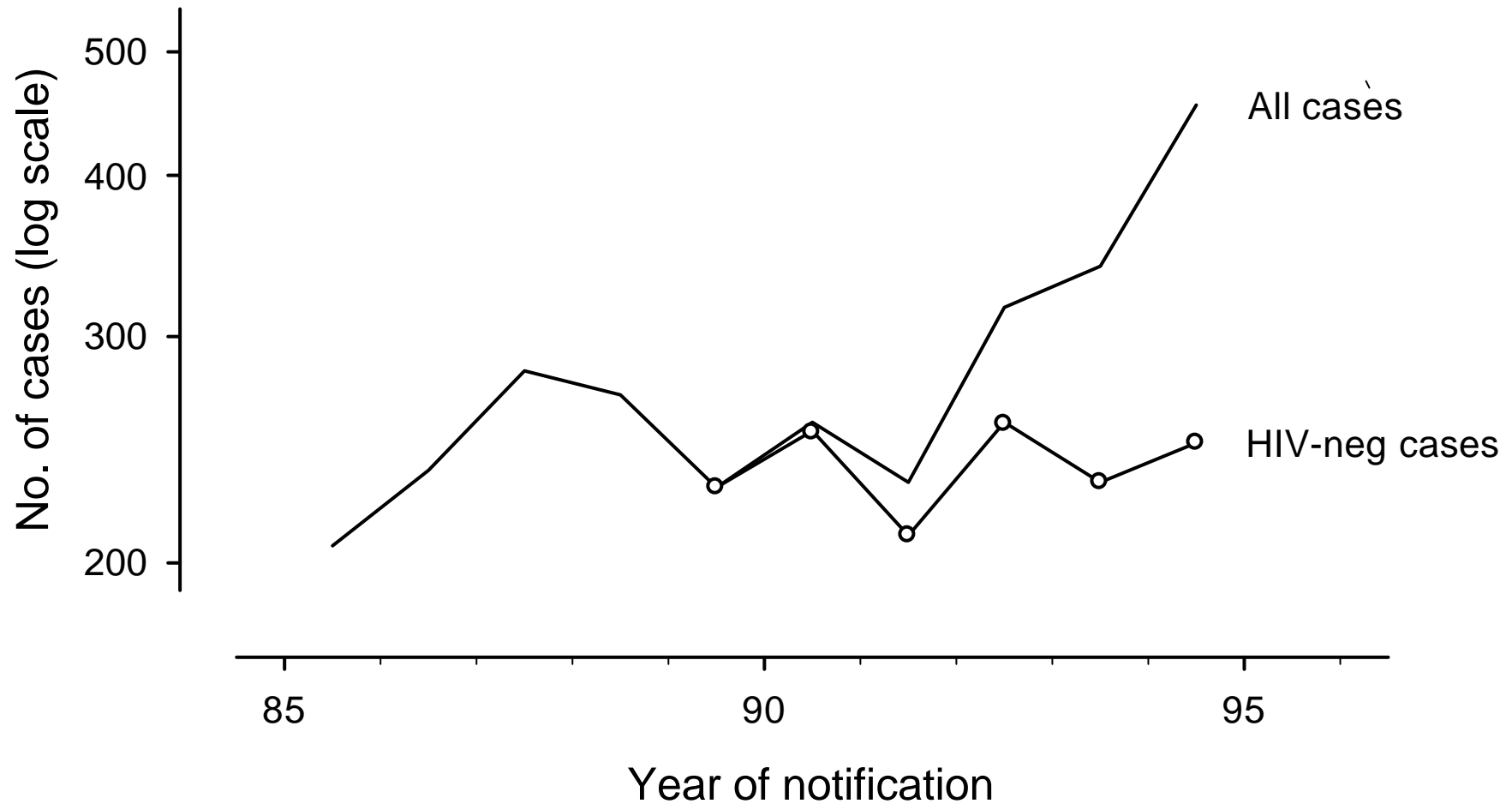

Proportion of Tuberculosis Cases Attributable to Primary Infection, Exogenous Reinfection, or Endogenous Reactivation, Among Males, by Age, Netherlands

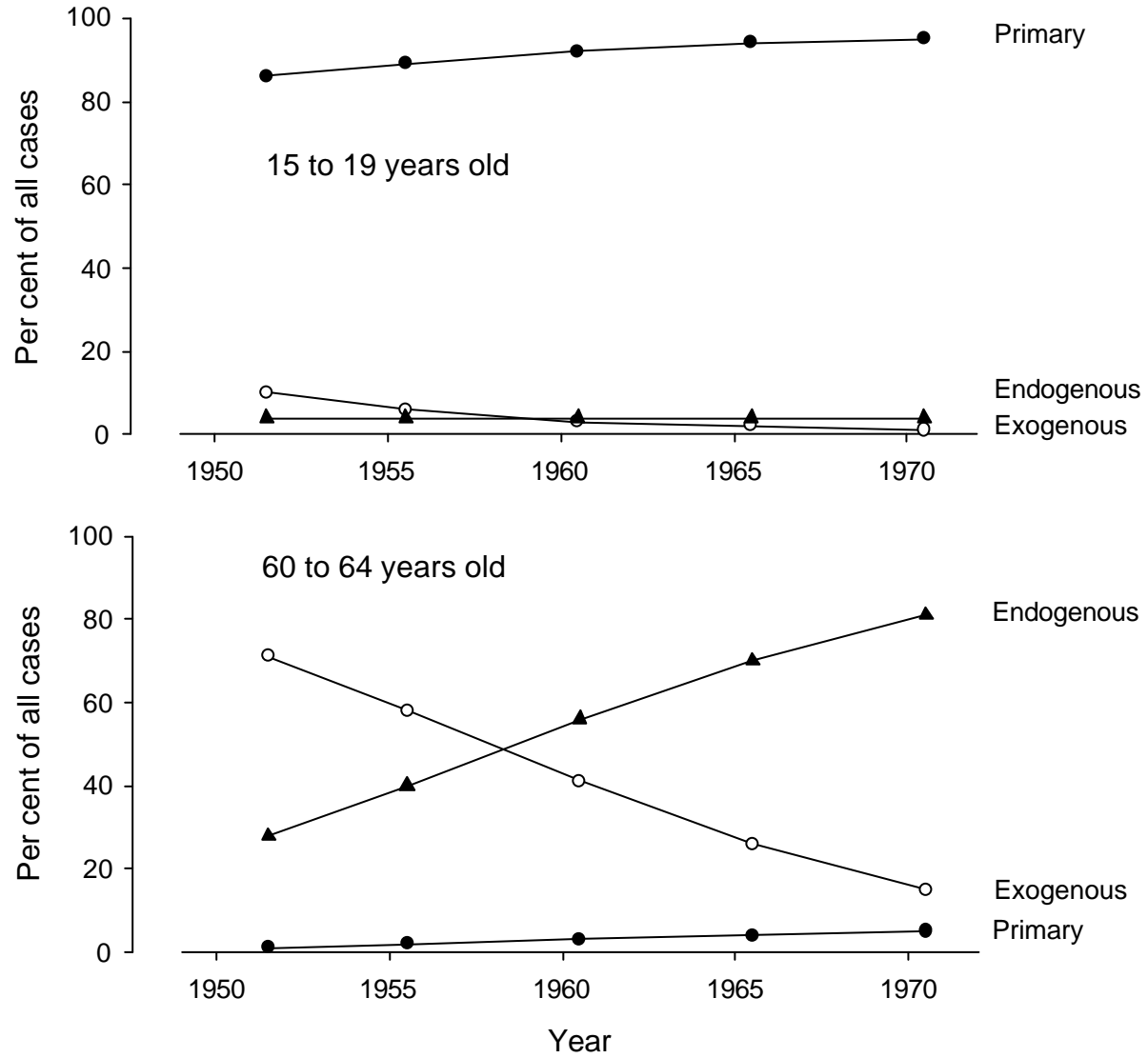

Projected Tuberculosis Incidence among Males in Finland, Years 2000 and 2010



WHO Forecasts for Tuberculosis Incidence, 1990 - 2005

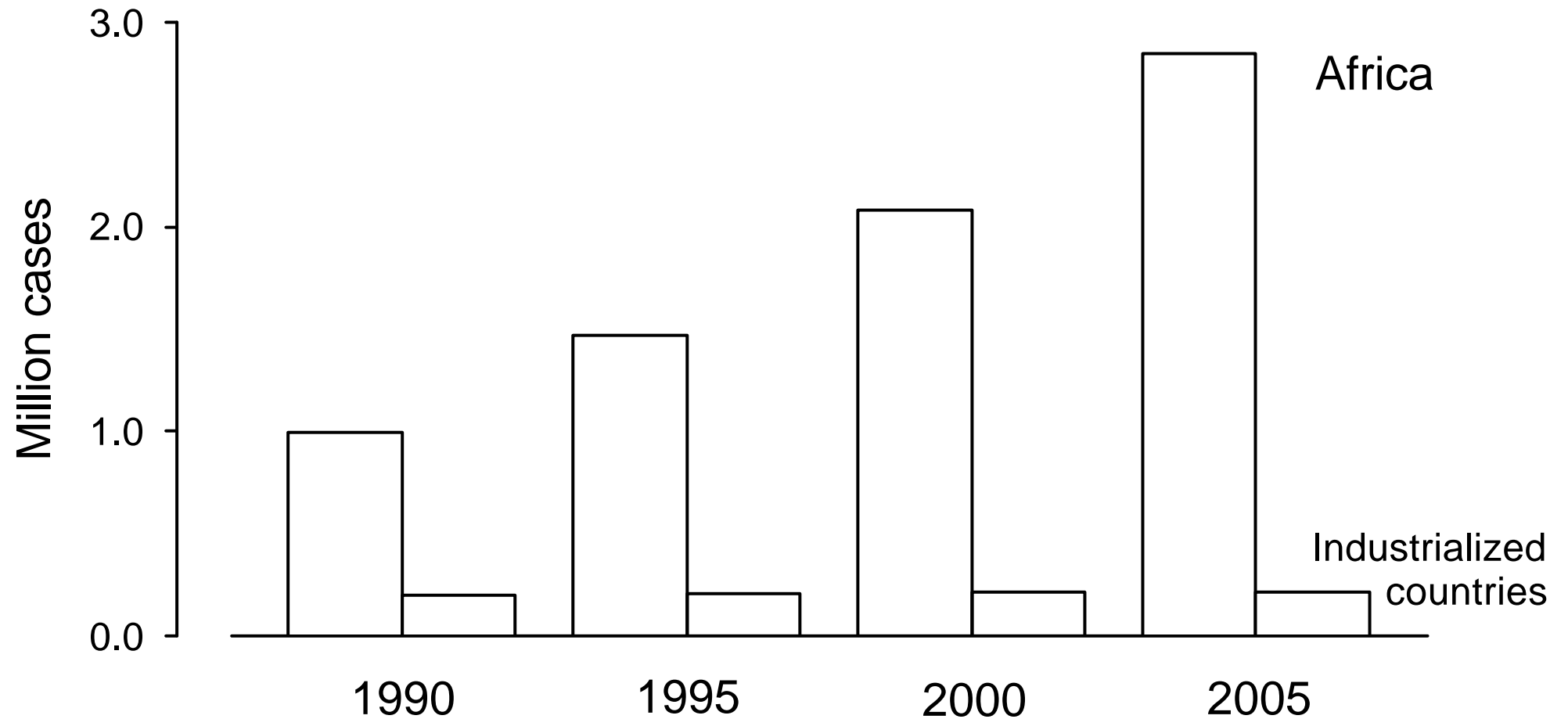

Dolin PJ, et al. WHO Document 1993;WHO/TB/93.173

Fate of Untreated Pulmonary Tuberculosis in Sanatorium Patients, Long-Term Follow-Up, Barmelweid, Switzerland

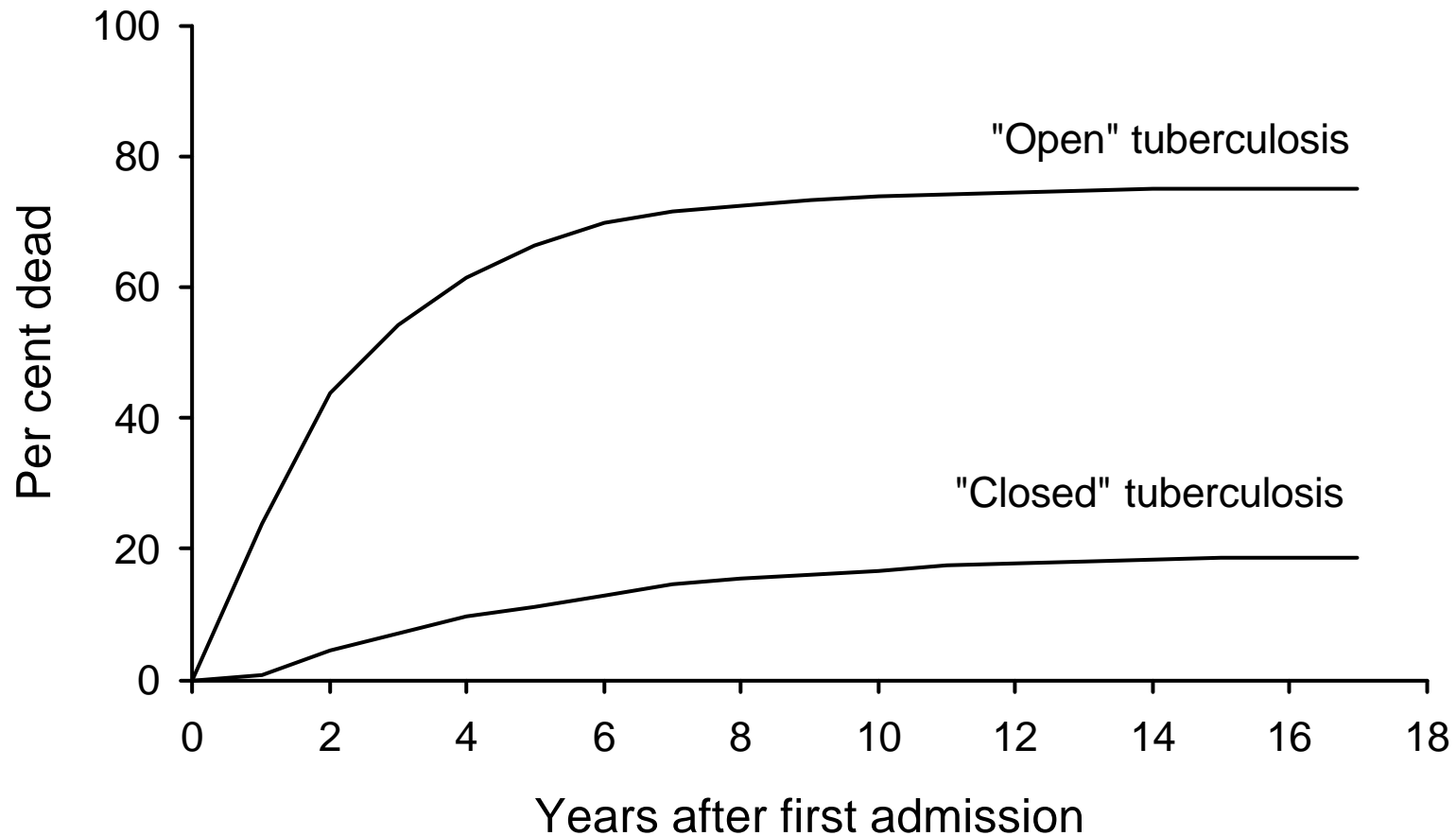

Krebs W. Beitr Klin Tbk 1930;74:345-79

Cumulative Case Fatality from Untreated Sputum Smear-Positive Pulmonary Tuberculosis

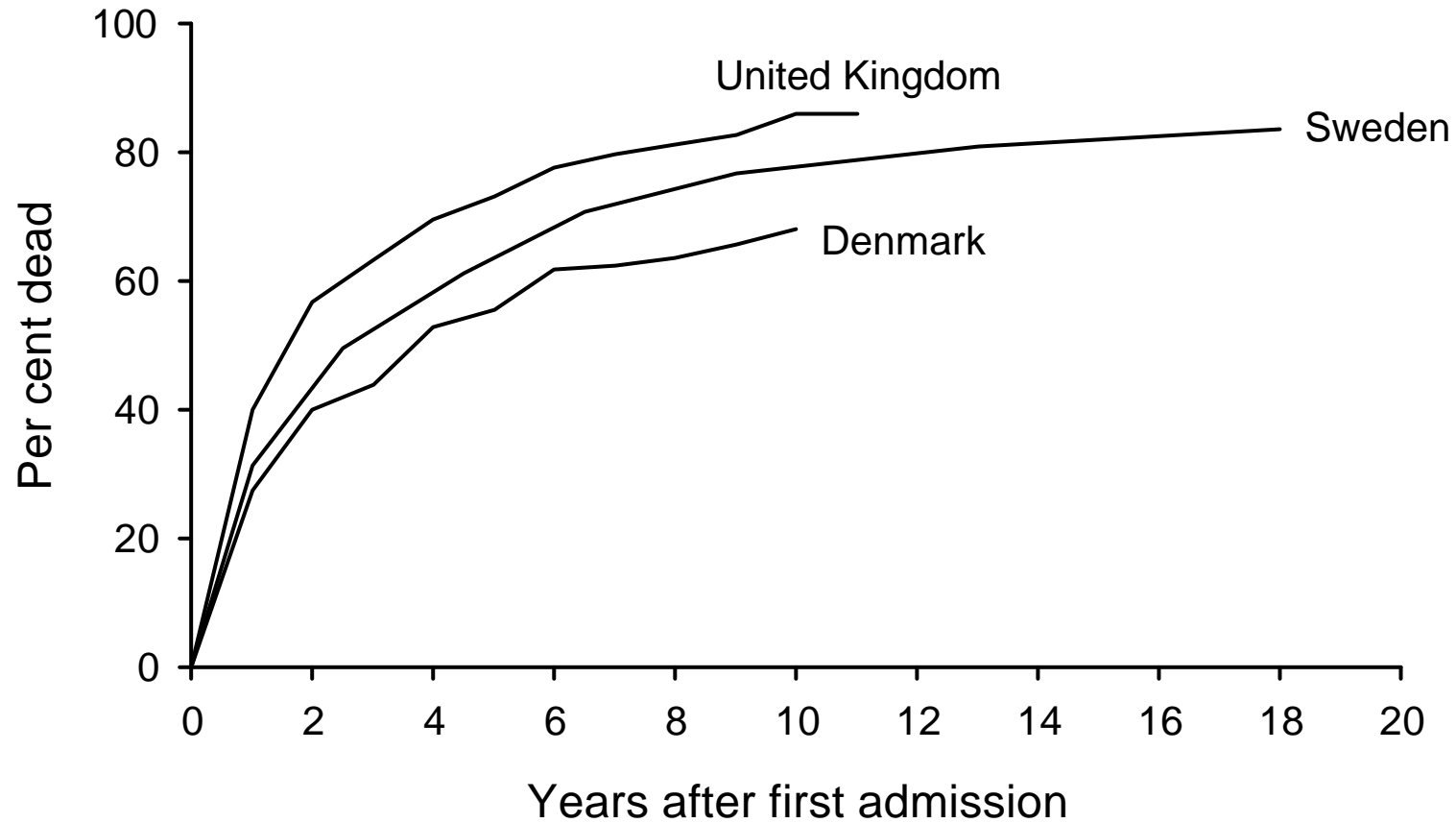

Thompson BC. Br Med J 1943;2:721

Berg G. Acta Tuberc Scand 1939;(suppl):1-207

Buhl K, et al. Bull World Health Organ 1967;37:907-25

Proportion of Tuberculosis Cases Diagnosed at Death, by Age, United States, 1985 - 1988

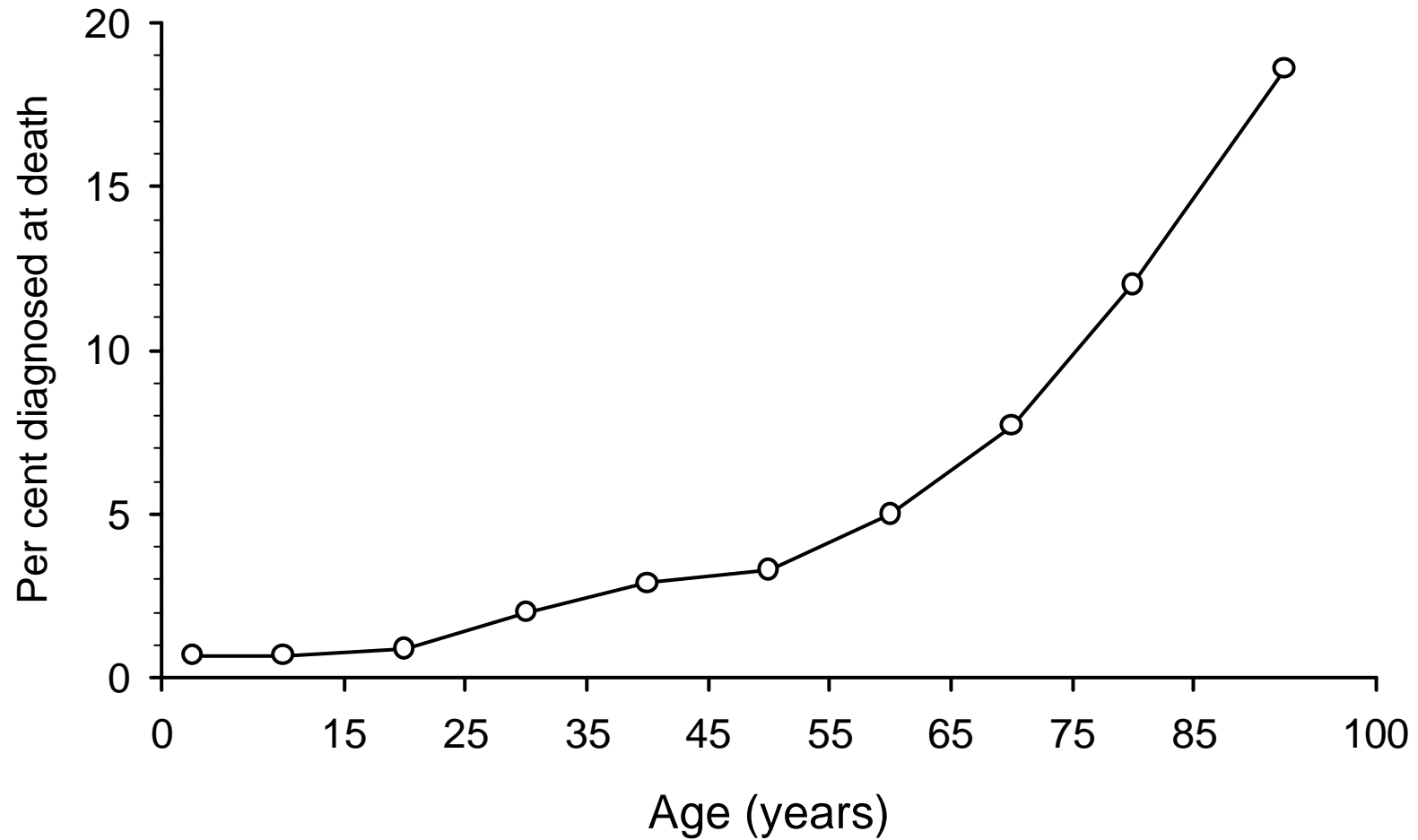

Rieder HL, et al. Chest 1991;100:678-81

Age-Specific Frequency of Death from Pulmonary Tuberculosis by Amount of Drugs Taken, North Arcot District, India, 1986 - 1988

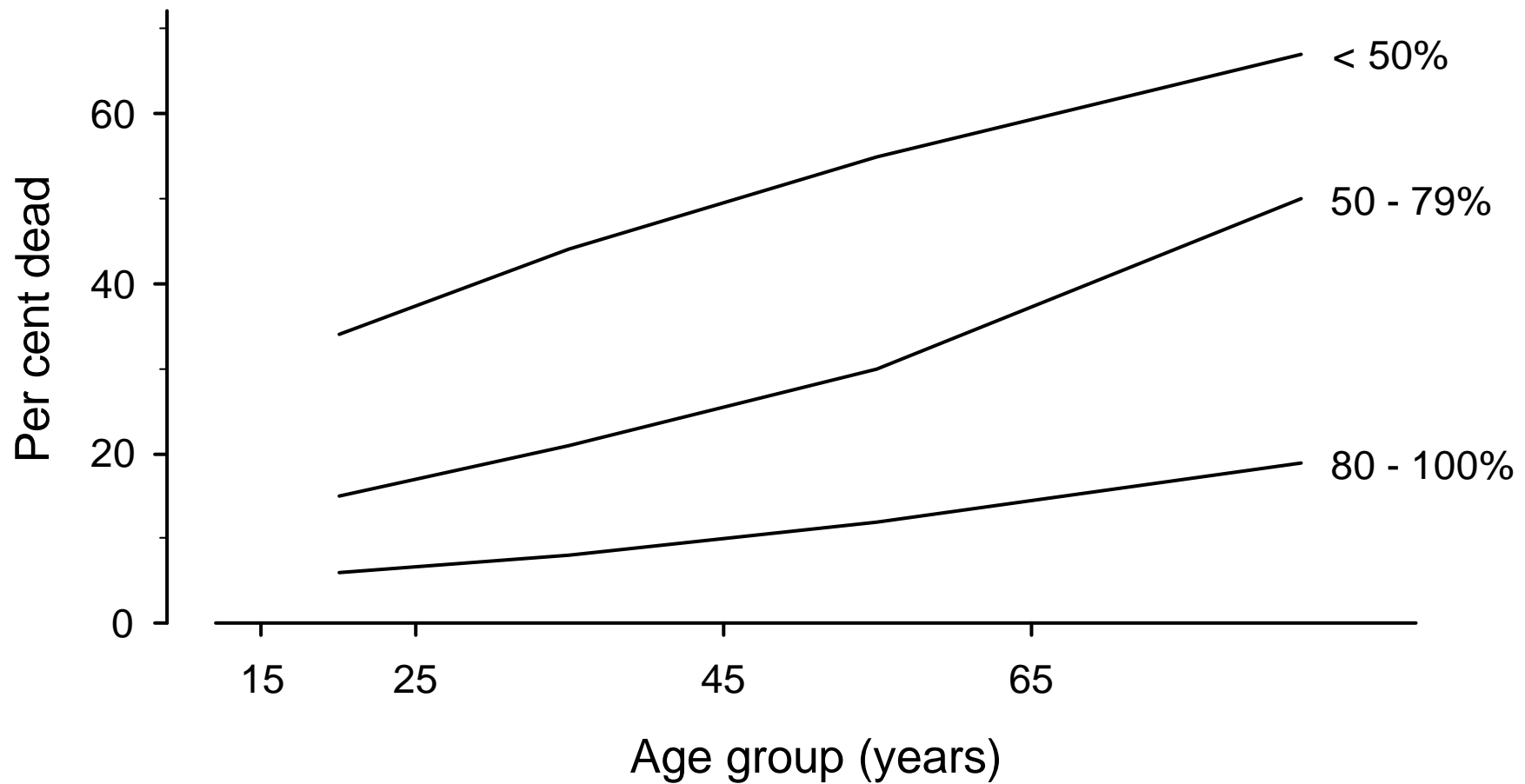

Datta M, et al. Tuber Lung Dis 1993;74:180-6

Tuberculosis Mortality in Three European Cities, Modeled From Available Data, 1750 - 1950

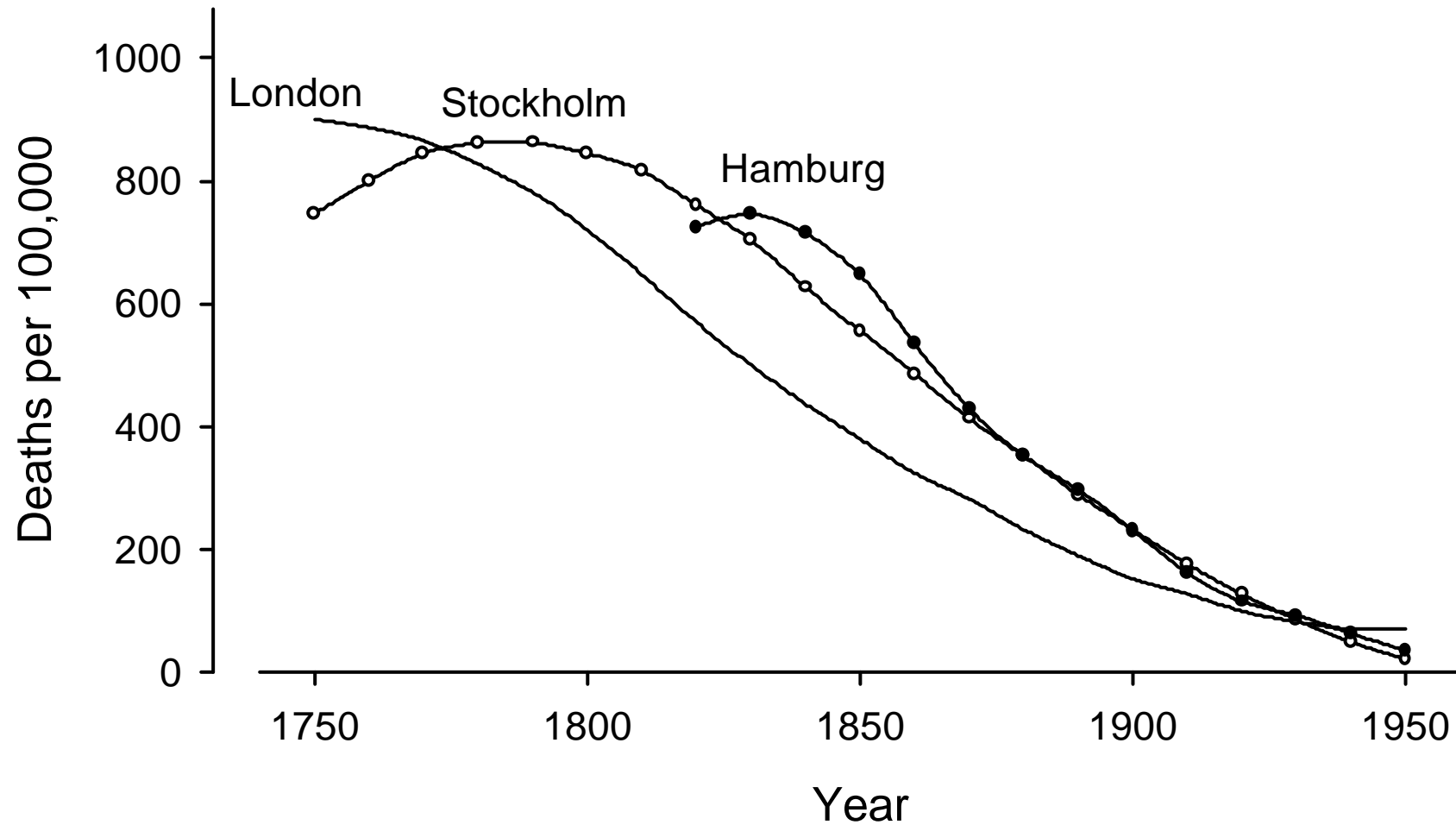

Grigg ERN. Am Rev Tuberc Pulm Dis 1958;78:151-72

Tuberculosis Mortality Rates in Germany, 1892 - 1940

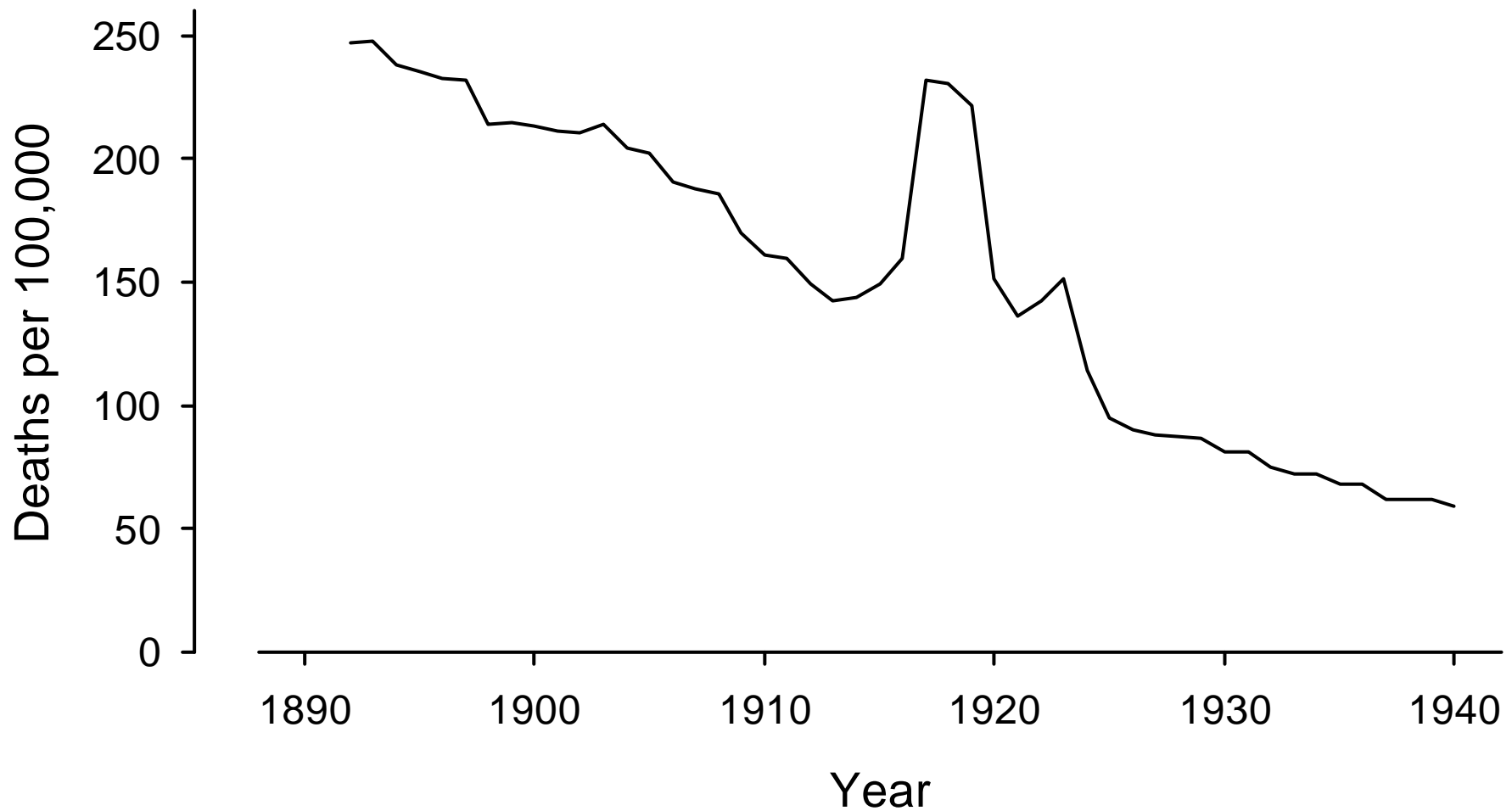

Redeker F. In: Handbuch der Tuberkulose (Hein J, et al, eds) 1958;1:473

Mortality from Respiratory Tuberculosis Among Males, Cross-Sectionally and by Birth Cohort, Switzerland

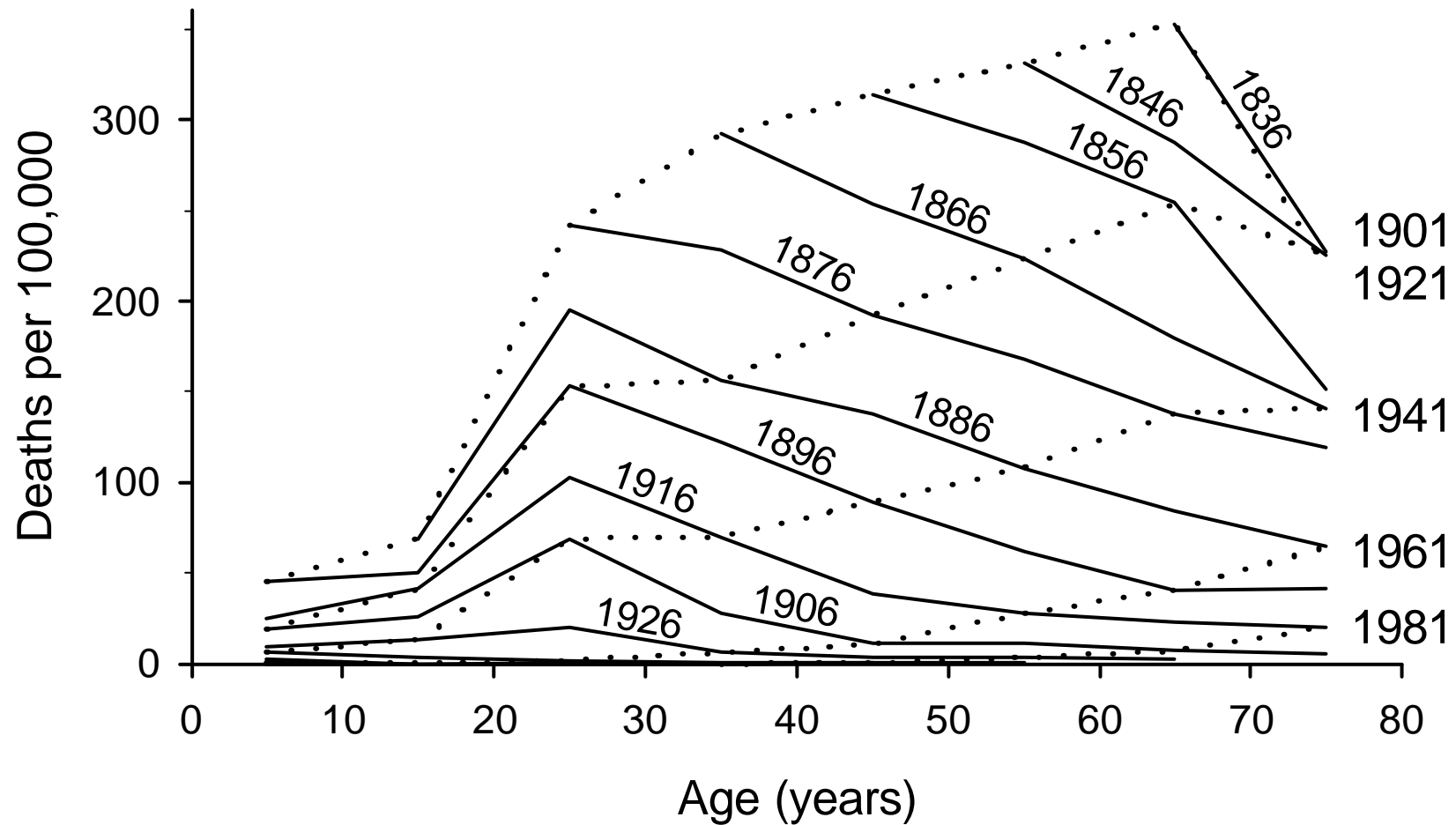

Mortality from Respiratory Tuberculosis Among Females, Cross-Sectionally and by Birth Cohort, Switzerland

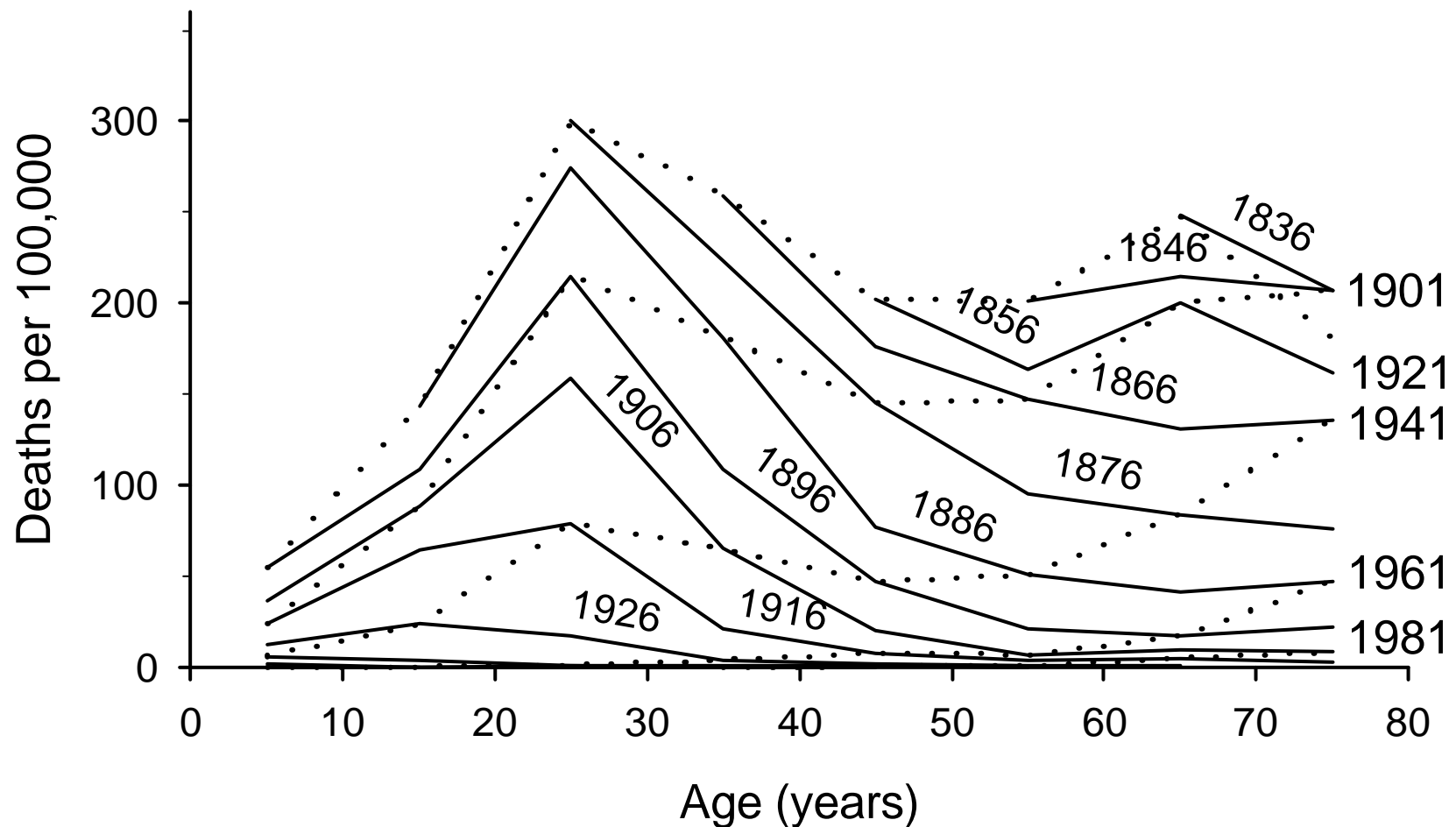

Rieder HL, et al. *Soz Präventivmed* 1998;43:162-6

Estimated Number of Tuberculosis Deaths by Region, for the Years 1990 - 2000

